

Premier®

1632 Automatic Letter Opener

PARTS LIST

REVISED 4/25/03

NO.	PART #	DESCRIPTION	QTY	No.	PART #	DESCRIPTION	QTY
1	M-O163201	IDLER PULLEY	1	23	M-S004003	6 X 3/8 PHIL PAN HD AB	4
2	M-O163202	ECCENTRIC PULLEY	1	24	M-S007008	10-32 HEX KEPS NUT	1
3	M-O163203	DRIVE PULLEY	1	25	M-S008005	3/16 SAE FLAT WASHER	1
4	M-O163204	CHASSIS MOTOR FRAME	1	26	M-S008087	#8 FLAT WASHER	2
5	W-O163205	CUTTER GUARD	1	27	M-S010002	5100-37 EXT. RET. RING	8
6	M-O163206	LOWER HOUSING	1	28	M-S010004	5133-25 EXT. "E" RING	2
7	M-O163207	UPPER HOUSING	1	29	M-S010005	5100-25 EXT. RET. RING	2
8	W-O163208	UPPER BLADE SPRING	1	30	M-S020003	1/4 X 5/8 X .19 BALL BRG	2
9	W-O163209	INTERLOCK ACTUATOR STP	1	31	M-S021051	1632 MOTOR 115 VAC	1
10	W-O163210	DECK PANEL	1	32	M-S022095	2GT 17T PULLEY 3/16 ID	1
11	W-O163212	CONVEYOR IDLER	2	33	M-S023042	#316 O'RING EPDM	2
12	W-A163213	UPPER BLADE ASSEMBLY	1	34	M-S025044	2GT X 300MM TIMING BELT	1
13	M-O163214	CONVEYOR BELT	2	35	M-S030001	RUBBER FOOT	4
14	W-O163215	CONVEYOR DRIVE SHAFT	1	36	M-S030020	3/4 SQ. X .35 RUBBER FT	1
15	M-O163216	HOLD BACK WHEEL	2	37	M-S033066	ROCKER SWITCH	1
16	W-O163217	HOLD BACK ARM	1	38	M-S033067	1632 MICRO SWITCH	1
17	M-O163219	HOLD BACK SPACER	1	39	M-S037088	2.5 RH FAN BLADE .187 ID	1
18	M-O163220	HOLD BACK SPRING	1	40	WRA045239	POWER CORD ASSY	1
19	W-A163222	LOWER BLADE ASSEMBLY	1	41	M-S045231	FUSE BLOCK 3AG SING	1
20	W-O163224	HOLD BACK SHAFT	1	42	M-S63601106	FUSE 5 AMP 110V	1
21	M-O163225	GEAR & PULLEY COMBO	1	43	M-S035035	HEYCO RELIEF SR4L-4	1
22	M-O163226	36T SPUR GEAR HUB	1				

Manufactured in the U.S.A. by:

Premier

Division of Martin Yale Industries, Inc.

251 Wedcor Avenue • Wabash, IN 46992

email: info@martinyale.com

web-site: www.martinyale.com

Phone (260) 563-0641 • Fax (260) 563-4575

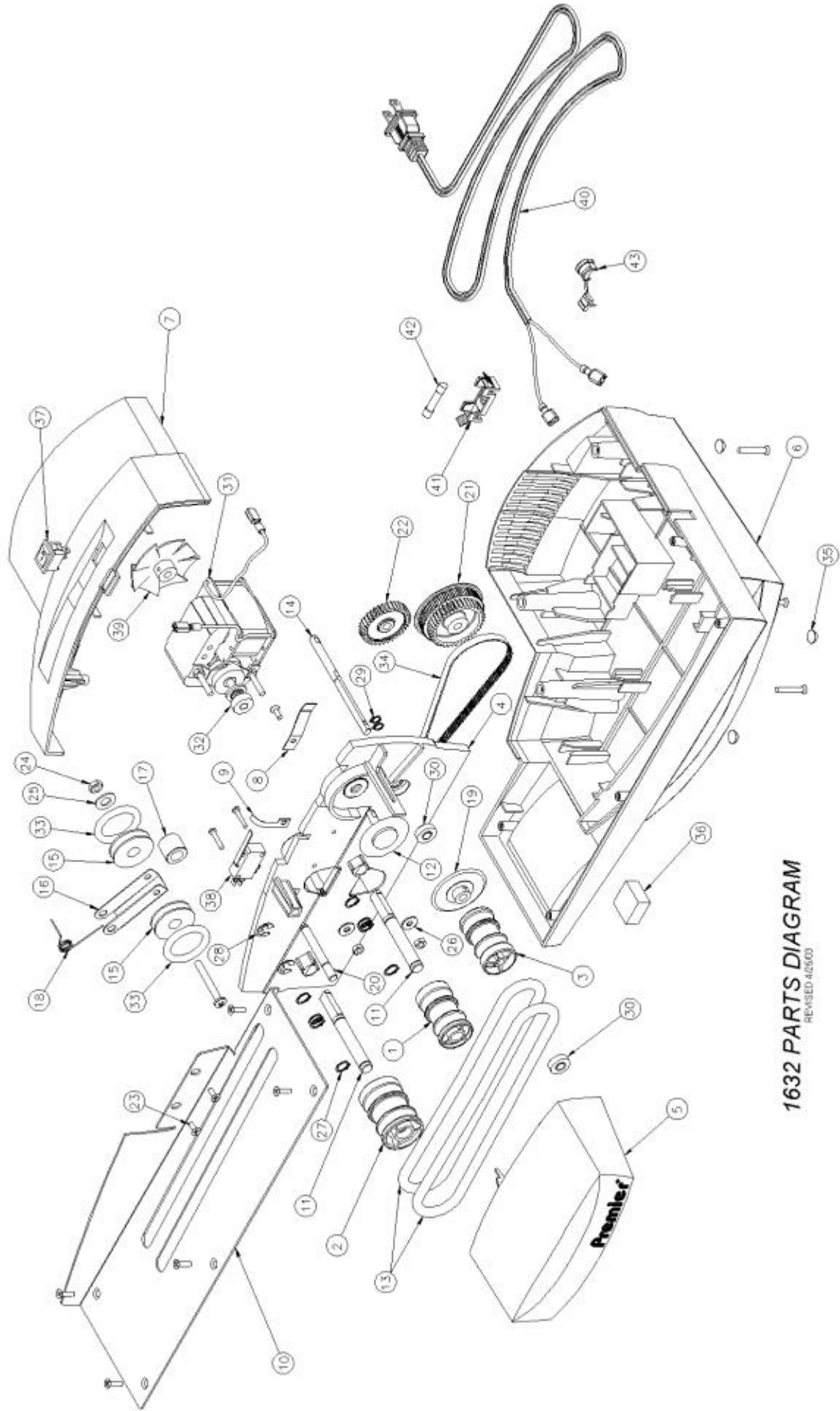

1632 PARTS DIAGRAM
REVISED 4/25/00