

## 1.0 Introduction

Thank you for selecting the Martin Yale Model J1824 Jiffy Giant Padding Press. We recommend that you familiarize yourself with the Jiffy Giant Padding Press by carefully reading these instructions. Thorough understanding of the information contained within these instructions will help to eliminate most operator associated errors and ensure years of trouble-free performance.

## 2.0 Assembly

- 2.1 Locate all loose parts in the package (refer to parts list and diagram).
- 2.2 Mount the door handle using two sets of the screws and nuts supplied.
- 2.3 Bolt the sides to the top and bottom with the smooth sides of the parts facing inside. Tighten the screws.
- 2.4 Mount the paper clamps to the sides with the knobs and washers as shown in the diagram. The rubber tips on the thumbscrews face downward and the nylon washers go between the knobs and side frames.
- 2.5 Install the Elevation Bar by inserting leg ends (first one side, then spread to fit other side) into the holes provided at the bottom ends of the sides, (second hole).

## 3.0 Operation

**NOTE:** For best results, all material should be jogged before padding.  
*Martin Yale Model 400 or 4200 Jogger is recommended.*

- 3.1 Rotate the Elevation Bar to tilt the press forward. Drop the door in place; the bottom edge into the slot on the Base Plate and the top edge over the Top Plate.
- 3.2 Square the paper into the press against the door. Place the pressure plate on the top of the paper stack against the door.
- 3.3 Lower the Paper clamps to the pressure plate and tighten the hand knobs. Use the thumbscrews to apply additional pressure. **Do not use tools such as wrenches or pliers!**
- 3.4 Remove the door and apply padding compound to the facing edge of the paper stack. When dry, release the clamps to remove pad.
- 3.5 **For Carbonless Paper**  
The pressure plate is constructed so that it can be set on the edge of the paper for little penetration or moved away from the edge so that the carbonless padding compound can penetrate further into the sheet. If you are doing snap-outs in carbonless forms, you can move the pressure plate in about 1/4 " and the padding compound will penetrate just as well as if you used a tipping machine.

## 4.0 Maintenance

Clean unit after use with warm, soapy water. Do not use the same brush for regular and carbonless padding compounds. A paper liner can be used to minimize clean up.



251 Wedcor Drive  
Wabash, IN 46992

Phone (260) 563-0641

Fax # (260) 563-4575

[www.martinyale.com](http://www.martinyale.com)

M-S027083

Revised 10/00

**Parts List  
Model J1824**

**Parts Diagram**

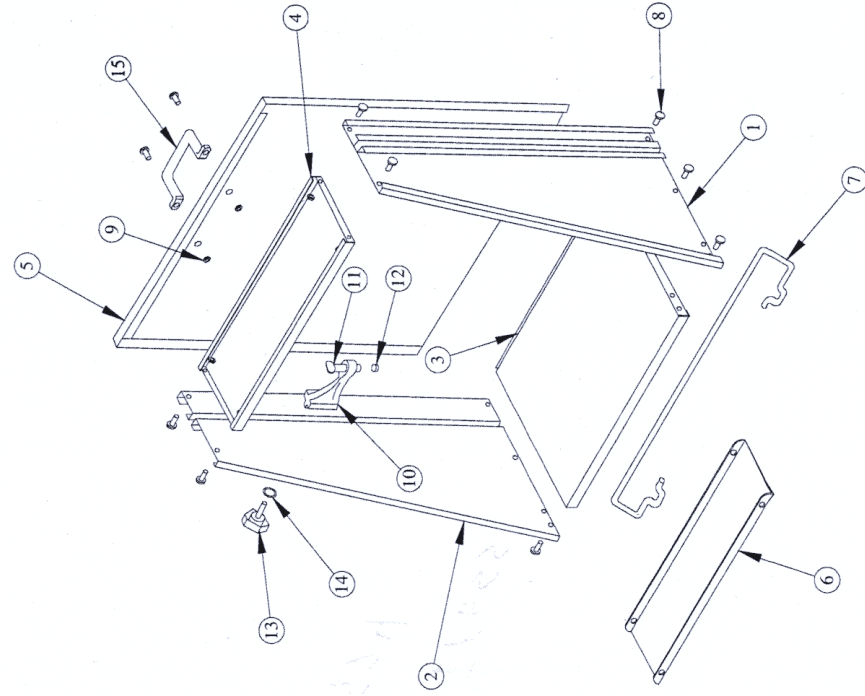

Item #	Part #	Qty.	Description
1	W-O182407	1	Right Side Panel
2	W-O182406	1	Left Side Panel
3	W-O182401	1	Base Plate
4	W-O182404	1	Top Plate
5	W-O182402	1	Door
6	W-O181103	1	Pressure Plate
7	M-O182412	1	Elevation Bar
8	M-S001022	12	10-32x3/8 Screw
9	M-S007008	12	10-32 Nut
10	M-O181105	2	Padding Press Clamps
11	M-S005006	2	1/4-20x2 Thumb Screw
12	M-S030016	2	1/4 Rubber Tips
13	M-S032069	2	Padding Press Knobs
14	M-S008011	2	1/4 x 1/2 Nylon Washer
15	M-S037380	1	Door Handle
Not Shown	M-S027083	1	Instruction Sheet