

CR-20 Cornerounder[®]

Operating Instructions



Before operating this equipment, please read these instructions completely and keep these operating instructions for future reference.

Date of Purchase: _____

Dealer: _____

Address: _____

Telephone Number: _____

Operating Instructions

- Insert the Cutting Unit into the CR-20 base by lifting up on the Handle Assembly as shown below. Make sure that the Handle Pad comes down correctly over the Cutting Unit.
- Place the product you are cutting onto the Plastic Top Plate and push it into the corner aligning it with the Table Guides. Press down firmly to prevent the product from sliding out of the corner.
- Push down on the Handle until the blade on the Cutting Unit cuts through the stack of product.
- Remove chips as needed by sliding open the Chip Door and removing all the chips.

Note: This machine was designed to cut up to a 1/2" stack of paper. It will also cut many other materials such as cardboard, celluloid, leather, wood and even light soft metals. With heavier materials, however, best results may be obtained if only one or a few pieces are cut at a time.

Maintenance

- Your CR-20 should be relatively maintenance free. It is recommended that you occasionally apply a few drops of light oil on the lever hinge screws to maintain proper movement.
- The knives on the Cutting Units are hardened steel, finely ground, and due to their shear action will give long and satisfactory service. When they do become dull or require attention, we suggest returning the Cutting Unit for factory service, which includes sharpening and replacement of worn parts.

Parts Diagram

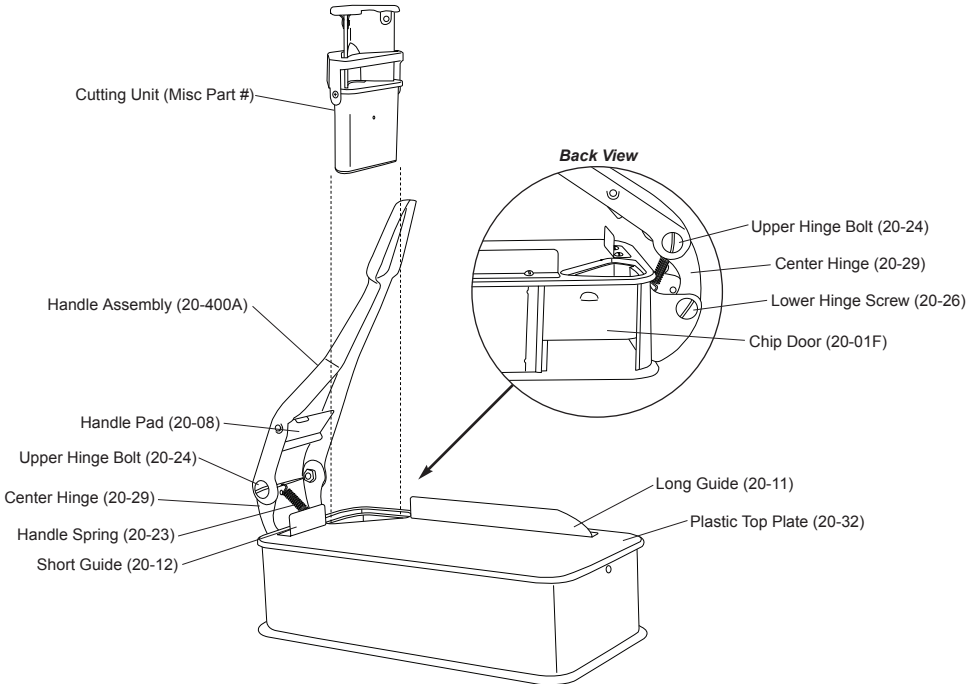

Lassco *Wizer*

485 Hague Street, Rochester, NY 14606 U.S.A.
Tel: 585-436-1934 Fax: 585-464-8665
www.lasscowizer.com info@lasscowizer.com