

Mod.4810-95 B

01.08.2009

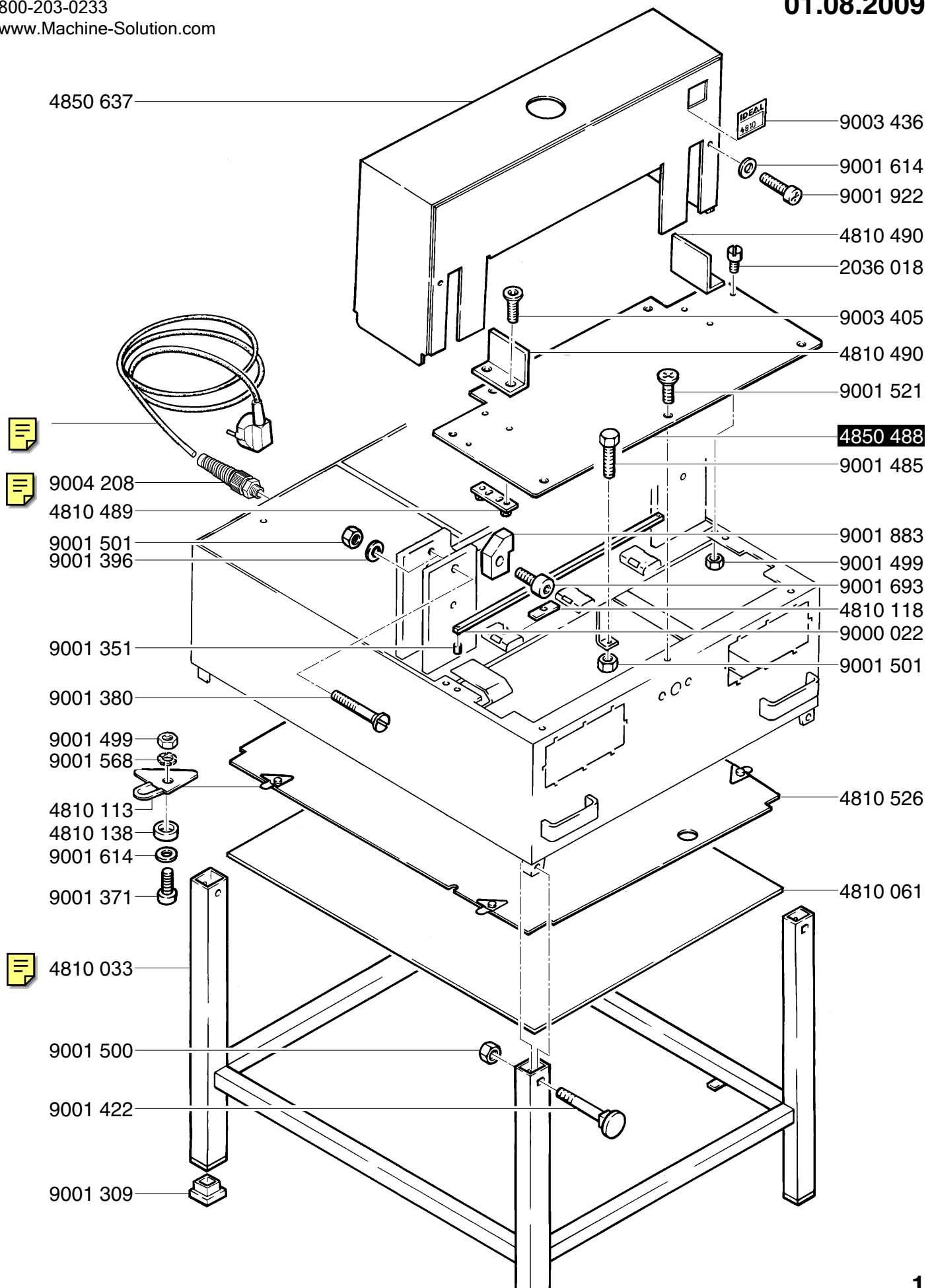

Mod.4810-95 B

01.08.2009

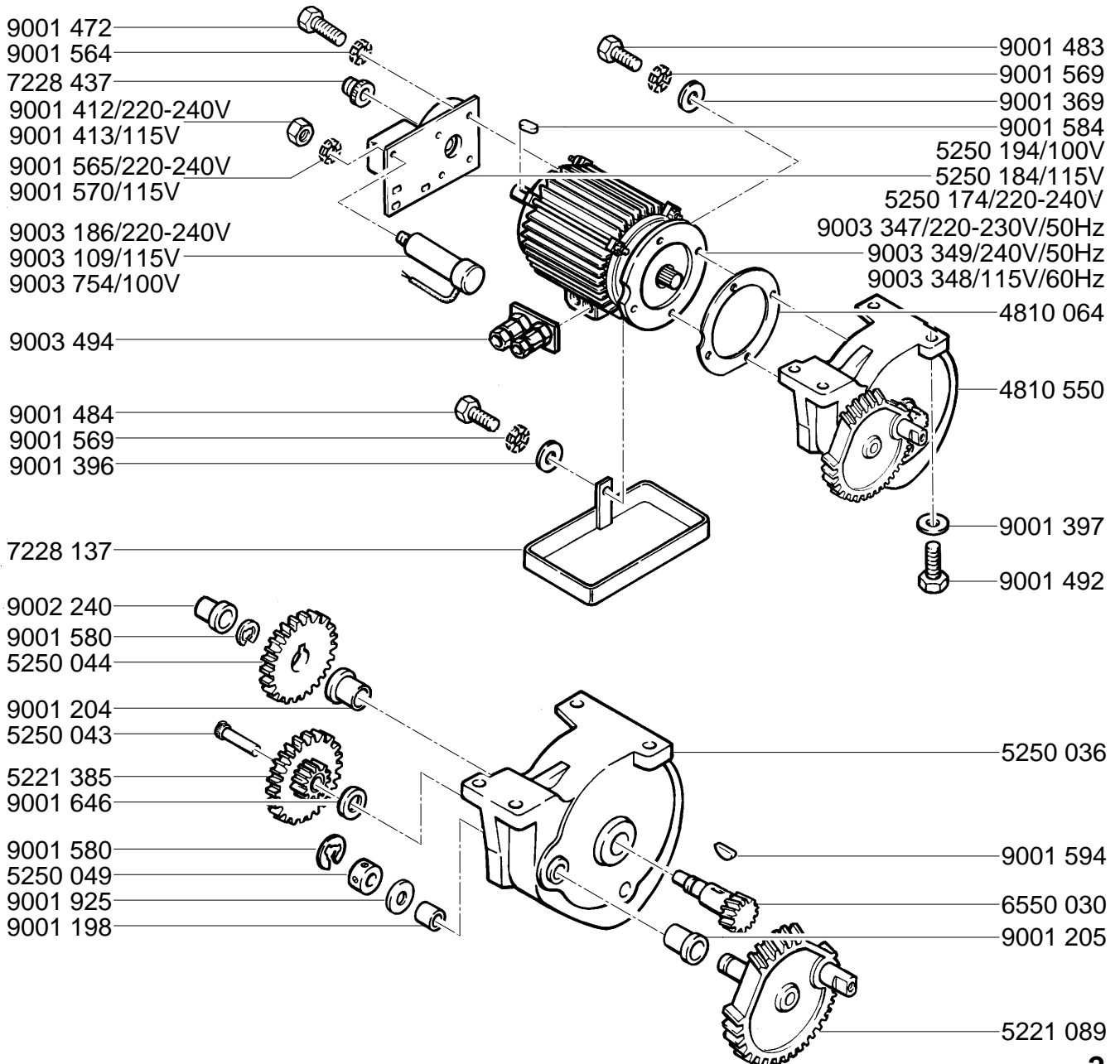
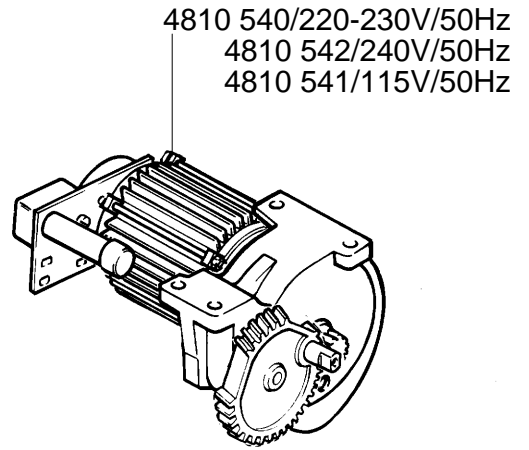
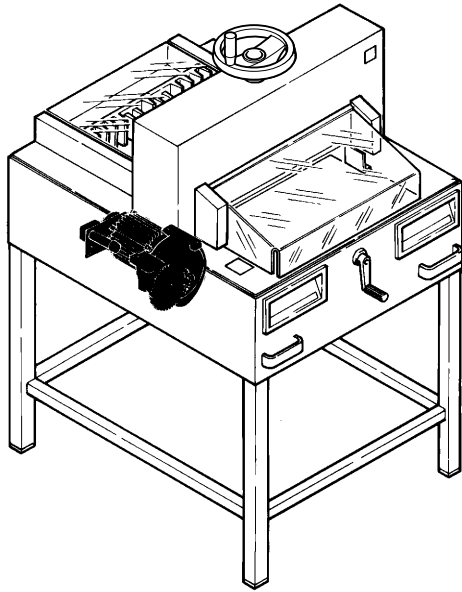

Mod.4810-95 B

01.08.2009

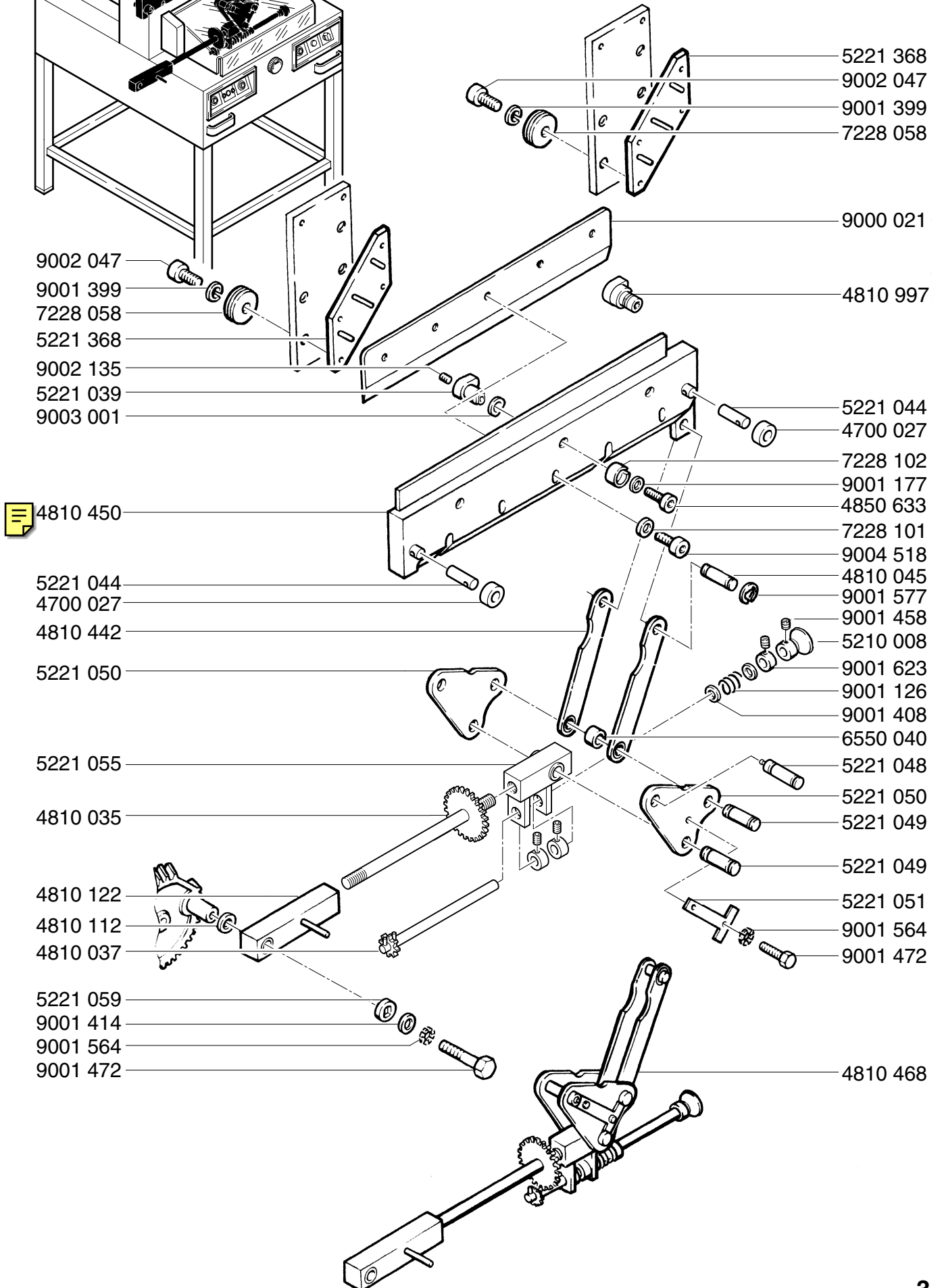
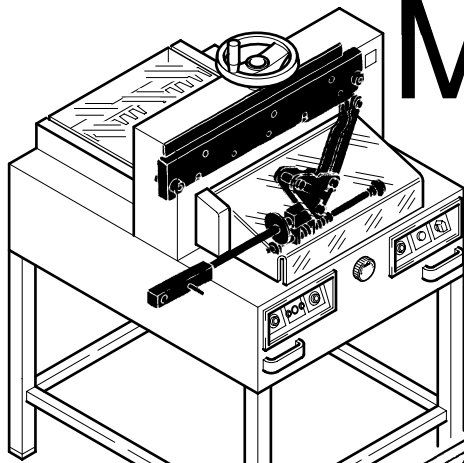

Mod.4810-95 B

01.08.2009

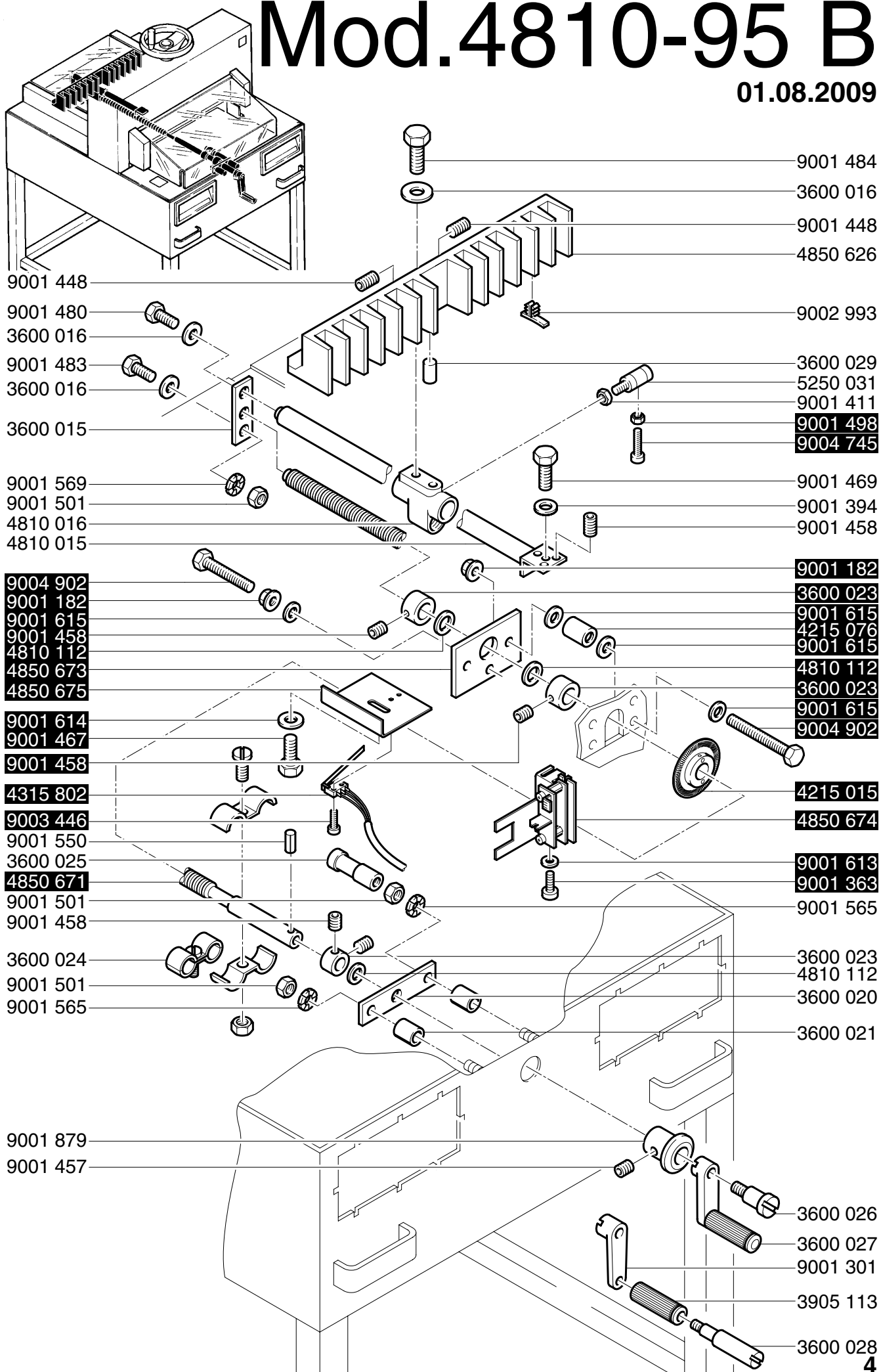

- 9001 448
- 9001 480
- 3600 016
- 9001 483
- 3600 016
- 3600 015
- 9001 569
- 9001 501
- 4810 016
- 4810 015
- 9004 902
- 9001 182
- 9001 615
- 9001 458
- 4810 112
- 4850 673
- 4850 675
- 9001 614
- 9001 467
- 9001 458
- 4315 802
- 9003 446
- 9001 550
- 3600 025
- 4850 671
- 9001 501
- 9001 458
- 3600 024
- 9001 501
- 9001 565
- 9001 879
- 9001 457

- 9001 484
- 3600 016
- 9001 448
- 4850 626
- 9002 993
- 3600 029
- 5250 031
- 9001 411
- 9001 498
- 9004 745
- 9001 469
- 9001 394
- 9001 458
- 9001 182
- 3600 023
- 9001 615
- 4215 076
- 9001 615
- 4810 112
- 3600 023
- 9001 615
- 9004 902
- 4215 015
- 4850 674
- 9001 613
- 9001 363
- 9001 565
- 3600 023
- 4810 112
- 3600 020
- 3600 021
- 3600 026
- 3600 027
- 9001 301
- 3905 113
- 3600 028

Mod.4810-95 B

01.08.2009

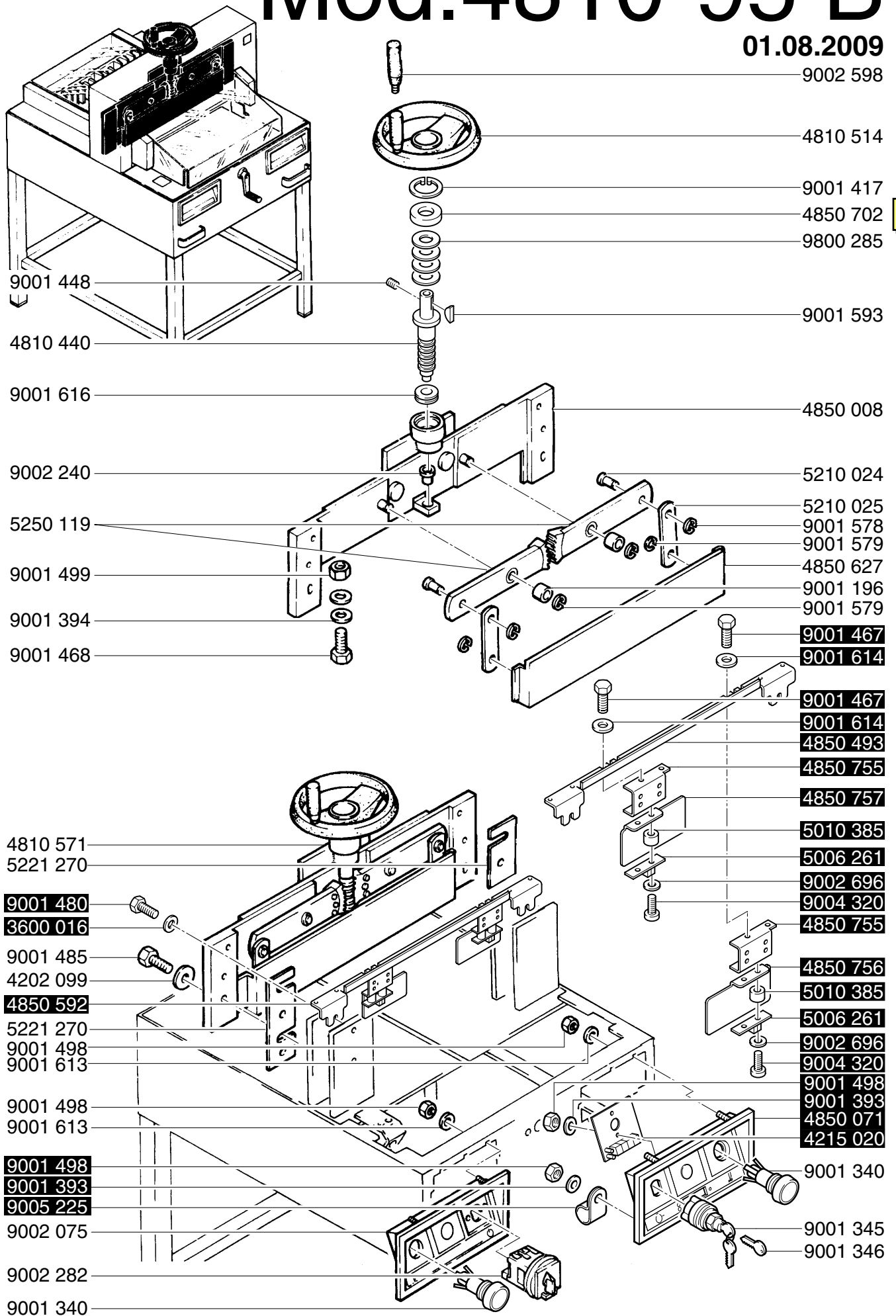

Mod.4810-95 B

01.08.2009

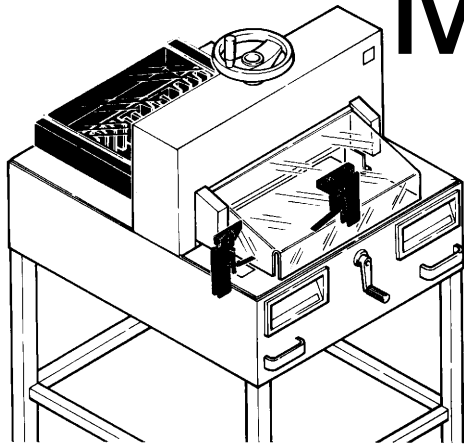

9001 913

4810 565

4850 625

4850 614

7228 468

4850 623

9001 614

9001 908

5250 065

9001 497

9001 562

5250 068

4810 496

9001 329

4810 527

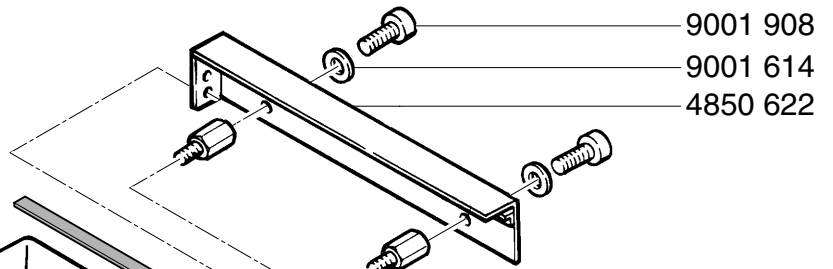

9001 908

9001 614

4850 622

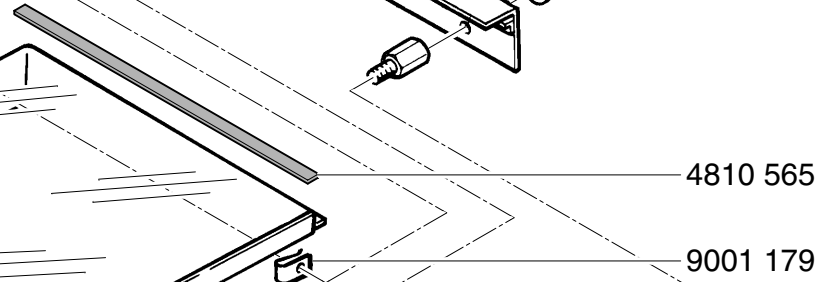

4810 565

9001 179

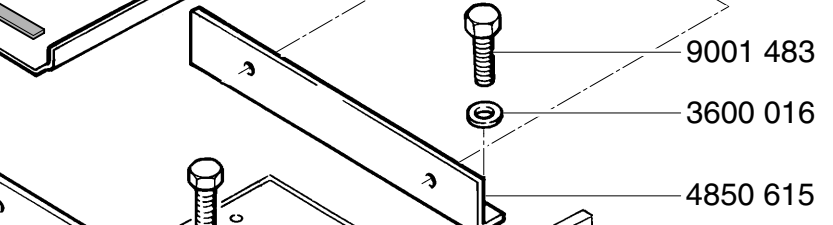

9001 483

3600 016

4850 615

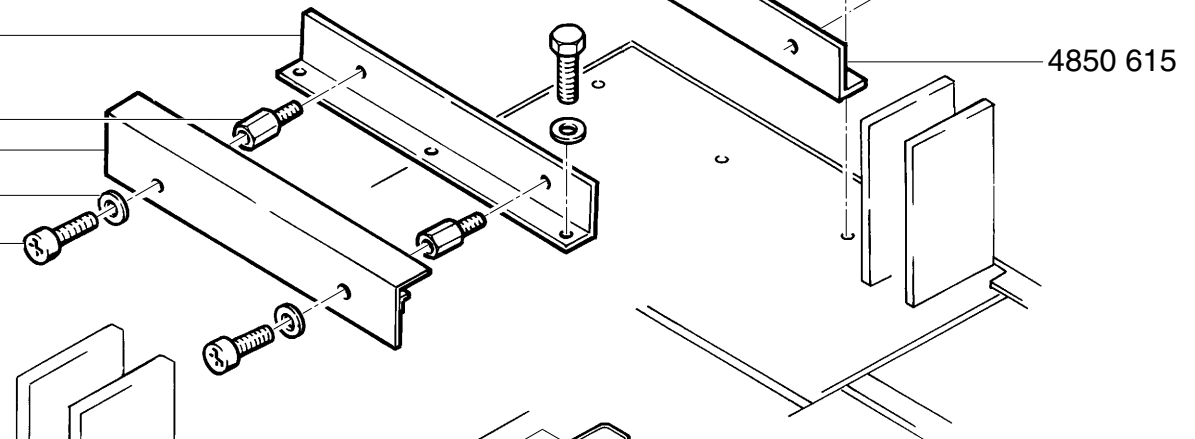

9001 216

9001 472

5250 064

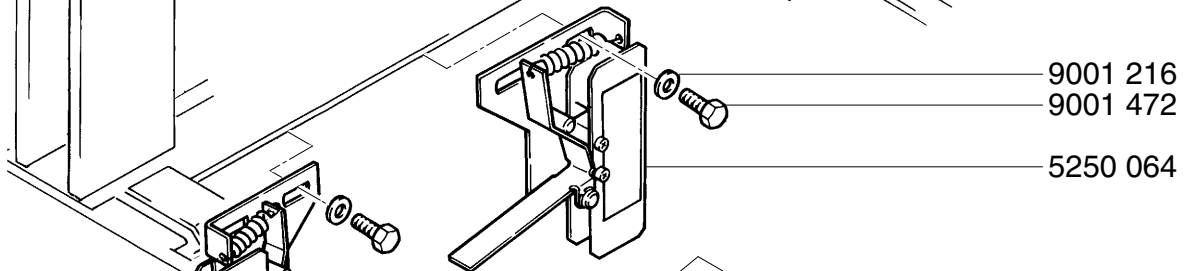

5250 067

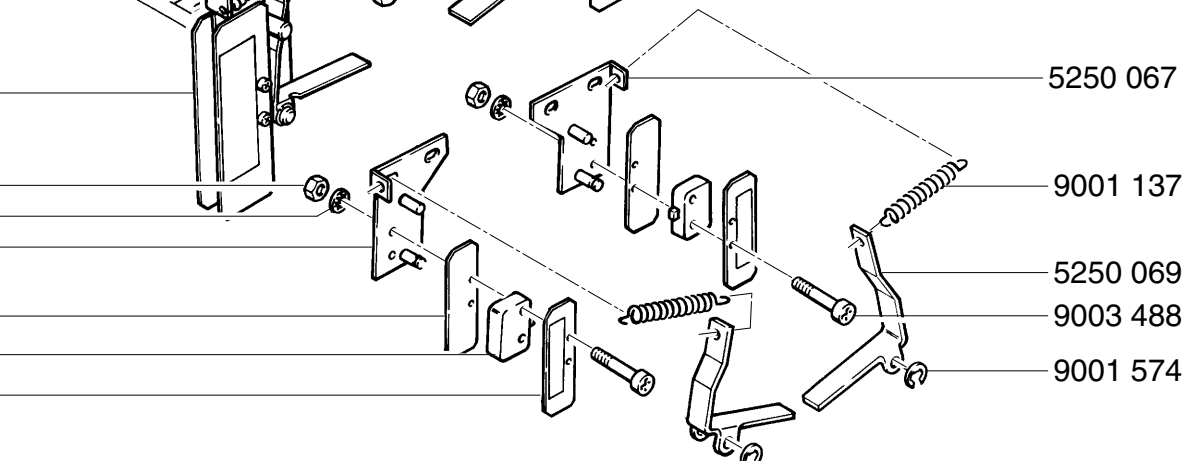

9001 137

5250 069

9003 488

9001 574

Mod.4810-95 B

01.08.2009

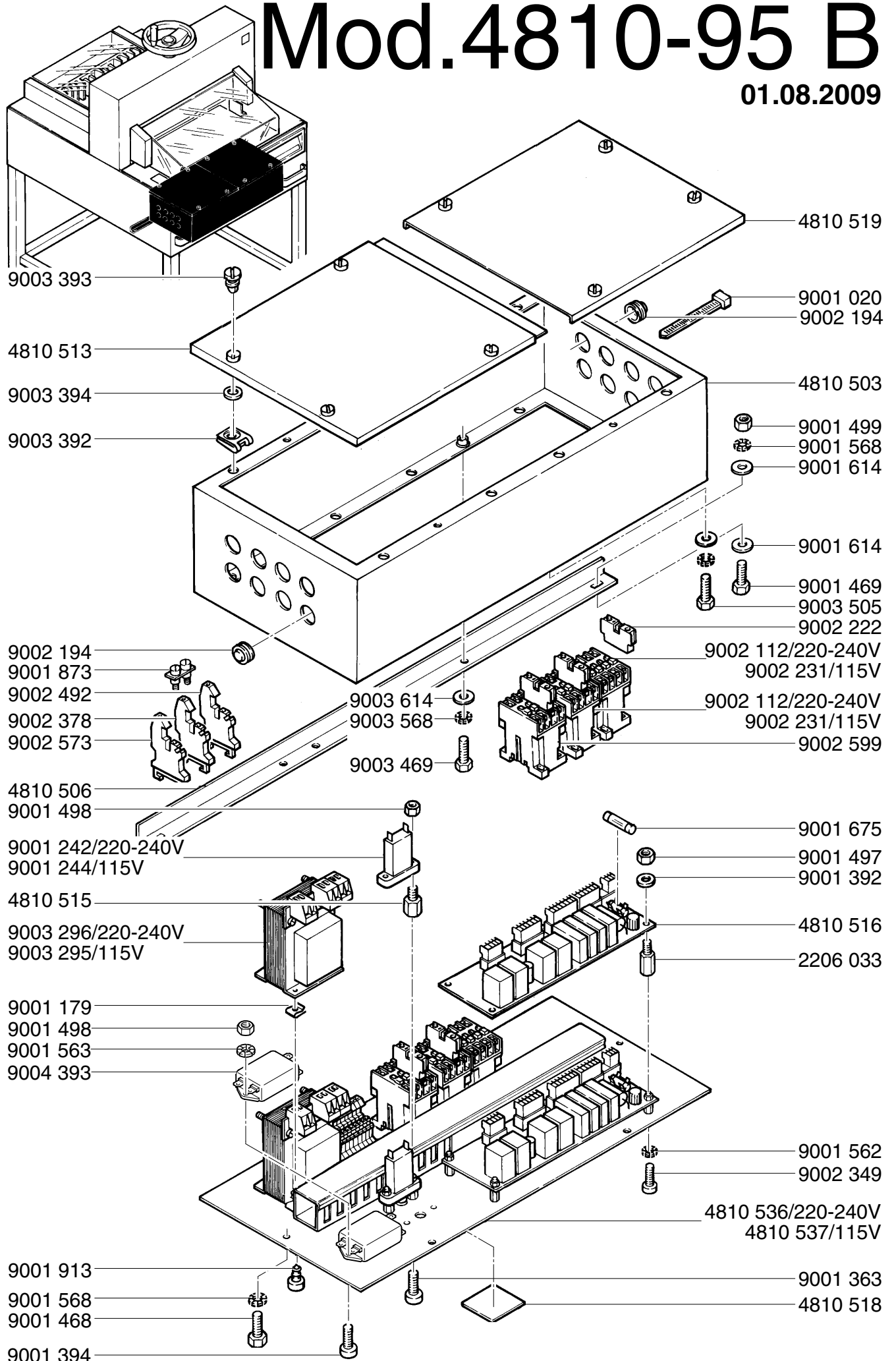

Mod.4810-95 B

01.08.2009

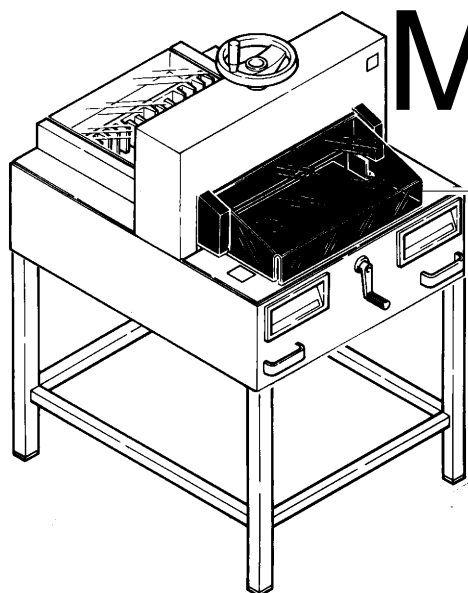

4810 499

9001 363
9001 563
9003 473

9003 094
9001 337
9001 563
4810 454
9001 563
9002 130

4810 459
9001 574

9003 510

9001 574
4810 455

9003 510
9003 354
9003 094

9001 563
4810 458
9001 563
9002 130
4810 482

9001 534
9001 556
9003 429
9001 556
4810 480
9001 646
9001 498
9001 646

4810 451

9001 869
9001 216
9001 564
9001 473

4810 570

4810 470

4810 449
9001 646
4810 470
9003 429
9001 556
9001 556
9001 534

9001 574

9003 434

9001 574

9003 094

9001 020

4810 487

9001 363

9001 646
4810 472
9001 869

9001 216
9001 564
9001 473

4810 475

9001 498

9002 130

9001 563
4810 458

9001 574

4810 457

9001 563

9003 354

9003 510

9003 473

9001 563

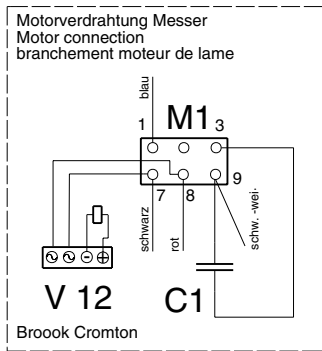
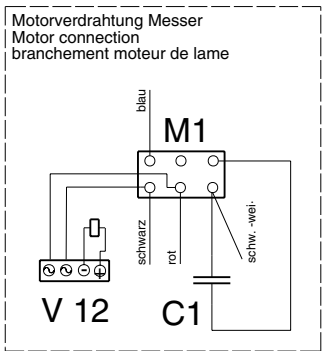
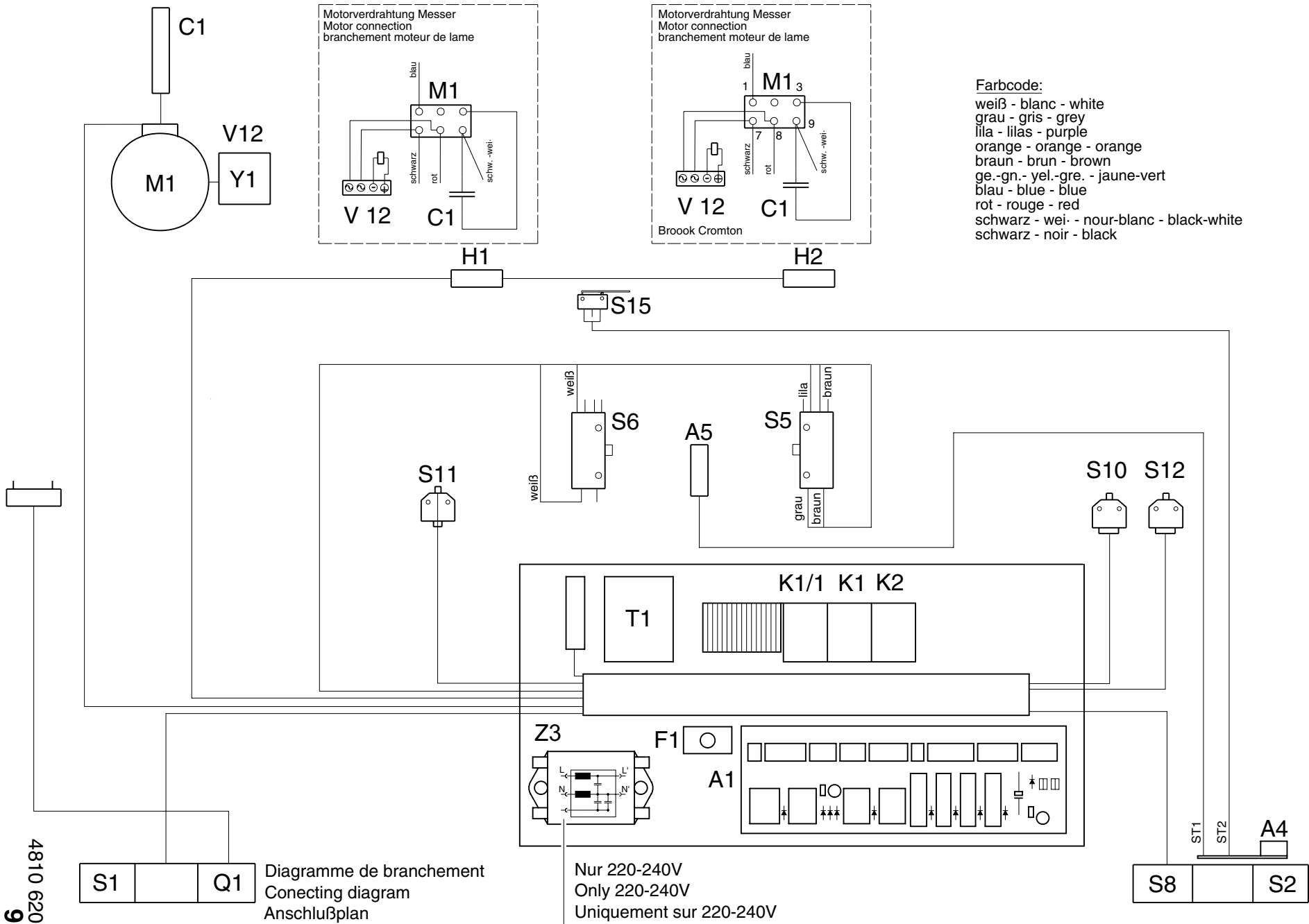

Farbcode:
 weiß - blanc - white
 grau - gris - grey
 lila - lilas - purple
 orange - orange - orange
 braun - brun - brown
 ge.-gn.- yel.-gre. - jaune-vert
 blau - blue - blue
 rot - rouge - red
 schwarz - wei. - noir-blanc - black-white
 schwarz - noir - black

4810 620
9

S1 Q1 Diagramme de branchement
Conecting diagram
Anschlußplan

Nur 220-240V
Only 220-240V
Uniquement sur 220-240V

Mod. 4810-95 B
01.08.2009

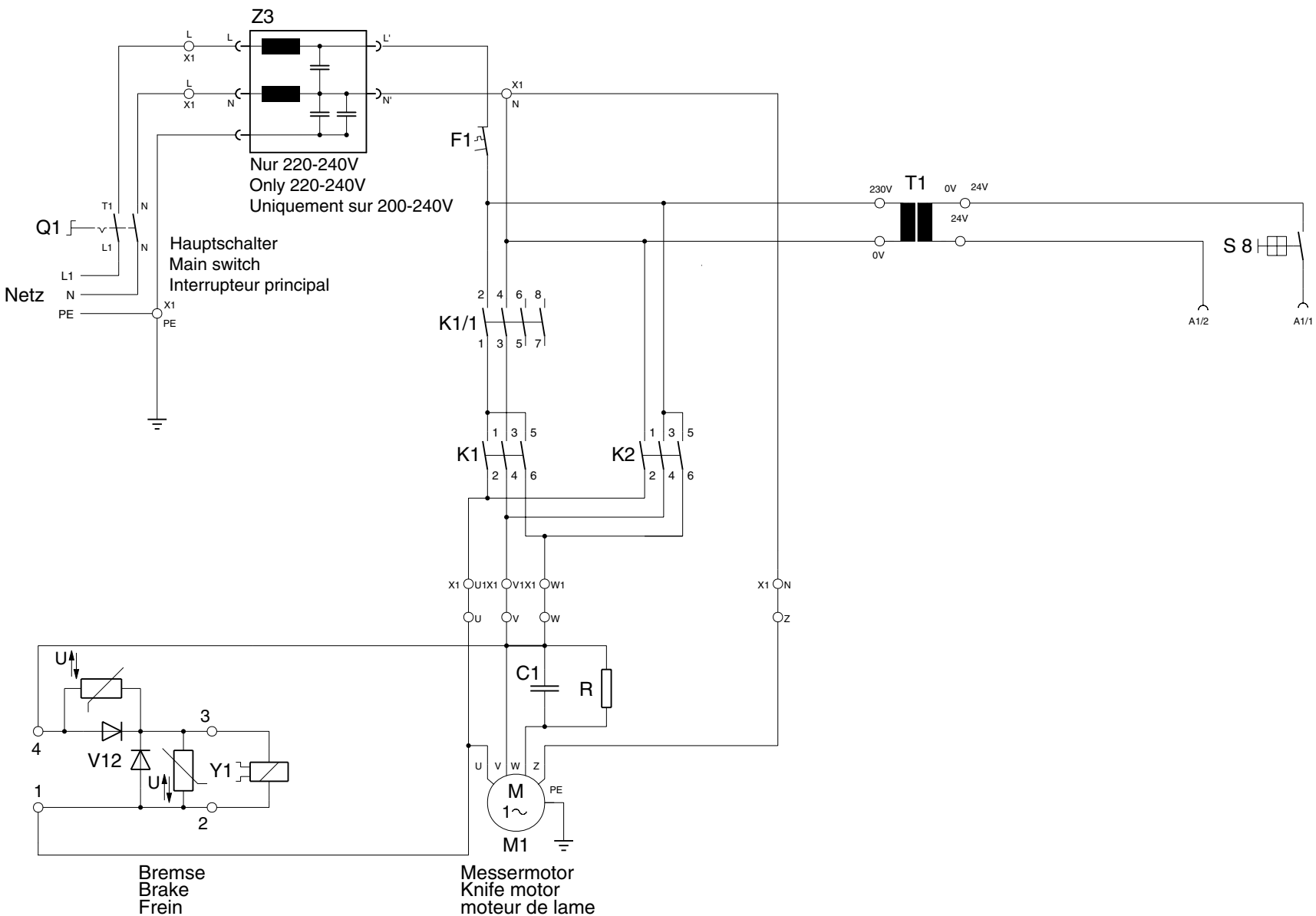

Mod. 4810-95 B

01.08.2009

Mod. 4810-95 B

01.08.2009

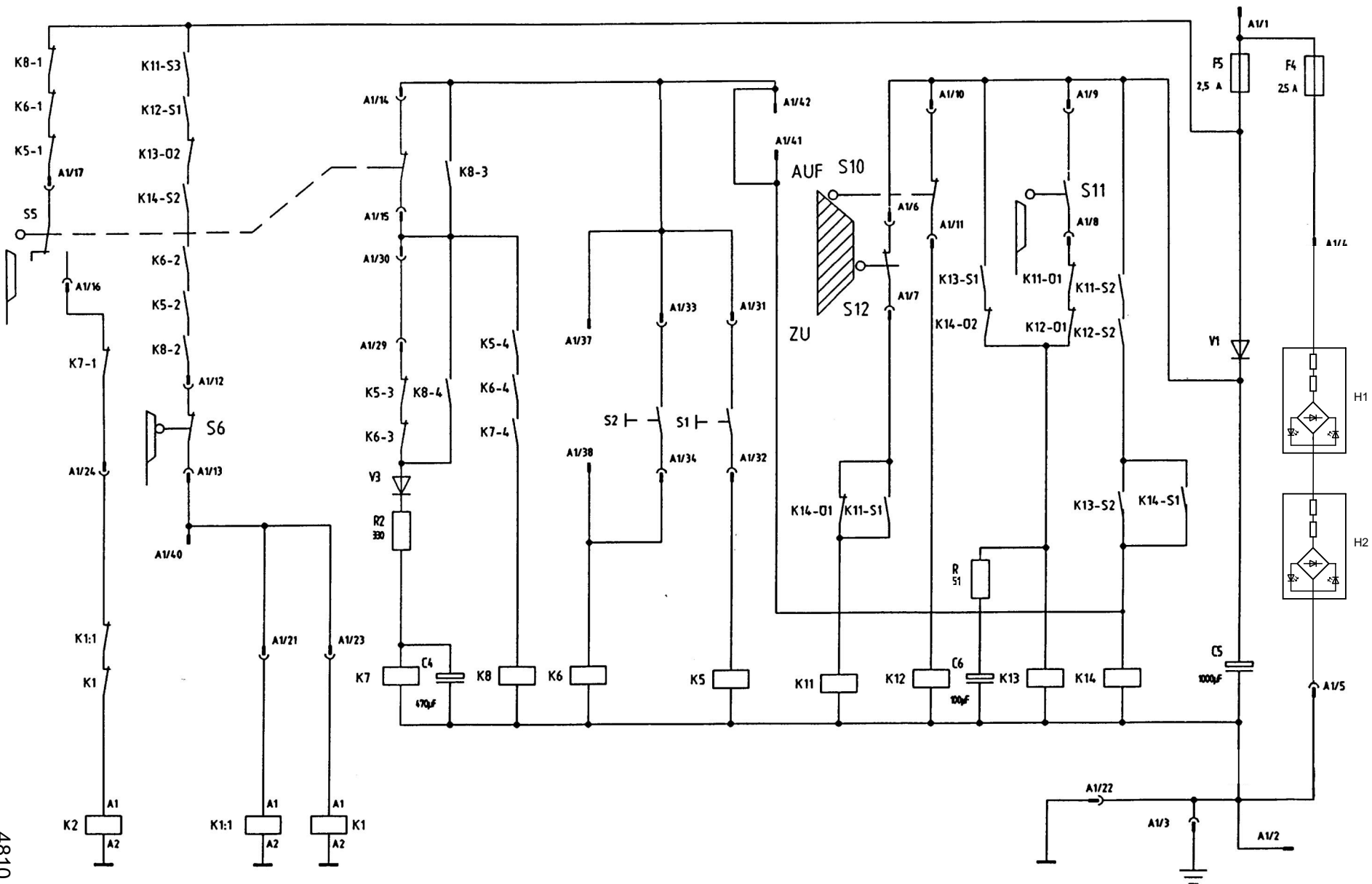

Index 4810-95

- 1 -

	Deutsch	English	Francais	Holländisch	Italiano	Espanol
A1	Platine Steuerung	PCB - control	Platine de commande	Stuurprint	Scheda controllo	Placa de control
A4	Platine Rückanschlag	PCB-backgauge	Platine butée arrière	Zadelmotorsturing	Scheda di battuta posteriore	Placa escuadra trasera
A5	Platine Geber	PCB-counter	Platine compteur d'impulsions	Print teller	Scheda contatore	Placa del contactor
C1	Kondensator	Capacitor	Condensateur	Condensator	Condensatore	Condensador
C4	Kondensator	Capacitor	Condensateur	Condensator	Condensatore	Condensador
C5	Kondensator	Capacitor	Condensateur	Condensator	Condensatore	Condensador
C6	Kondensator	Capacitor	Condensateur	Condensator	Condensatore	Condensador
F1	Überlastschutz Messer	Knife overload	Disjoncteur lame	Overbel.schakelaar mesm.	Interruttore sovraccarico lama	Disyuntor estribo cuchilla
F5	Sicherung	Fuse	Fusible	Zekering	Fusible	Fusible
H1	Schnittandeuter	Cutting line light	Ampoule ligne de coupe	Snijlijn-verlichting	Inticatore taglio	Luz línea de corte
H2	Schnittandeuter	Cutting line light	Ampoule ligne de coupe	Snijlijn-verlichting	Inticatore taglio	Luz línea de corte
K1	Schütz Messer ab	Knife-down contactor	Contacteur descente de lame	Relais- mes omlaag	Interruttore discesa lama	Contactor bajada cuchilla
K1/1	Schütz Messer ab	Knife-down contactor	Contacteur desconte de lame	Relais-mes omlaag	Interruttore discesa lama	Contactor bajada cuchilla
K2	Schütz Messer auf	Knife-up contactor	Contacteurremontée de lame	Relais-mes om hoog	Interruttore risalita lama	Contactor subida cuchilla
K5	Relais Taster links	Relay push button left	Relais touche gauche	Relais-drukknop links	Relais pulsante sinistro	Relé botón izquierdo
K6	Relais Taster rechts	Relay push button right	Relais touche droite	Relais-drukknop rechts	Relais pulsante destro	Relé botón derecho
K7	Relais Verzögerung	Time-delay relay	Relais retard	Vertragingrelais	Relais de ritardo	Relé de atraso
K8	Relais Schnittwiederholung	Relay Cutting repetition	Relais répétition de coupe	Relais-snijgangherhaling	Relais riperizione taglio	Relé repitición corte
K11	Sicherheitsrelais Klappe	Relay safety flap	Relais volet de sécurité	Veiligheidsrelaiskap	Relais coperchio sicurezza	Relé tapa de seguridad
K12	Sicherheitsrelais Klappe	Relay safety flap	Relais volet de sécurité	Veiligheidsrelaiskap	Relais coperchio sicurezza	Relé tapa de seguridad

Index 4810-95

- 2 -

K13	Sicherheitsrelais Klappe	Relay safety flap	Relais volet de sécurité	Veiligheidsrelaiskap	Relais coperchio sicurezza	Relé tapa de seguridad
K14	Sicherheitsrelais Klappe	Relay safety flap	Relais volet de sécurité	Veiligheidsrelaiskap	Relais coperchio sicurezza	Relé tapa de seguridad
M1	Antriebsmotor	Cutting motor	Moteur de coupe	Snijmotor	Motore lama	Motor de corte
Q1	Hauptschalter	Main switch	Interruteur principal	Hoofdschakelaar	Interruttore principale	Interruptor principal
R2	Widerstand	Resistor	Résistance	Weerstand	Resistenza	Resistencia
S1	Taster Messer ab	Push button knife	Touche de commande lame	Drukknop mes	Pulsante lama	Botón de la cuchilla
S2	Taster Messer ab	Push button knife	Touche de commande lame	Drukknop mes	Pulsante lama	Botón de la cuchilla
S5	OT-Stopschalter Messer	Switch knife top	Arrêt lame haut	Schakelaar mes boven	Fermo lama alto	Detención cuchilla arriba
S6	UT-Stopschalter Messer	Switch knife bottom	Arrêt lame bas	Schakelaar mes beneden	Fermo lama basso	Detención cuchilla abajo
S8	Schalt schloß	Key switch	Contacteur à clé	Sleutelschakelaar	Interruttore a chiave	Llave del interruptor
S10	Sicherheitsschalter Klappe	Switch safety flap	Micro-contact volet	Veiligheidsschakelaar kap	Interrutt. coperchio sicurezza de sécurité	Interruptor tapa de seguridad
S11	Sicherheitsschalter Klappe	Switch safety flap	Micro-contact volet	Veiligheidsschakelaar kap	Interrutt. coperchio sicurezza de sécurité	Interruptor tapa de seguridad
S12	Sicherheitsschalter Klappe	Switch safety flap	Micro-contact volet	Veiligheidsschakelaar kap	Interrutt. coperchio sicurezza	Interruptor tapa de seguridad
S15	Rückanschlag vorne/Stop	Switchg backgauge	Fin de course avant forward/stop	Schakelaar schakelpunt voor butée arière de sécurité	Interruttore anteriore	Interruptor marca frontal
T1	Transformator	Transformer	Transformateur	Transformator	Traformatore	Transformador
V1	Diode	Diode	Diode	Diode	Diodo	Diode
V2	Diode	Diode	Diode	Diode	Diodo	Diode
V3	Diode	Diode	Diode	Diode	Diodo	Diode
V12	Gleichrichter Bremse	Rectifier	Redresseur frein	Gelijkrichter-rem	Raddrizzatore freno	Rectificador
Y1	Bremse Messermotor	knife brake motor	Frein moteur de lame	Rem-snijmotor	freno motore lama	Freno motor cuchilla
Z3	Entstörfilter	RC - filter	Filtre RC	Onstoorfilter	Filtro-antidisturbo	Filtro RC suppressor

Index 4810-95 B

Mod. 4810-95 B
01.08.2009

Mod.4810-95 B

01.08.2009

