

Mod.4315 A

01.01.2011

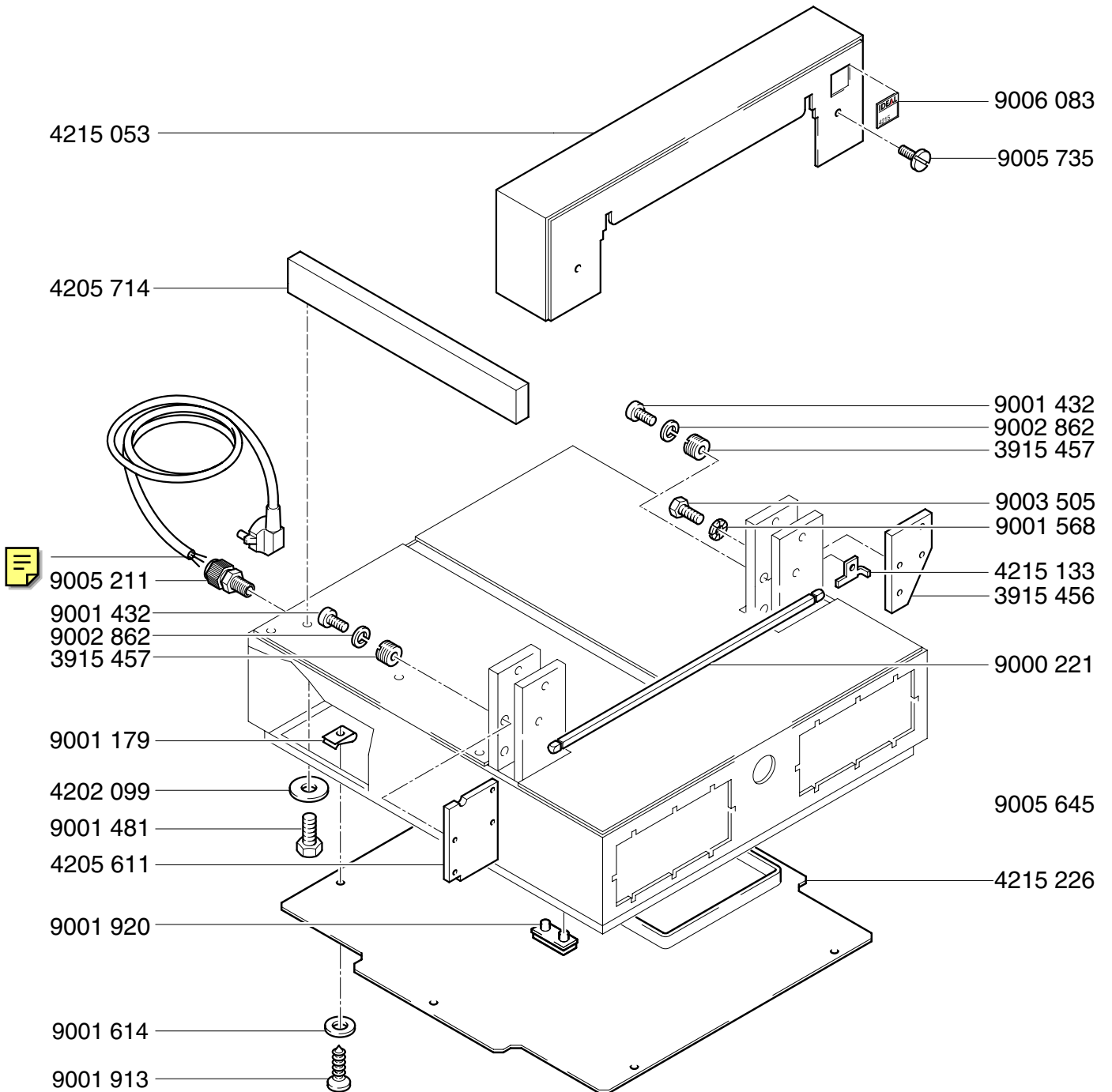

Mod.4315 A

01.01.2011

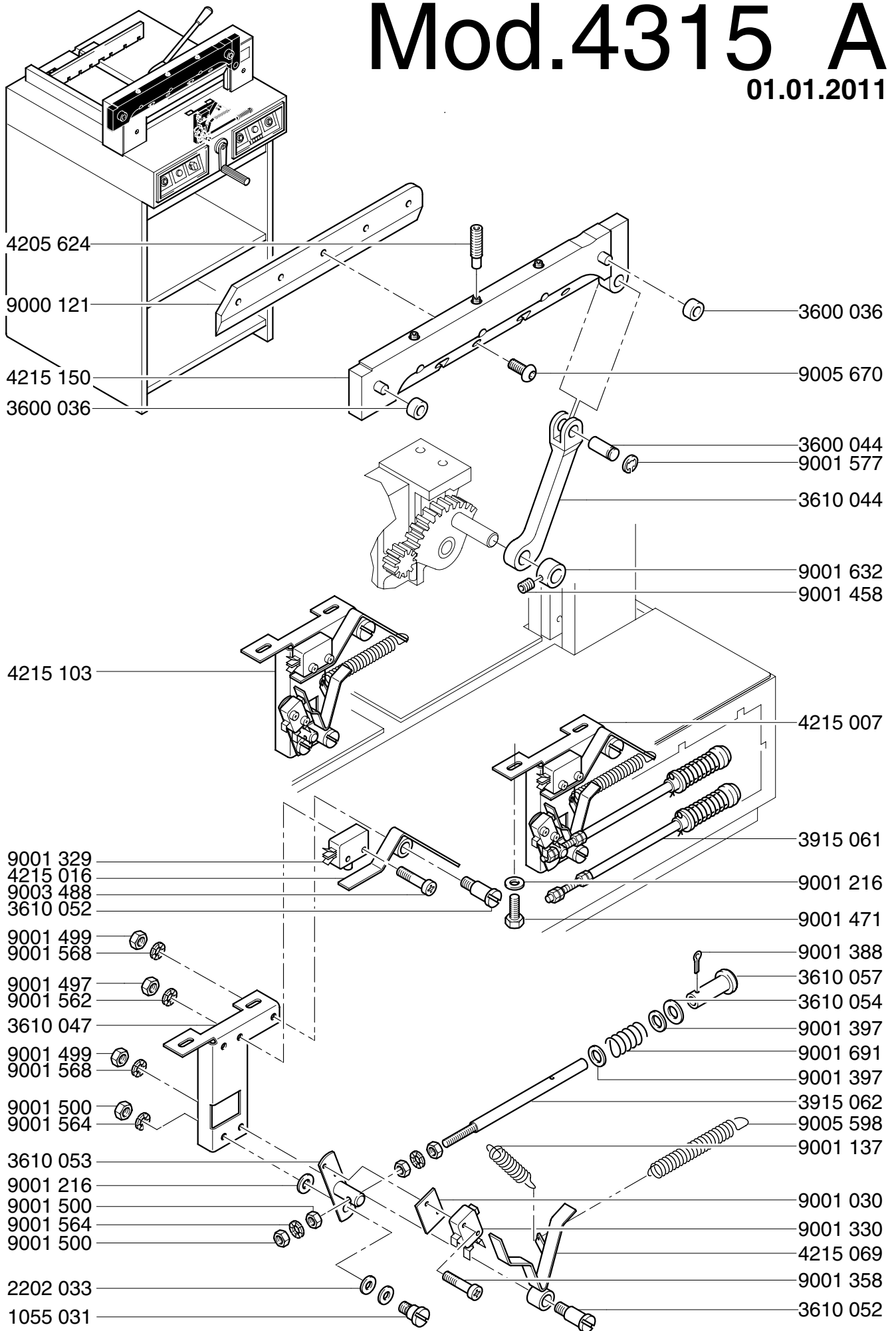

Mod.4315 A

01.01.2011

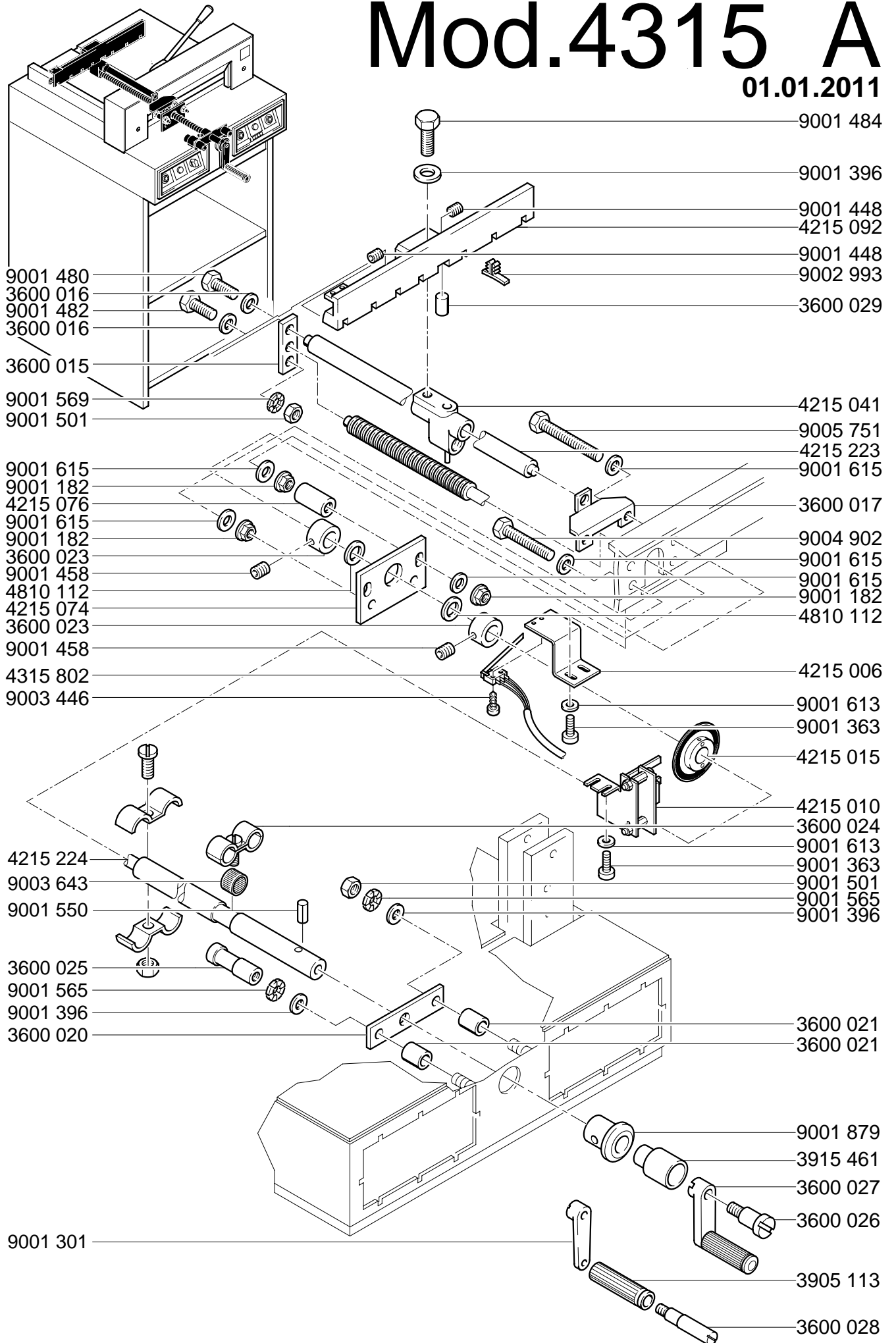

Mod.4315 A

01.01.2011

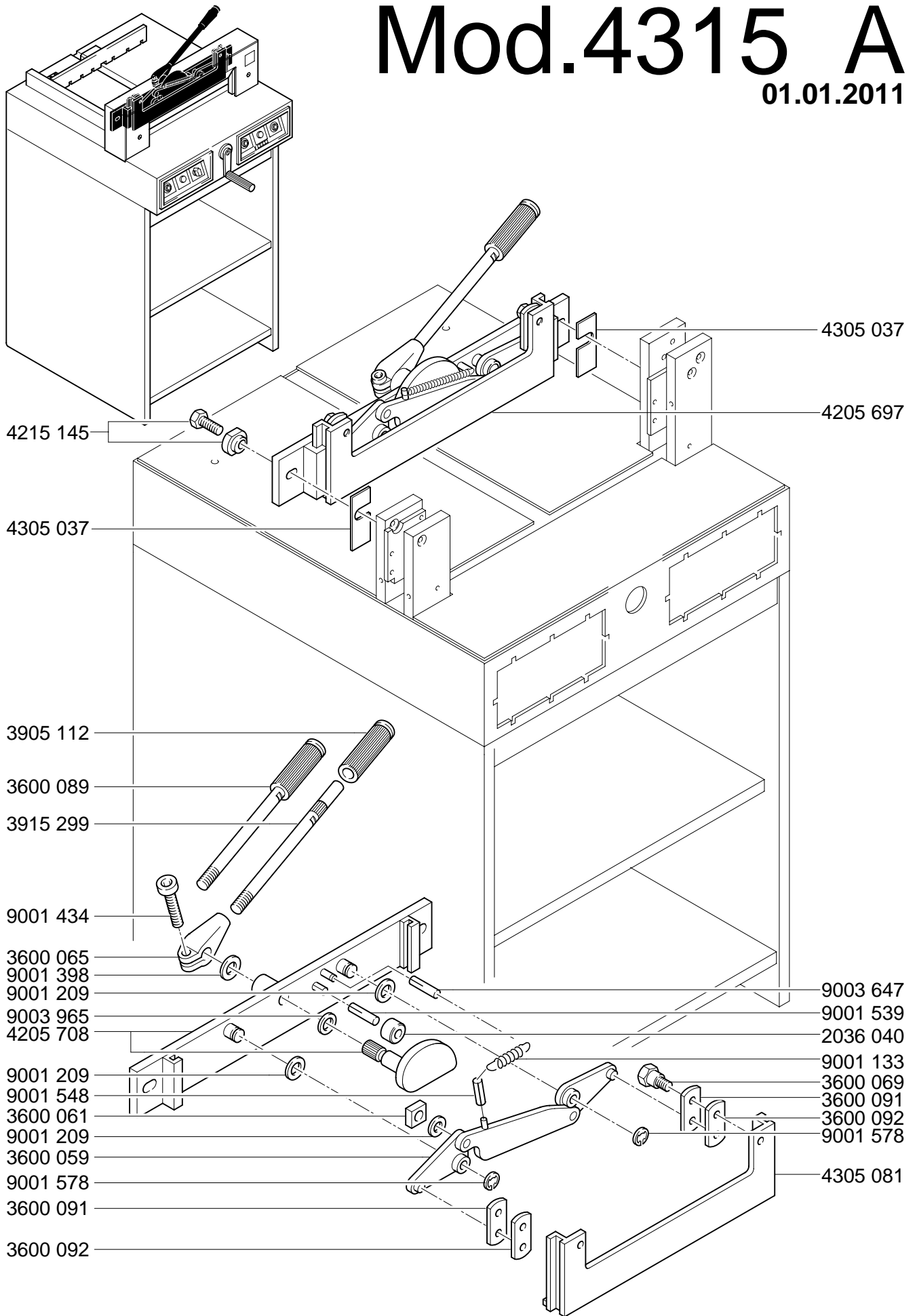

Mod.4315 A

01.01.2011

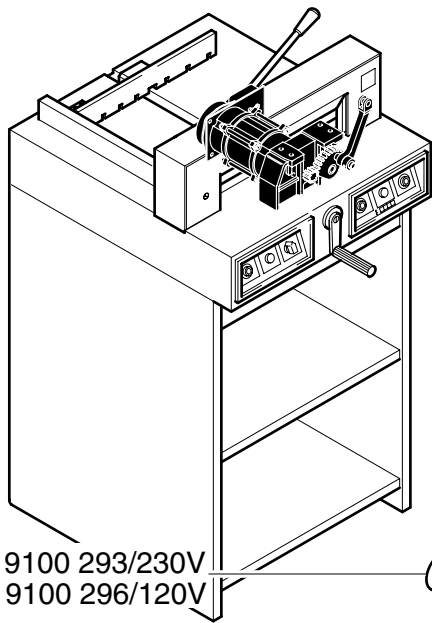

9100 293/230V
9100 296/120V

4215 101/230V/50Hz
4215 110/120V/50-60Hz
4215 111/100V

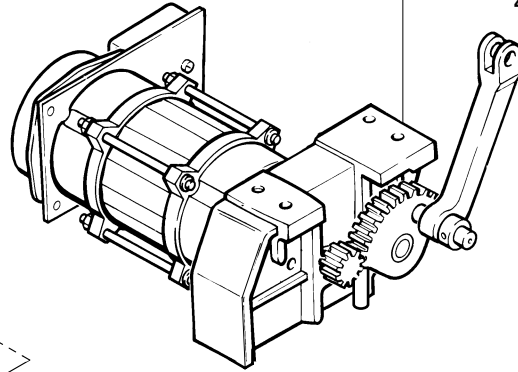

5250 174/230V
5250 184/120V
5250 194/100V

7228 437

9001 565/120-230V

9001 412/120-230V

3915 050

9001 468

9001 568

9001 584

9002 527/230V/50Hz
9002 528/100-120V/60Hz

9001 490

9001 397

3915 047

9001 472

9001 564

9001 458

9001 580

3610 027

9002 239

9001 199

9001 458

9001 191

3610 020

9001 458

3610 018

9001 869

3915 046

4215 102

9001 397

9001 490

3610 017

3915 042

3915 048

9001 199

9001 213

4215 042

3610 028

3610 022

3610 021

9003 084

3915 151

9001 668

9001 583

3915 045

Mod.4315 A

01.01.2011

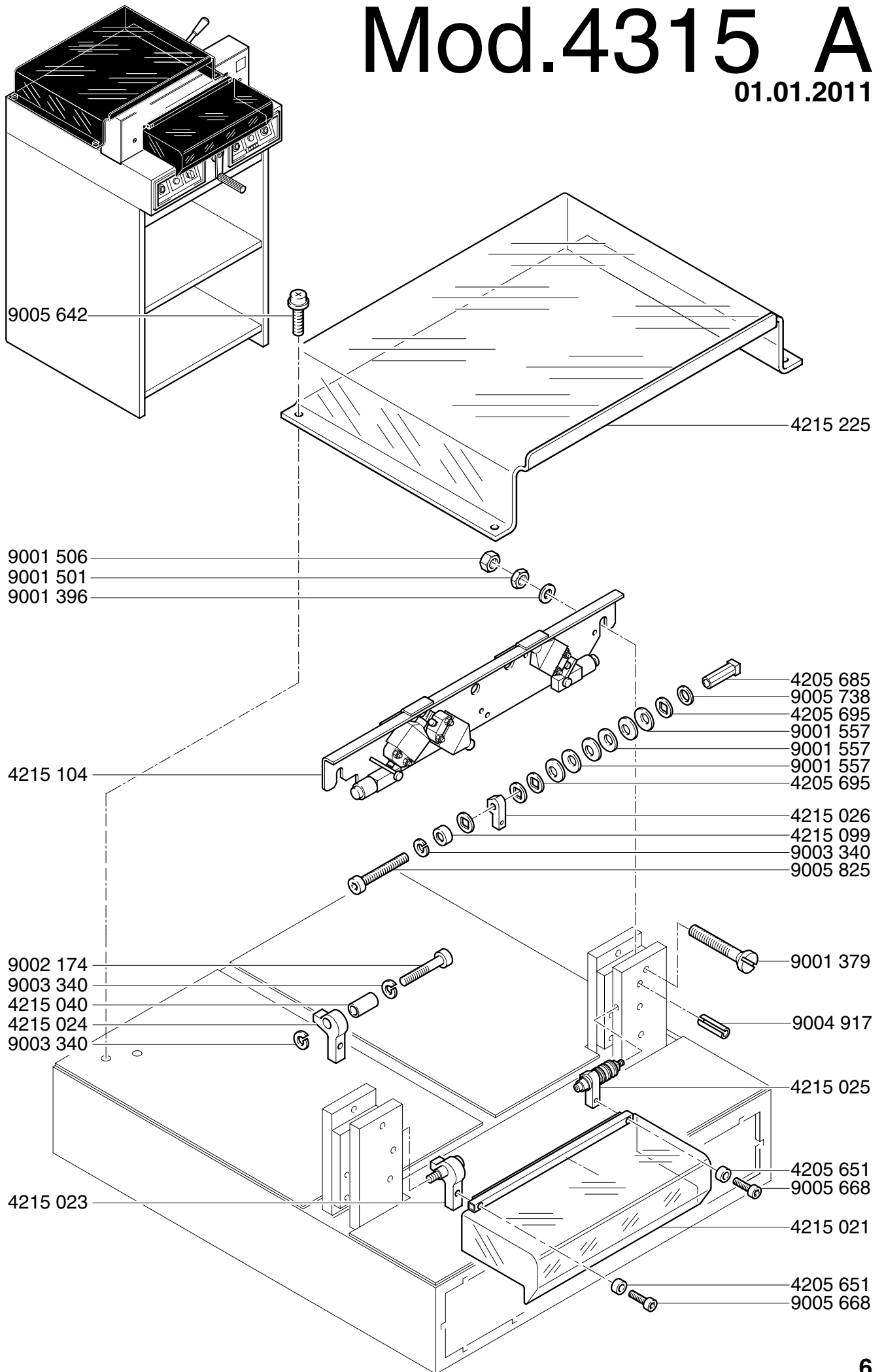

Mod.4315 A

01.01.2011

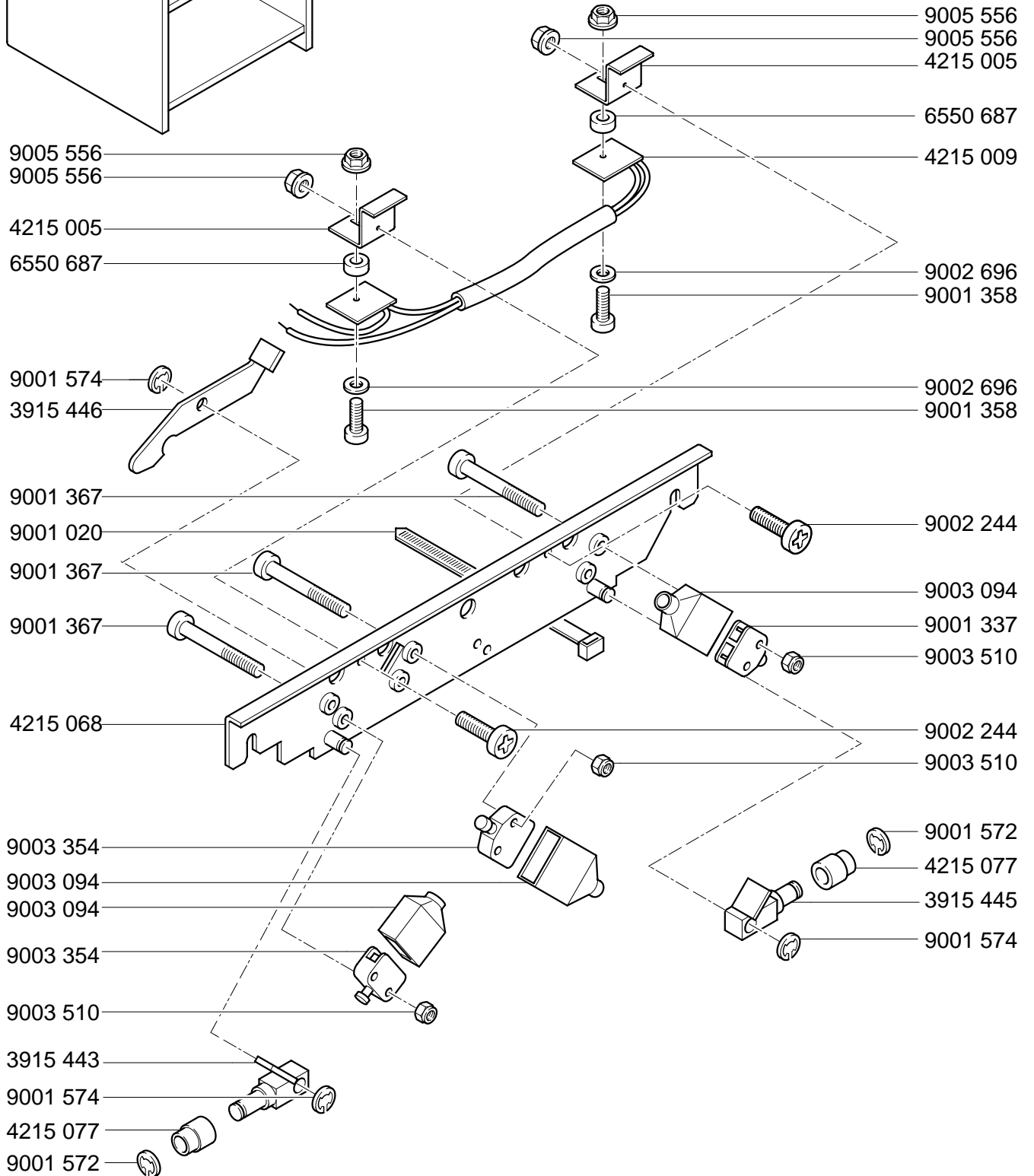
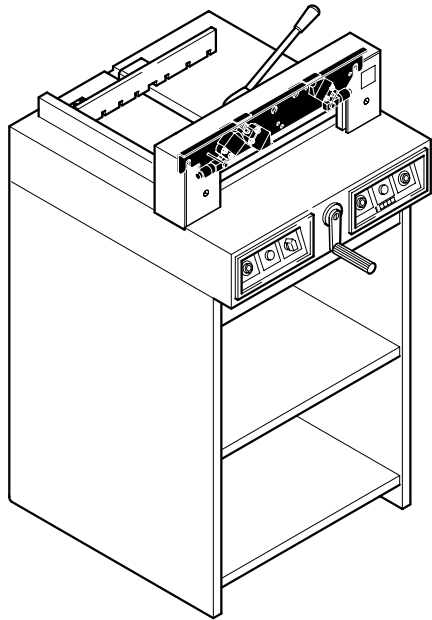

Mod.4315 A

01.01.2011

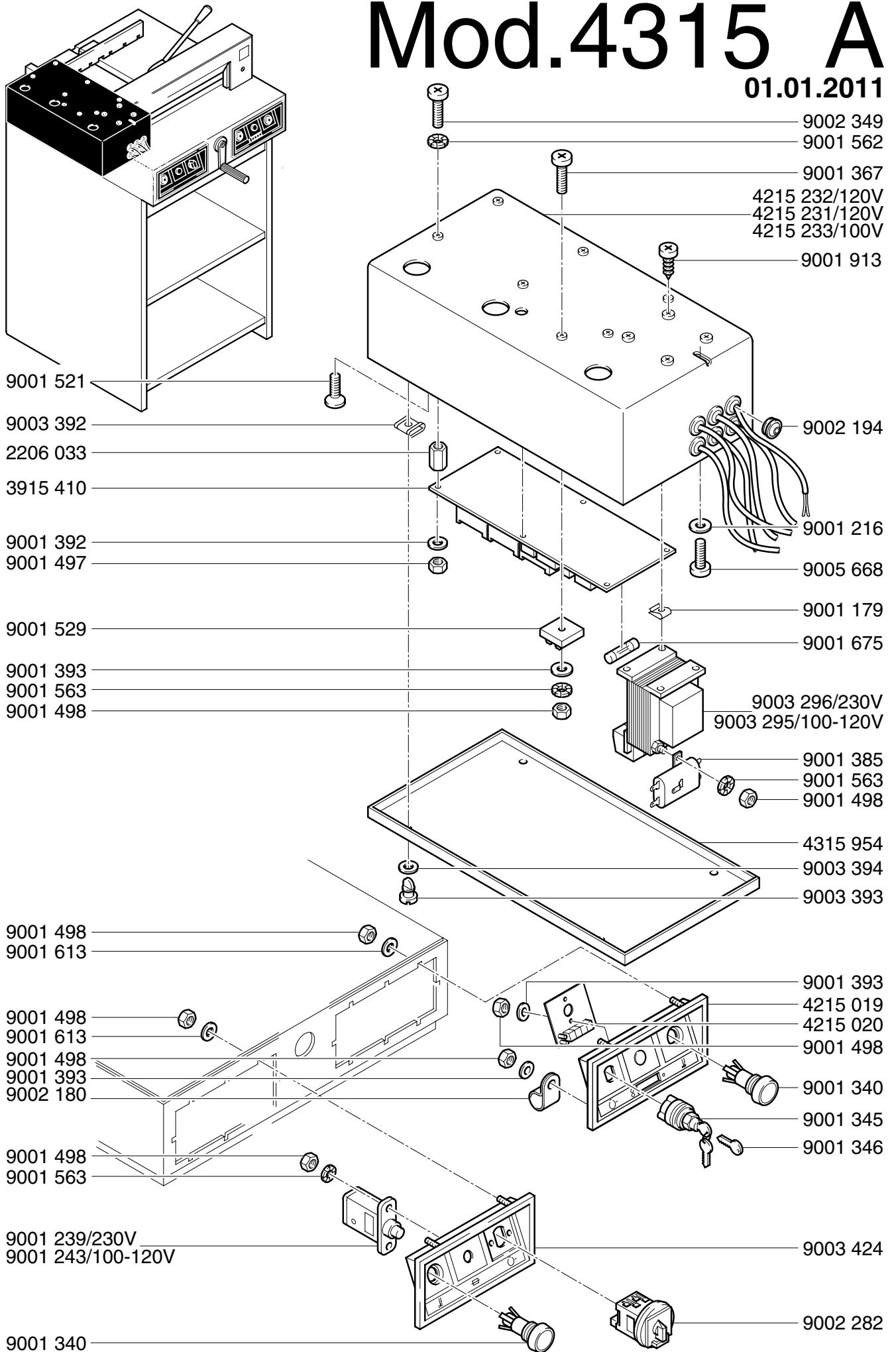

Mod.4315 A

01.01.2011

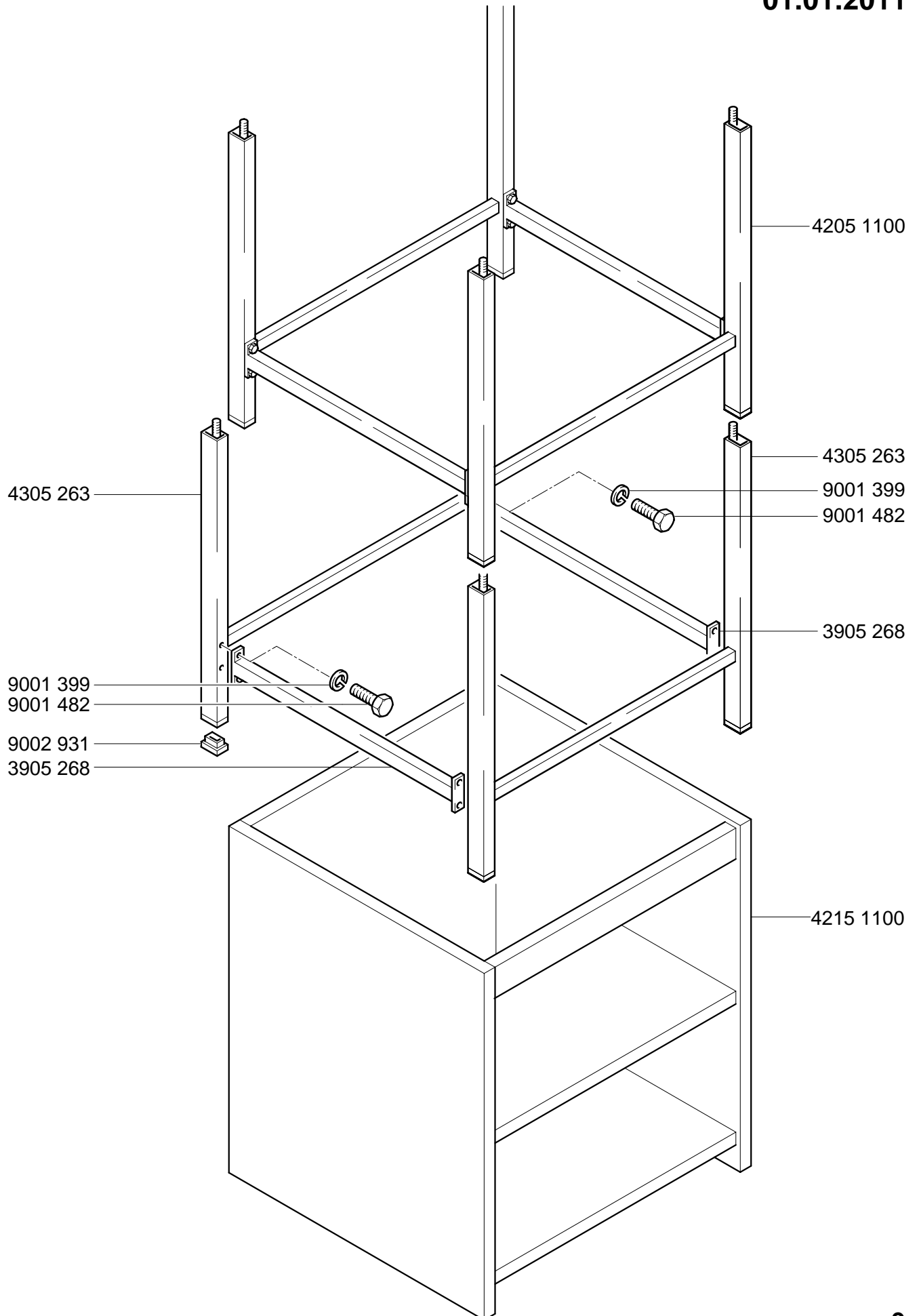

Hauptschalter
Main switch
Interrupteur principal

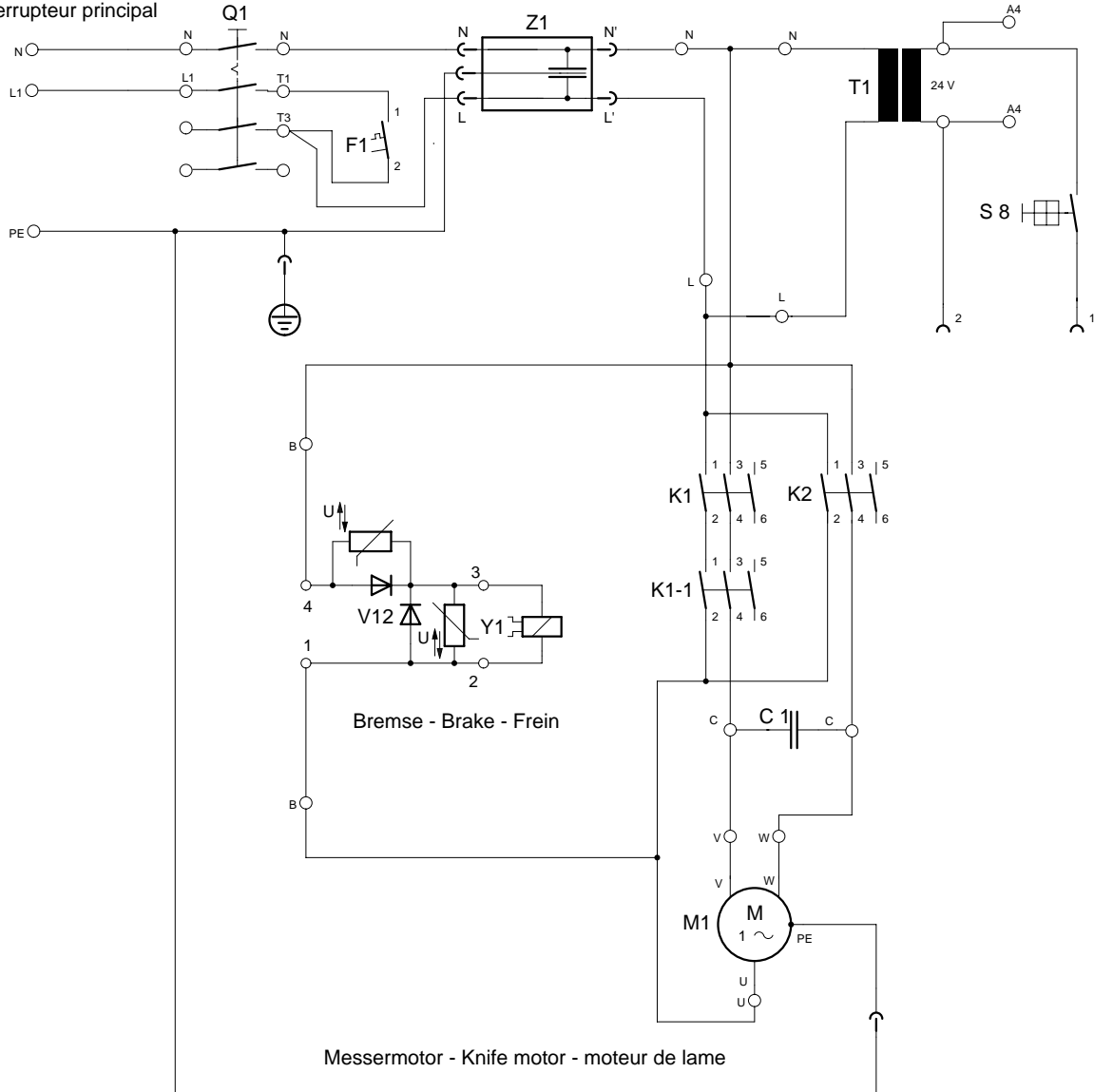

Farbcode:

- weiß - blanc - white
- grau - gris - grey
- lila - lilas - purple
- orange - orange - orange
- braun - brun - brown
- ge.-gn.- yel.-gre. - jaune-vert
- blau - blue - blue
- rot - rouge - red
- schwarz/weiß - noir/blanc - black/white
- schwarz - noir - black

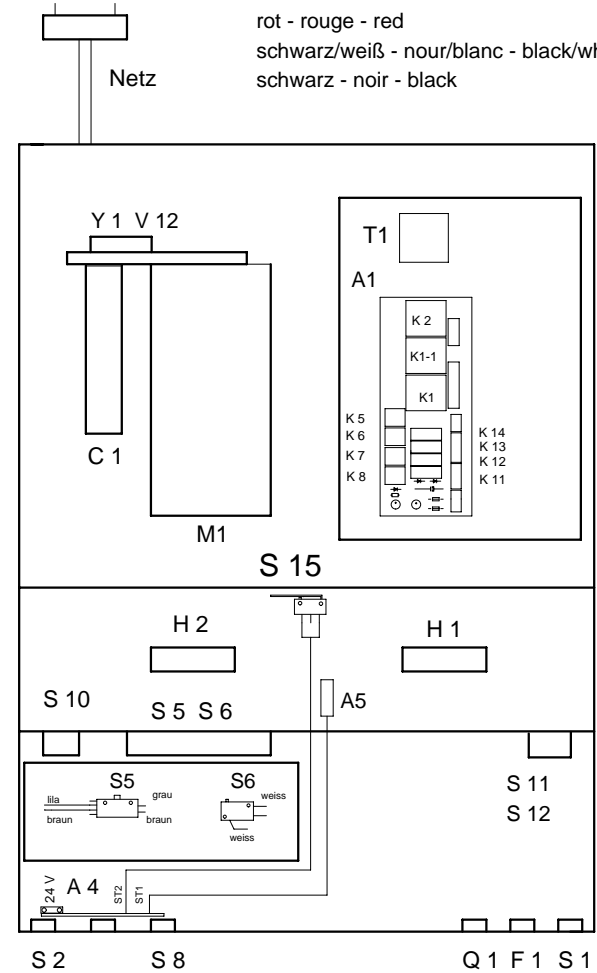

4215 080
10

Mod. 4315 A
01.01.2011

Mod. 4315 A

01.01.2011

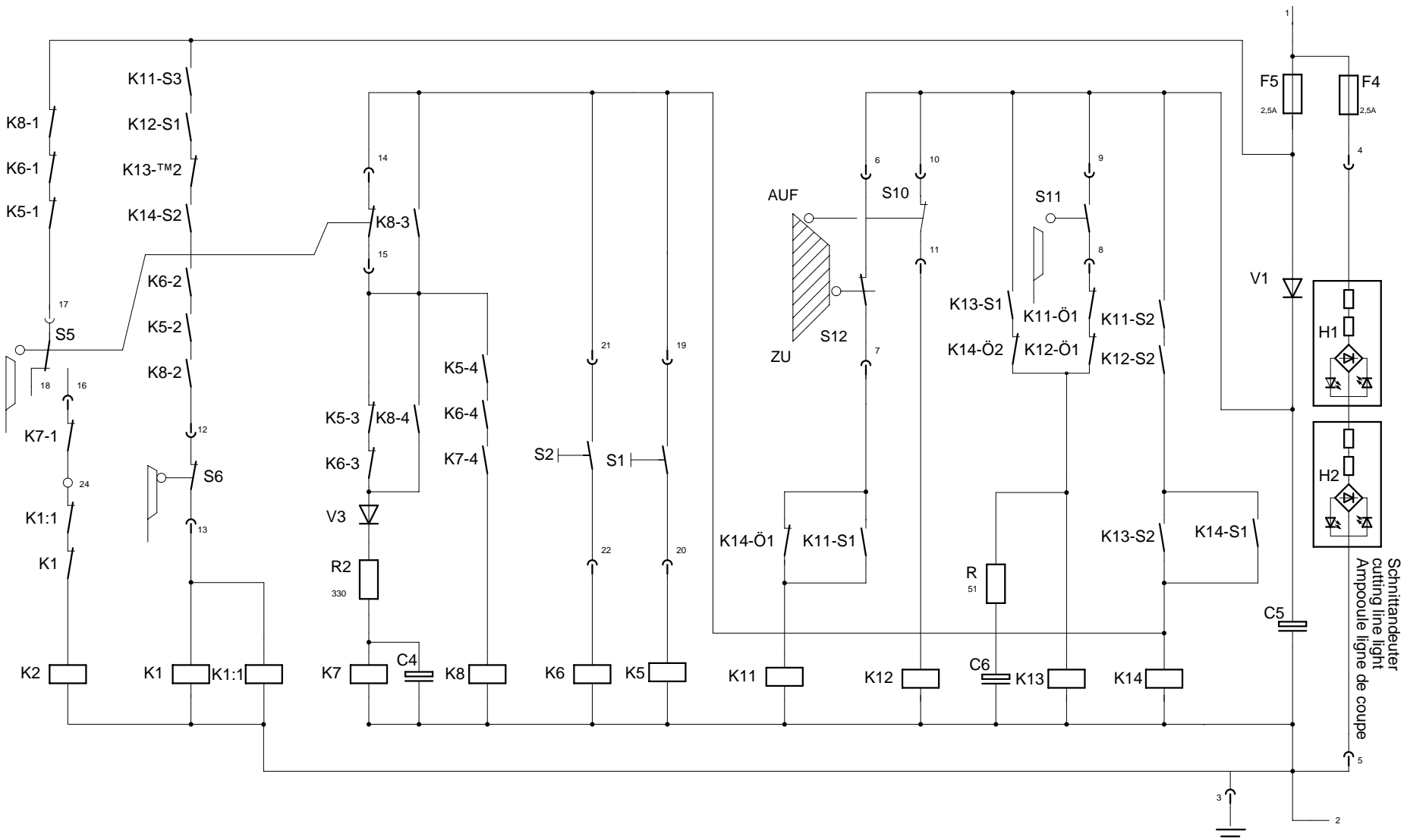

Index 4315

- 1 -

Code	Deutsch	English	Francais	Holländisch	Italiano	Espanol
A1	Platine Steuerung	PCB - control	Platine de commande	Stuurprint	Scheda controllo	Placa de control
A4	Platine Rückanschlag	PCB-backgauge	Platine butée arrière	Zadelmotorsturing	Scheda di battuta posteriore	Placa escuadra trasera
A5	Platine Geber	PCB-counter	Platine compteur d'impulsions	Print teller	Scheda contatore	Place del contacter
C1	Kondensator	Capacitor	Condensateur	Condensator	Condensatore	Condensador
C4	Kondensator	Capacitor	Condensateur	Condensator	Condensatore	Condensador
C5	Kondensator	Capacitor	Condensateur	Condensator	Condensatore	Condensador
C6	Kondensator	Capacitor	Condensateur	Condensator	Condensatore	Condensador
F1	Überlastschutz Messer	Knife overload	Disjoncteur lame	Overbel.schakelaar mesm.	Interruttore sovraccarico lama	Disyuntor estribo cuchilla
F4	Sicherung	Fuse	Fusible	Zekering	Fusible	Fusible
F5	Sicherung	Fuse	Fusible	Zekering	Fusible	Fusible
H1	Schnittandeuter	Cutting line light	Ampoule ligne de coupe	Snijlijn-verlichting	Indicatore taglio	Luz línea de corte
H2	Schnittandeuter	Cutting line light	Ampoule ligne de coupe	Snijlijn-verlichting	Indicatore taglio	Luz línea de corte
K1	Schütz Messer ab	Knife-down contactor	Contacteur descente de lame	Relais- mes omlaag	Interruttore discesa lama	Contactador bajada cuchilla
K1/1	Schütz Messer ab	Knife-down contactor	Contacteur desconte de lame	Relais- mes omlaag	Interruttore discesa lama	Contactador bajada cuchilla
K2	Schütz Messer auf	Knife-up contactor	Contacteurremontée de lame	Relais-mes om hoog	Interruttore risalita lama	Contactador subida cuchilla
K5	Relais Taster links	Relay push button left	Relais touche gauche	Relais-drukknop links	Relais pulsante sinistro	Relé botón izquierdo
K6	Relais Taster rechts	Relay push button right	Relais touche droite	Relais-drukknop rechts	Relais pulsante destro	Relé botón derecho
K7	Relais Verzögerung	Time-delay relay	Relais retard	Vertragingrelais	Relais de ritardo	Relé de atraso
K8	Relais Schnittwiederholung	Relay Cutting repetition	Relais répétition de coupe	Relais-snijgangherhaling	Relais riperizione taglio	Relé repitición corte
K11	Sicherheitsrelais Klappe	Relay safety flap	Relais volet de sécurité	Veiligheidsrelaiskap	Relais coperchio sicurezza	Relé tapa de seguridad

Index 4315

- 1 -

Code	Deutsch	English	Francais	Holländisch	Italiano	Espanol
K12	Sicherheitsrelais Klappe	Relay safety flap	Relais volet de sécurité	Veiligheidsrelaiskap	Relais coperchio sicurezza	Relé tapa de seguridad
K13	Sicherheitsrelais Klappe	Relay safety flap	Relais volet de sécurité	Veiligheidsrelaiskap	Relais coperchio sicurezza	Relé tapa de seguridad
K14	Sicherheitsrelais Klappe	Relay safety flap	Relais volet de sécurité	Veiligheidsrelaiskap	Relais coperchio sicurezza	Relé tapa de seguridad
M1	Antriebsmotor	Cutting motor	Moteur de lame	Snijmotor	Motore lama	Motor de corte
Q1	Hauptschalter	Main switch	Interrupteur principal	Hoofdschakelaar	Interruttore principale	Interruptor principal
R2	Widerstand	Resistor	Résistance	Weerstand	Resistenza	Resistencia
S1	Taster Messer ab	Push button knife	Touche de commande lame	Drukknop mes	Pulsante lama	Botón de la cuchilla
S2	Taster Messer ab	Push button knife	Touche de commande lame	Drukknop mes	Pulsante lama	Botón de la cuchilla
S5	OT-Stopschalter Messer	Switch knife top	Arrêt lame haut	Schakelaar mes boven	Fermo lama alto	Detención cuchilla arriba
S6	UT-Stopschalter Messer	Switch knife bottom	Arrêt lame bas	Schakelaar mes beneden	Fermo lama basso	Detención cuchilla abajo
S8	Schaltenschloß	Key switch	Contacteur á clé	Sleutelschakelaar	Interruttore a chiave	Llave del interruptor
S10	Sicherheitsschalter Klappe	Switch safety flap	micro contact volet de sécurité	Veiligheidsschakelaar kap	Interrutt. coperchio sicurezza	Interruptor tapa de seguridad
S11	Sicherheitsschalter Klappe	Switch safety flap	micro contact volet de sécurité	Veiligheidsschakelaar kap	Interrutt. coperchio sicurezza	Interruptor tapa de seguridad
S12	Sicherheitsschalter Klappe	Switch safety flap	micro contact volet	Veiligheidsschakelaar kap	Interrutt. coperchio sicurezza	Interruptor tapa de seguridad
S15	Rückanschlag vorne/Stop	Switchg backgauge forward/stop	Fin de course avant butée ariére de sécurité	Schakelaar schakelpunt voor	Interruttore anteriore	Interruptor marca frontal
T1	Transformator	Transformer	Transformateur	Transformator	Trafoformatore	Transformador
V1	Diode	Diode	Diode	Diode	Diodo	Diode
V3	Diode	Diode	Diode	Diode	Diodo	Diode
V12	Gleichrichter Bremse	Rectifier	Redresseur frein	Gelijkrichter-rem	Raddrizzatore freno	Rectificador
Y1	Bremse Messermotor	knife brake motor	Frein moteur de lame	Rem-snijmotor	freno motore lama	Freno motor cuchill
Z1	Drossel	Throttle	Self	Ontstoorspoel	Valvola di regolazione	Válvula reguladora

Mod.4315 A

01.01.2011

