

ProSource Packaging, Inc.
14911 Stuebner Airline Suite A
Houston, TX 77069
800-203-0233
www.Machine-Solution.com

MBM 93M

PARTS CATALOG

US0101
11. 01. 18

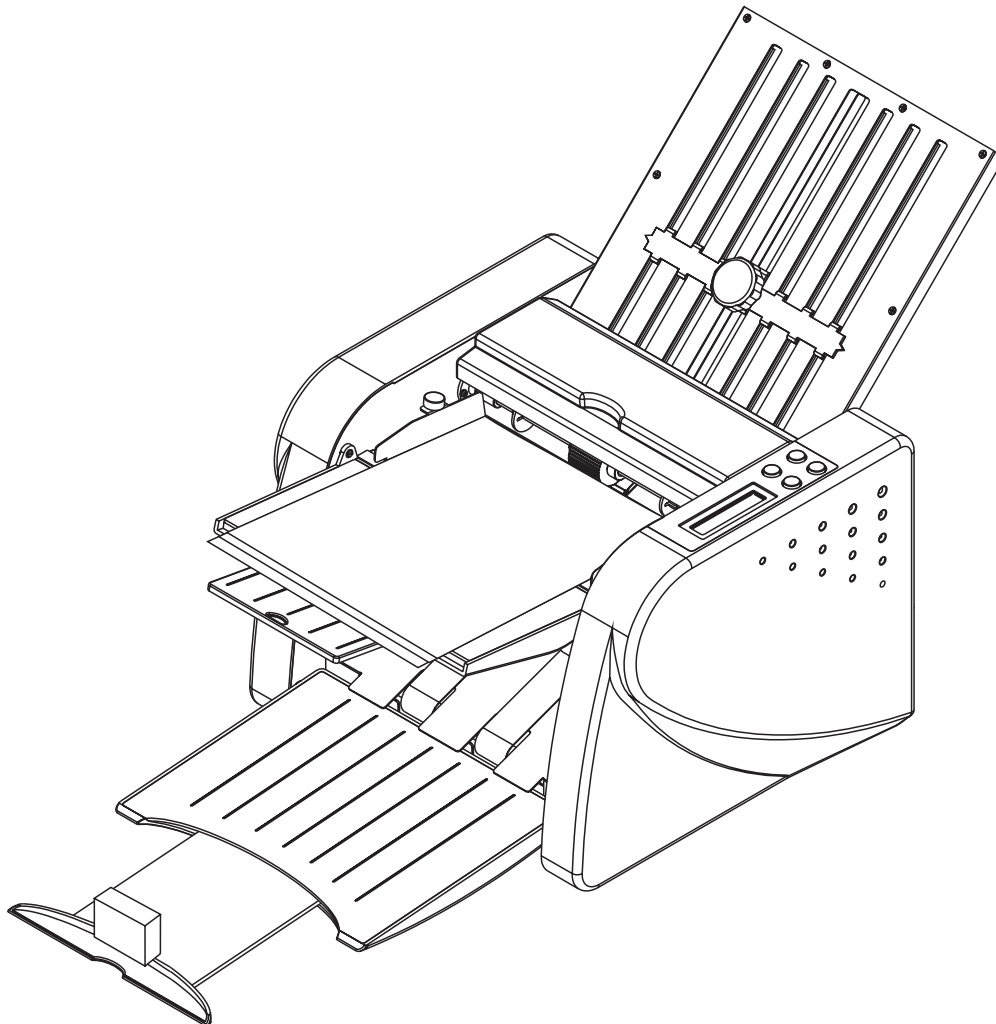
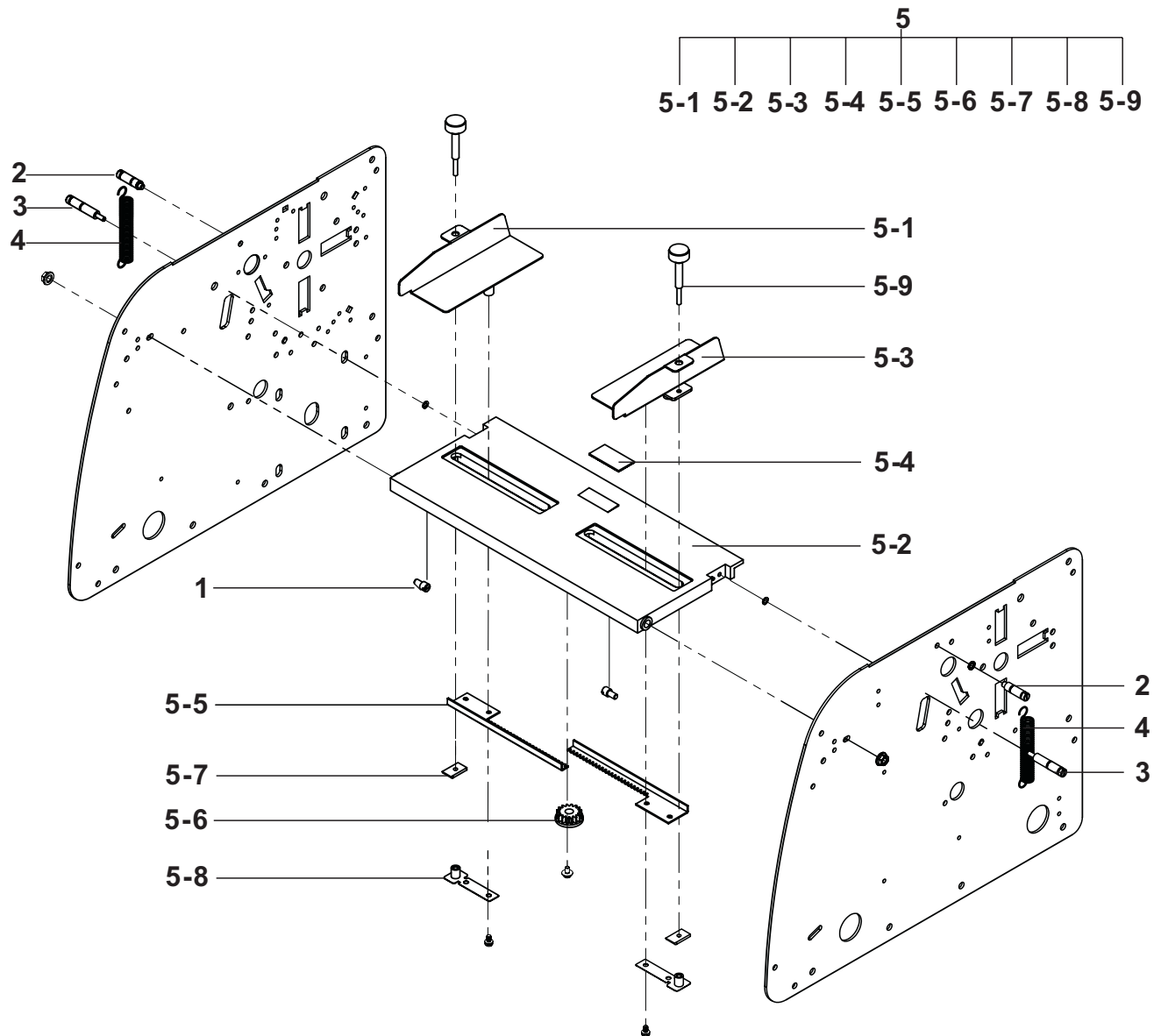

TABLE OF CONTENTS

n	PARTS CATALOG	
1.	PAPER FEED SECTION-----	1
2.	AUXILIARY PAPER FEED SECTION-----	2
3.	PAPER FEED SECTION-----	3
4.	PAPER FEED GATE-----	4
5.	PRESS ROLL SECTION-----	5
6.	DRIVING SECTION-----	6
7.	PAPER FEED DRIVING SECTION-----	7
8.	STACKER SECTION-----	8
9.	STACKER SECTION-----	9
10.	EJECTION SECTION-----	10
11.	CONTROL PANEL SECTION-----	11
12.	CONTROL PANEL SECTION-----	12
13.	FRAME SUB FRAME SECTION-----	13
14.	EXTERIOR-----	14
15.	FIRST FOLDING PLATE SECTION-----	15
16.	SECOND FOLDING PLATE SECTION-----	16
17.	WIRE CONNECTOR SECTION-----	17
18.	INDEX-----	18

1. PAPER FEED SECTION



INDEX	PARTS NO.	DESCRIPTION	C.DESCRPTION	QTY	REMARK
1	HF220D-00500	Pillar	挂钉	2	
2	HF230-103000	Spring pillar 1	拉簧支柱1	2	
3	HF230-104000	Spring pillar 2	拉簧支柱2	2	
4	HF220D-00900	Tension spring	拉伸弹簧	2	
5	HF230-101000	Paper feed plate unit assy	进纸台组合件	1	
5-1	HF230-101200	Paper guide L	左限位块组件	1	Part 5-1 to 5-9 are not for sell separately. They have to be purchased in a set HF230-101000.
5-2	HF230-101100	Paper feed plate	进纸台铸合件	1	
5-3	HF230-101300	Paper guide R	右限位块组件	1	
5-4	HF220D-00706	Backward stopper	防磨垫	1	
5-5	HF220D-00705	Rack	齿条	2	
5-6	HF220D-00704	Gear	小齿轮	1	
5-7	HF230-101500	Lock plate	锁紧板	2	
5-8	HF230-101600	Lock unit	托板组件	2	
5-9	HF230-101400	Set screw	调节螺丝	2	

2. AUXILIARY PAPER FEED SECTION

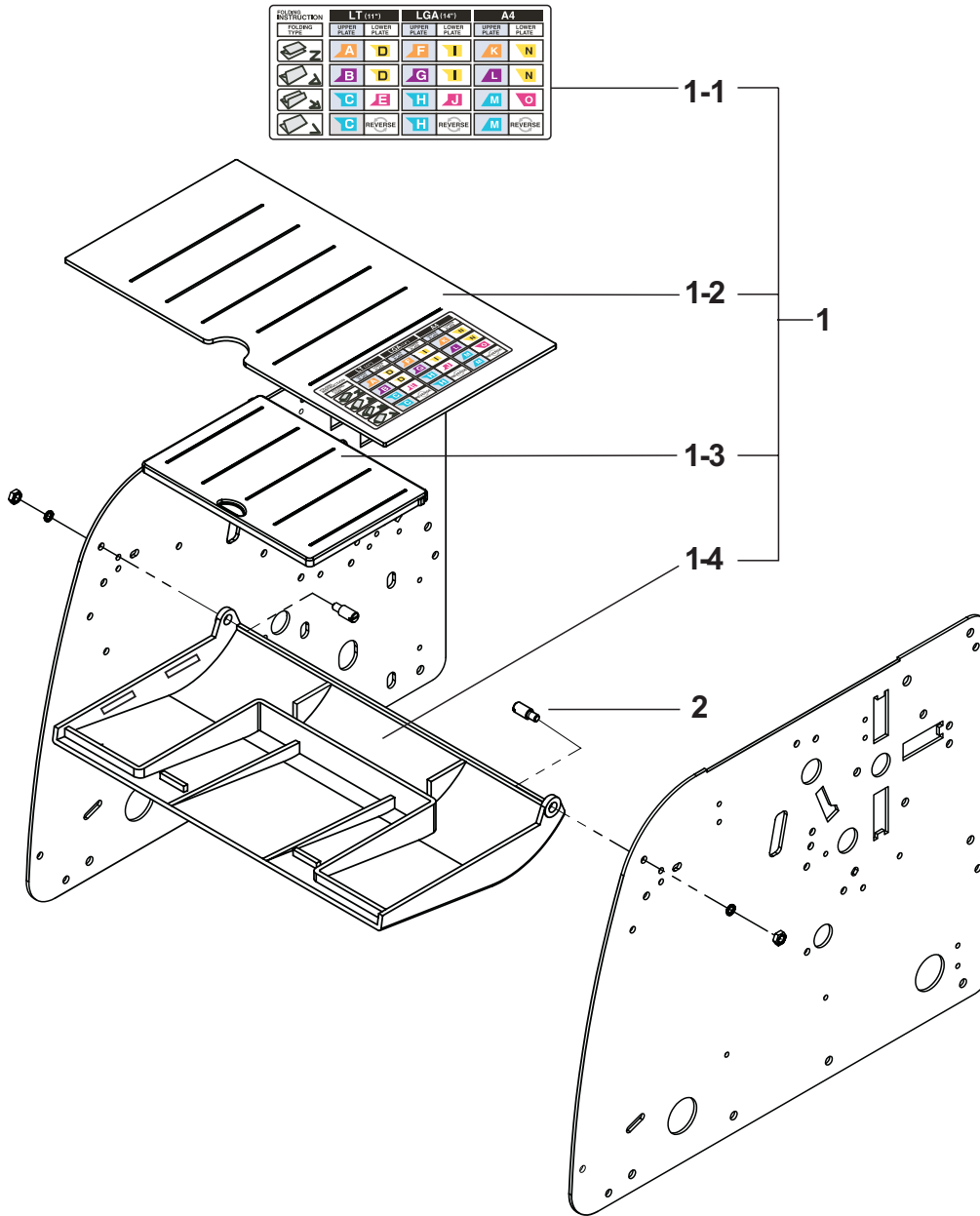

INDEX	PARTS NO.	DESCRIPTION	C.DESCRPTION	QTY	REMARK
1	HF230-106020	Auxiliary paper feed plate unit assy	辅助进纸台组合件	1	Part 1-1 to 1-4 are not for sell separately. They have to be purchased in a set HF230-106020.
1-1	HF230-830040	Instruction Label	折页对照表标签	1	
1-2	HF230-106300	Auxiliary paper feed plate (lower)	辅助进纸台下板	1	
1-3	HF230-106200	Draw-out unit	抽板	1	
1-4	HF230-106100	Auxiliary paper feed plate (upper)	辅助进纸台上板	1	
2	HF230-107000	Pillar	挂钉	2	

3. PAPER FEED SECTION

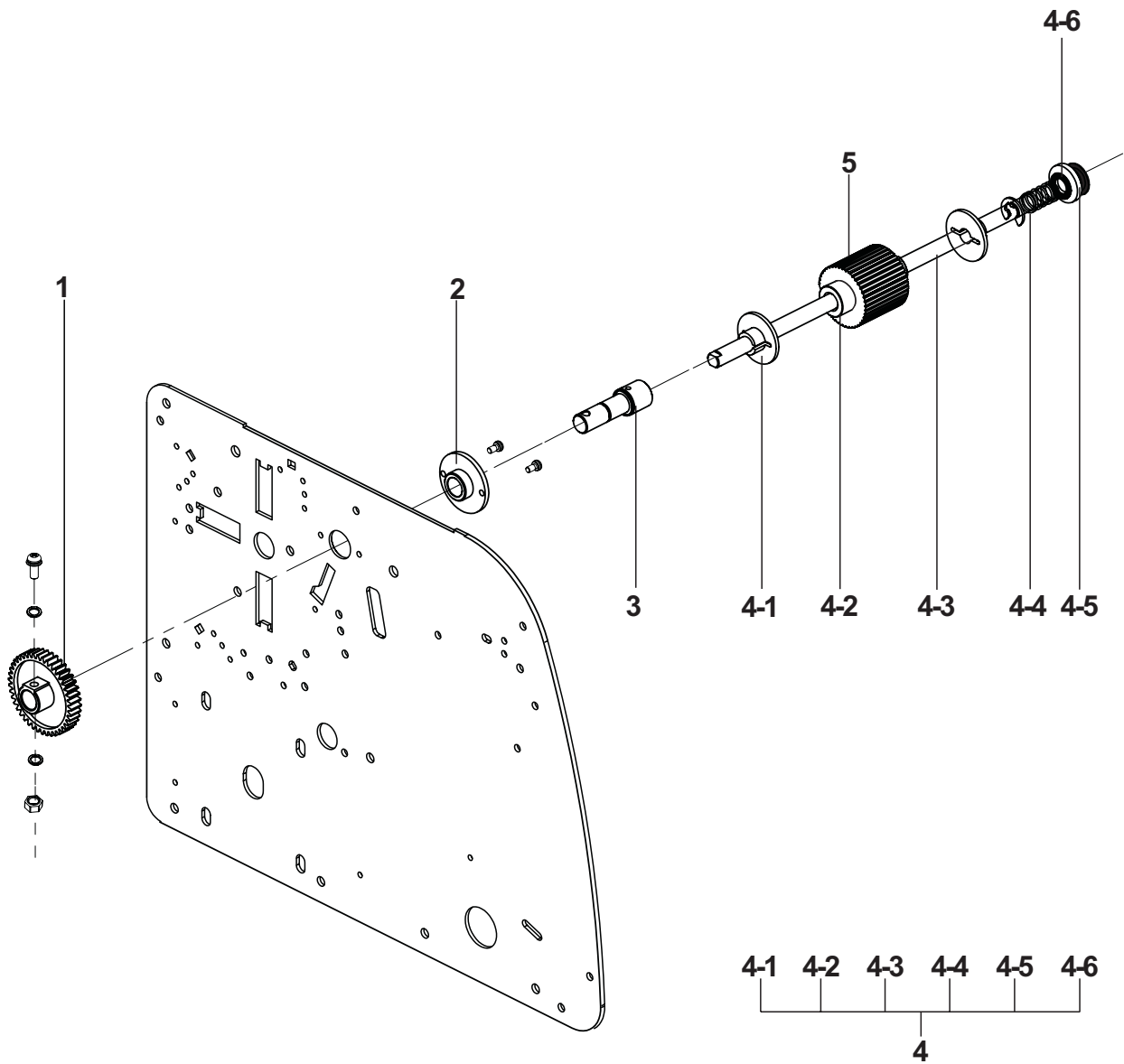

INDEX	PARTS NO.	DESCRIPTION	C.DESCRPTION	QTY	REMARK
1	96V-A1261	Gear (42T)	搓纸被动齿轮(42T)	1	
2	HF230-301300	Pivot suspension	短轴衬套	1	
3	HF230-301100	Shaft	连接轴组件	1	
4	HF220D-01300	Feed shaft Unit	搓纸轴组件	1	
4-1	HF220D-01304	Auxiliary feed roller	辅助送纸轮	2	Part 4-1 to 4-6 are not for sell separately. They have to be purchased in a set HF220D-01300.
4-2	HF220D-01303	Rubber ring boss	套子	1	
4-3	HF220D-01301	Feed shaft	搓纸轴	1	
4-4	HF220D-209030	Compression spring	压缩弹簧	1	
4-5	HF220D-01305	Bearing	活动套	1	
4-6	HF220D-01306	Washer	铜垫片	2	
5	HF220D-01302	Feed roller	搓纸轮	1	

4. PAPER FEED GATE

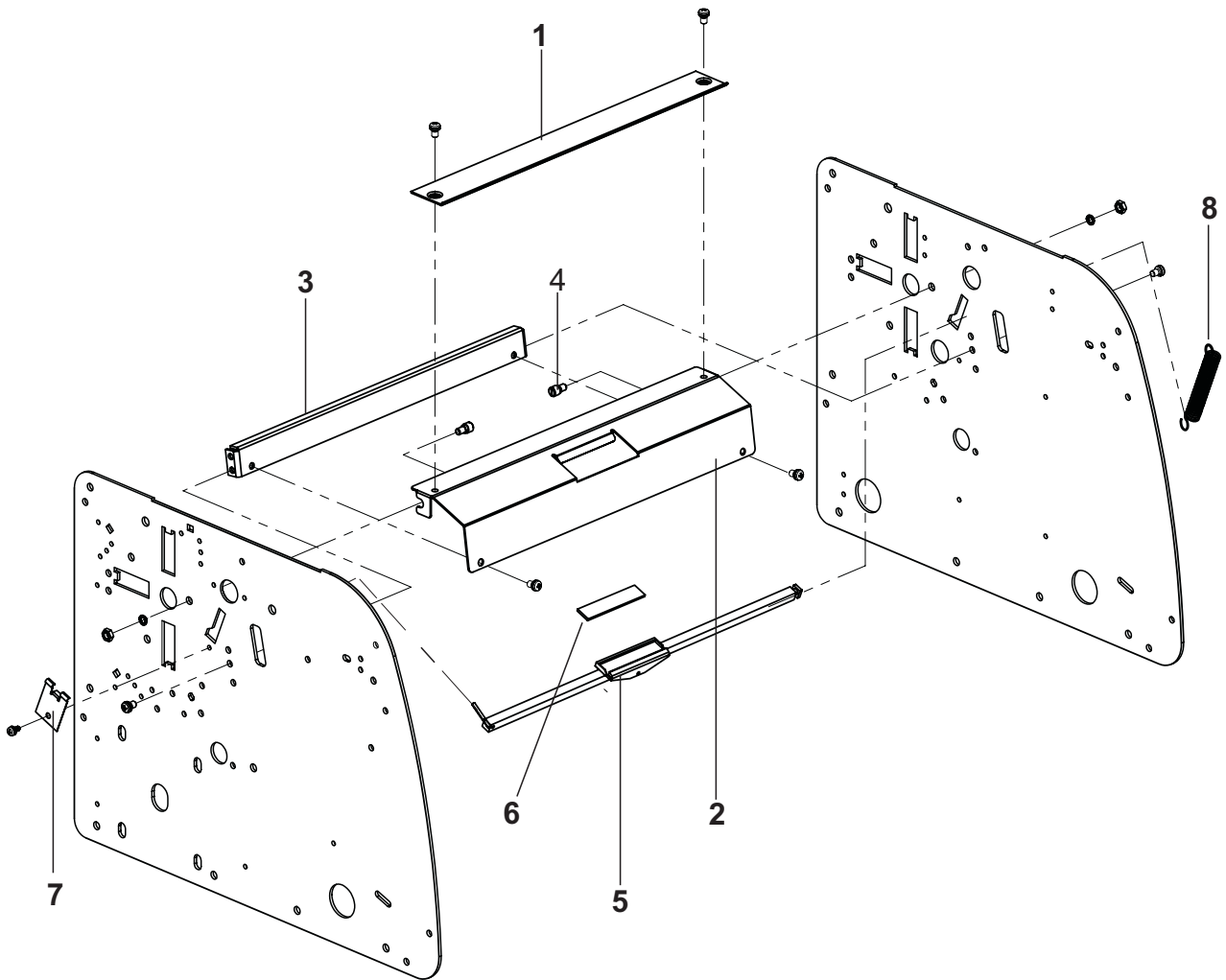

INDEX	PARTS NO.	DESCRIPTION	C.DESCRPTION	QTY	REMARK
1	HF230-102100	Paper feed guide (upper)	进纸上导板	1	
2	HF230-102200	Paper feed guide (lower)	进纸下导板	1	
3	HF230-102300	Frame	支撑板	1	
4	HF230-402800	Pillar	固定柱	2	
5	HF230-301600	Paper separator holder	分纸机构	1	
6	HF220D-01903	Paper separator	分纸板	1	
7	HF230-301700	Holder plate	支板	1	
8	HF230-301500	Tension spring (for squared shaft)	方轴拉簧	1	

5. PRESS ROLL SECTION

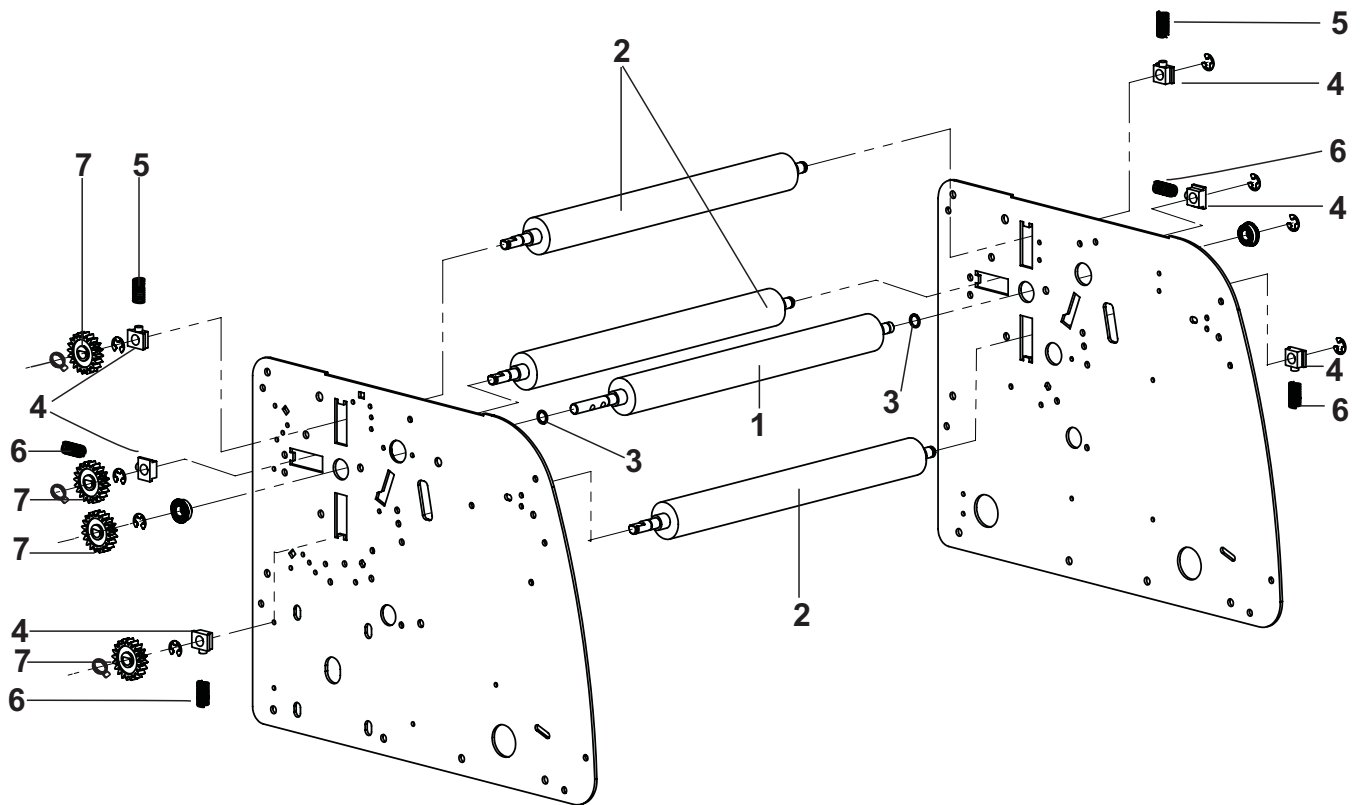

INDEX	PARTS NO.	DESCRIPTION	C.DESCRPTION	QTY	REMARK
1	HF230-201000	Press roller 1	折页辊1	1	
2	HF220D-035001	Press roller 2	折页辊2	3	
3	T00010	Washer(0.7mm)	垫片 0.7mm	2	
4	HF220D-032000	Press roller shaft set	折页辊轴套	6	
5	HF220D-03310	Compression spring (8 circle)	压簧8圈	2	
6	HF220D-03300	Compression spring (10 circle)	压簧10圈	4	
7	HF230-206000	Gear	小齿轮	4	

6. DRIVING SECTION

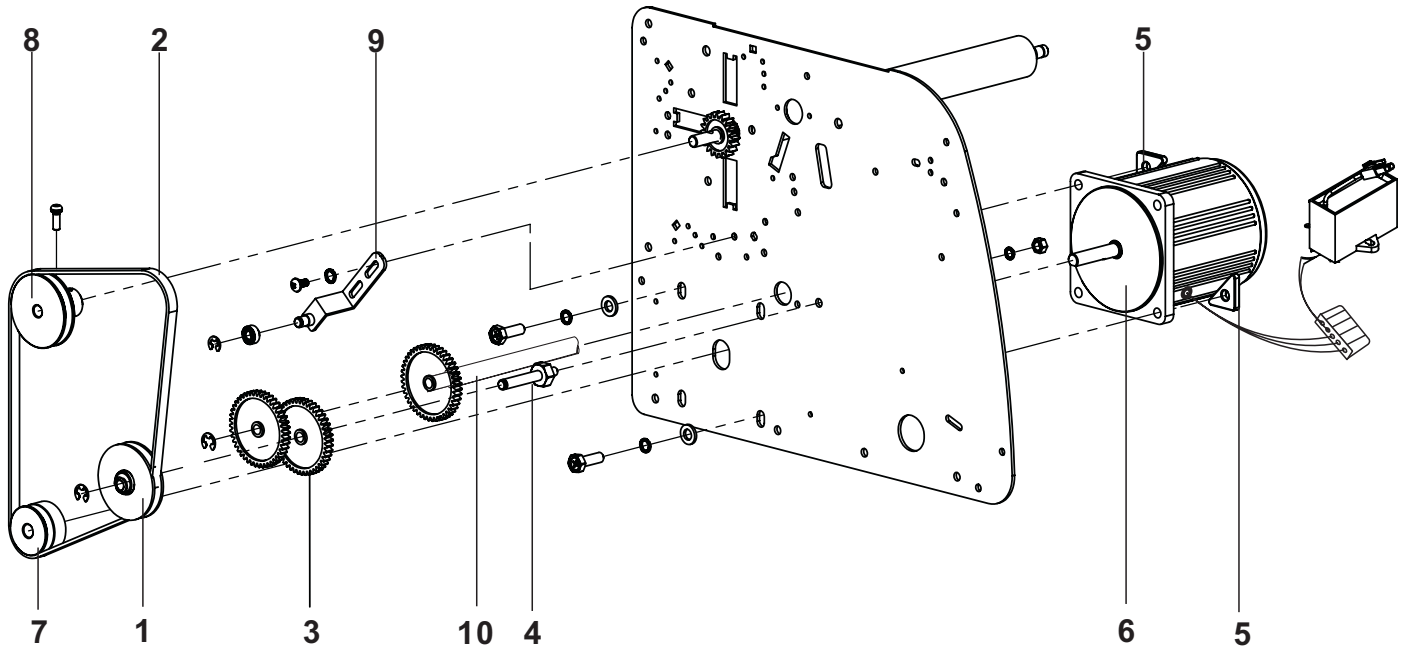

INDEX	PARTS NO.	DESCRIPTION	C.DESCRPTION	QTY	REMARK
1	HF230-205000	Pulley Unit	皮带轮组件	1	
2	HF230-730000	V belt	V型带	1	
3	96V-A2052	Gear	排纸齿轮	2	
4	96V-A2170	Upholding Pillar	支撑柱	1	
5	941-A0031	Locking plate	锁紧板	2	
6	HF230-910110	AC Motor (120V)	交流电机组件	1	
7	HF230-203000	Motor pulley	电机皮带轮	1	
8	HF230-204000	Pulley	折纸皮带轮	1	
9	HF230-720000	Pinch roller unit	涨紧轮架铆接件	1	
10	HF230-502000	Stacker primary gear unit	排纸主轴组合件	1	

7. PAPER FEED DRIVING SECTION

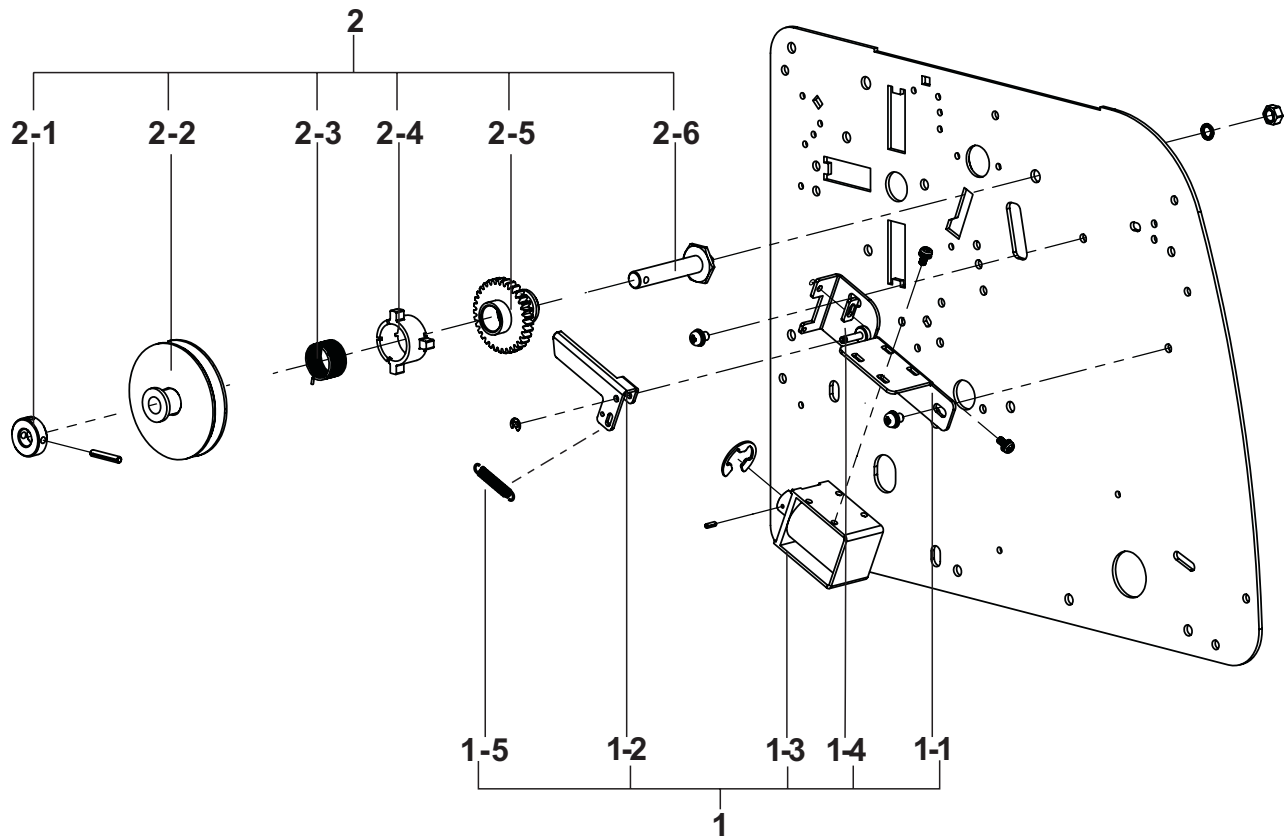

INDEX	PARTS NO.	DESCRIPTION	C.DESCRPTION	QTY	REMARK
1	HF230-207000	Solenoid unit	电磁铁组件	1	
1-1	96V-L0310	Clutch holder	离合器支架组件	1	Part 1-1 to 1-5 are not for sell separately. They have to be purchased in a set HF230-207000.
1-2	HF220D-195001	Lever	顶杆	1	
1-3	HDB-01	Solenoid	电磁铁	1	
1-4	96V-L0330	Clutch adjusting piece	离合器调节片	1	
1-5	96V-A1400	Tension spring	拉簧	1	
2	96V-A1101	Clutch unit	离合器组件	1	
2-1	941-A0181	Collar	挡圈	1	Part 2-1 to 2-6 are not for sell separately. They have to be purchased in a set 96V-A1101.
2-2	96V-11110	Pulley unit	搓纸皮带轮组件	1	
2-3	96V-A1190	Clutch spring	离合器弹簧	1	
2-4	HF220D-192000	Spring case	传力套	1	
2-5	96V-A1140	Gear unit	搓纸齿轮组件	1	
2-6	96V-A1170	Upholding pillar	支承柱	1	

8. STACKER SECTION

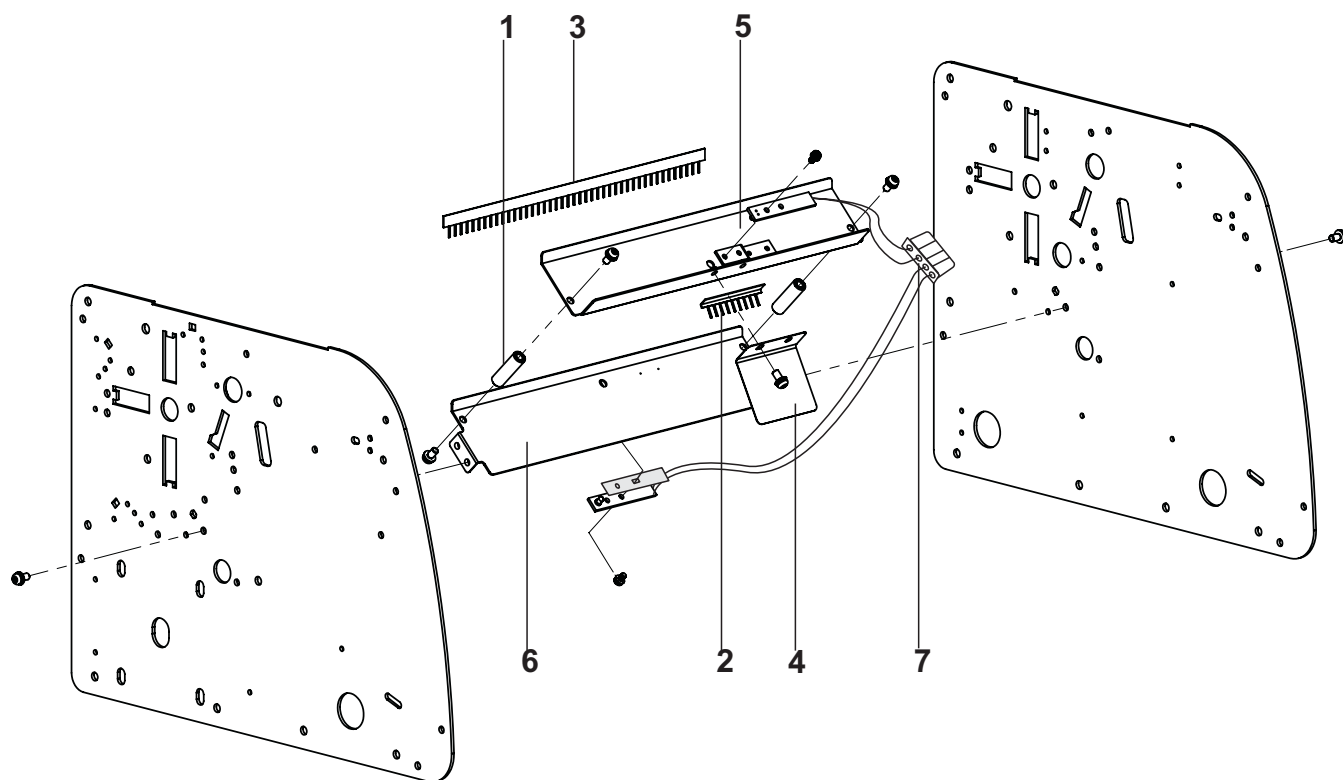

INDEX	PARTS NO.	DESCRIPTION	C.DESCRPTION	QTY	REMARK
1	HF230-506200	Collar	中间隔管	2	
2	HF230-507200	Anti-static brush 1	静电刷1	1	
3	HF230-506300	Anti-static brush 2	静电刷2	1	
4	HF230-506400	Stacker guide	排纸导板	1	
5	HF230-506100	Stacker guide unit(top)	排纸上导板组件	1	
6	HF230-507100	Stacker guide unit(bottom)	排纸下导板组件	1	
7	HF230-921100	Ejection light sensor	出纸光电组件	1	

9. STACKER SECTION

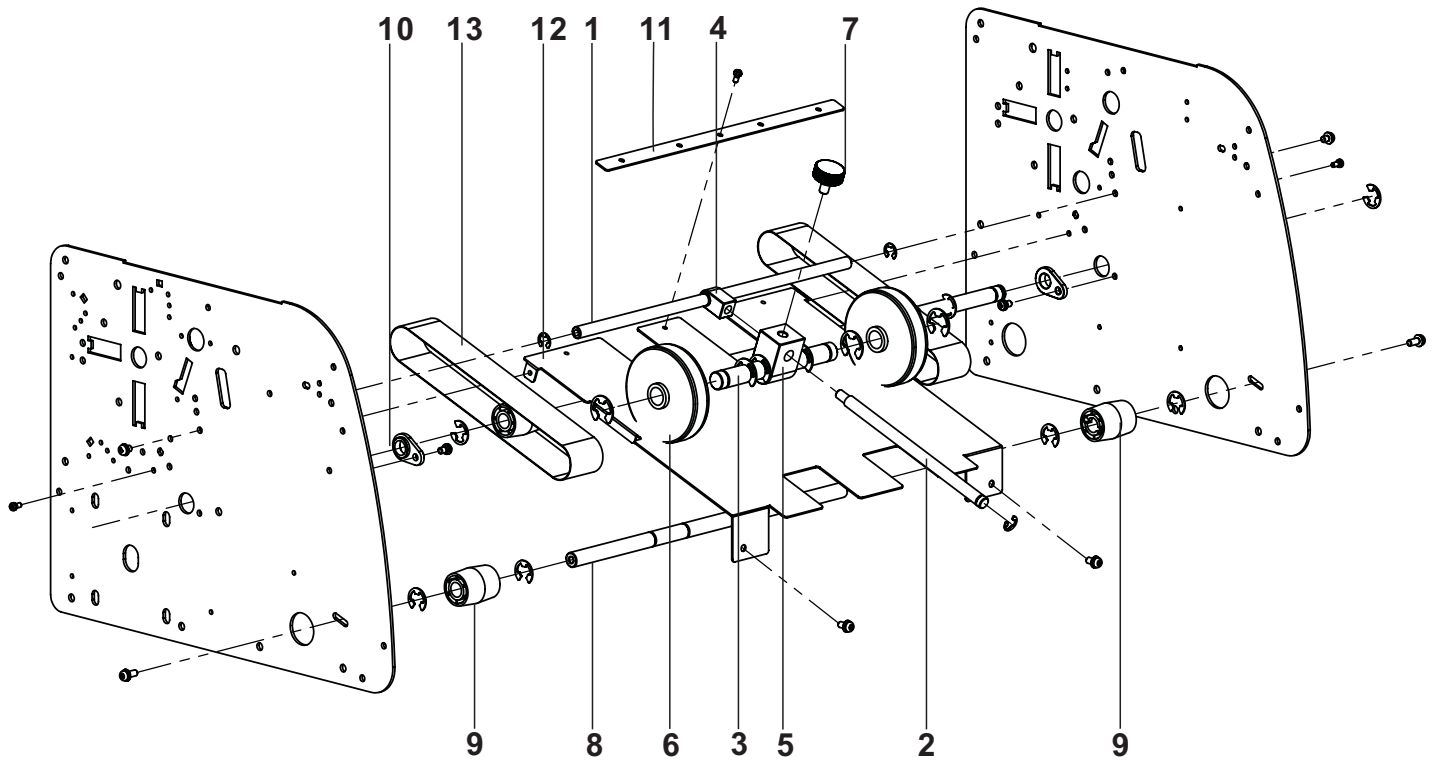

INDEX	PARTS NO.	DESCRIPTION	C.DESCRPTION	QTY	REMARK
1	HF230-501100	Horizontal shaft	横轴	1	
2	HF230-501400	Moving shaft	活动轴	1	
3	HF230-501500	Compression wheel shaft	压轮轴	1	
4	HF230-501200	Guide block 1	活动快1	1	
5	HF230-501300	Guide block 2	活动快2	1	
6	HF280-50902	Press roller	压纸轮	2	
7	HF230-501600	Lock screw	锁紧螺钉	1	
8	HF230-503100	Secondary stacker shaft	排纸副轴	1	
9	96V-J2490	Roller	滚轮	4	
10	995-B3181	Bearing	轴套	2	
11	HF230-402300	Locking piece	固定条	1	
12	HF230-504000	Receiving plate	接纸板	1	
13	HF230-509000	Flat belt	平皮带	2	

10. EJECTION SECTION

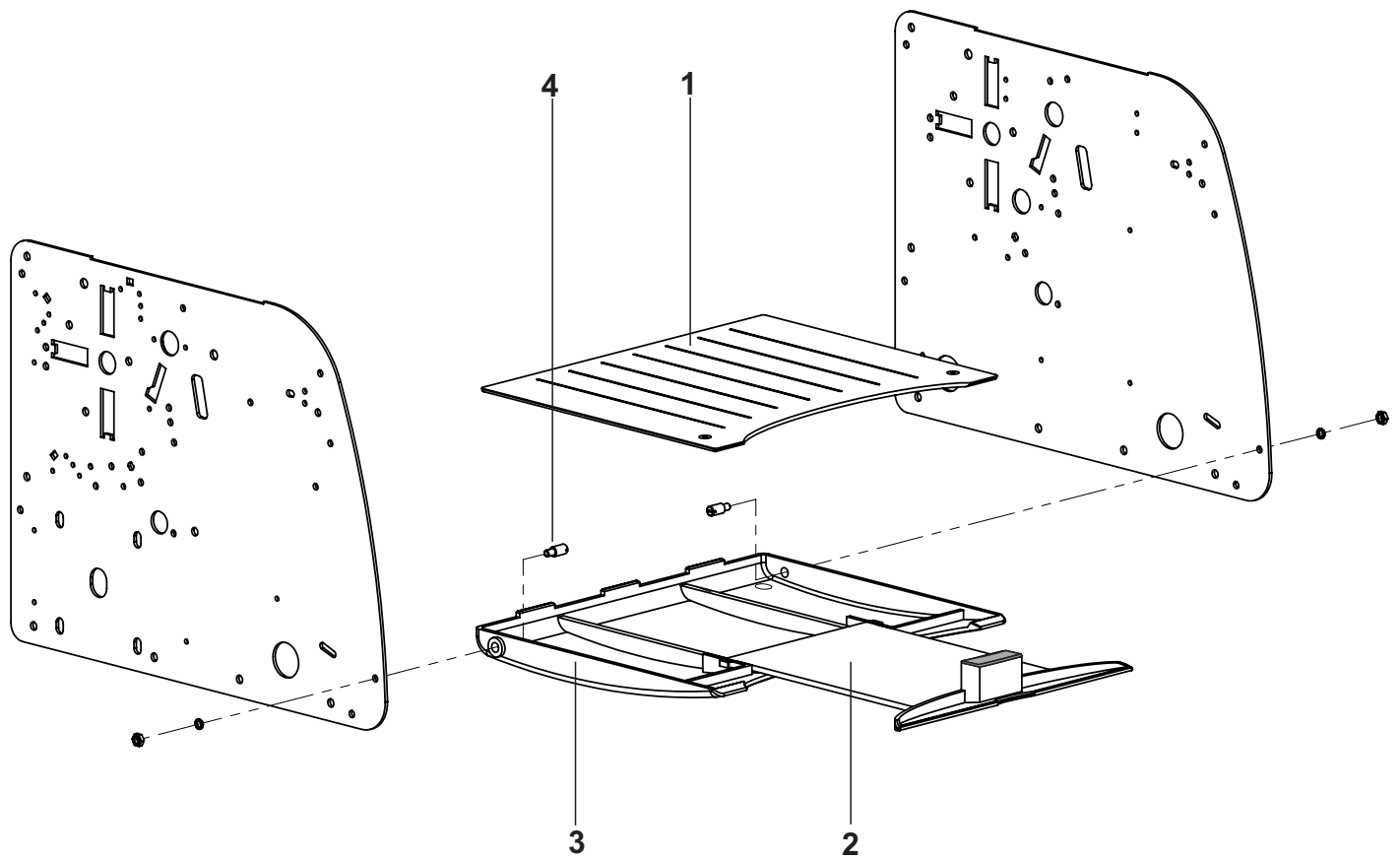

INDEX	PARTS NO.	DESCRIPTION	C.DESCRPTION	QTY	REMARK
1	HF230-601100	Upper receiver plate	接纸上板	1	
2	HF230-602000	Draw-out plate	抽板组件	1	
3	HF230-601300	Lower receiver plate	接纸下板	1	
4	HF230-107000	Pillar	挂钉	2	

11. CONTROL PANEL SECTION

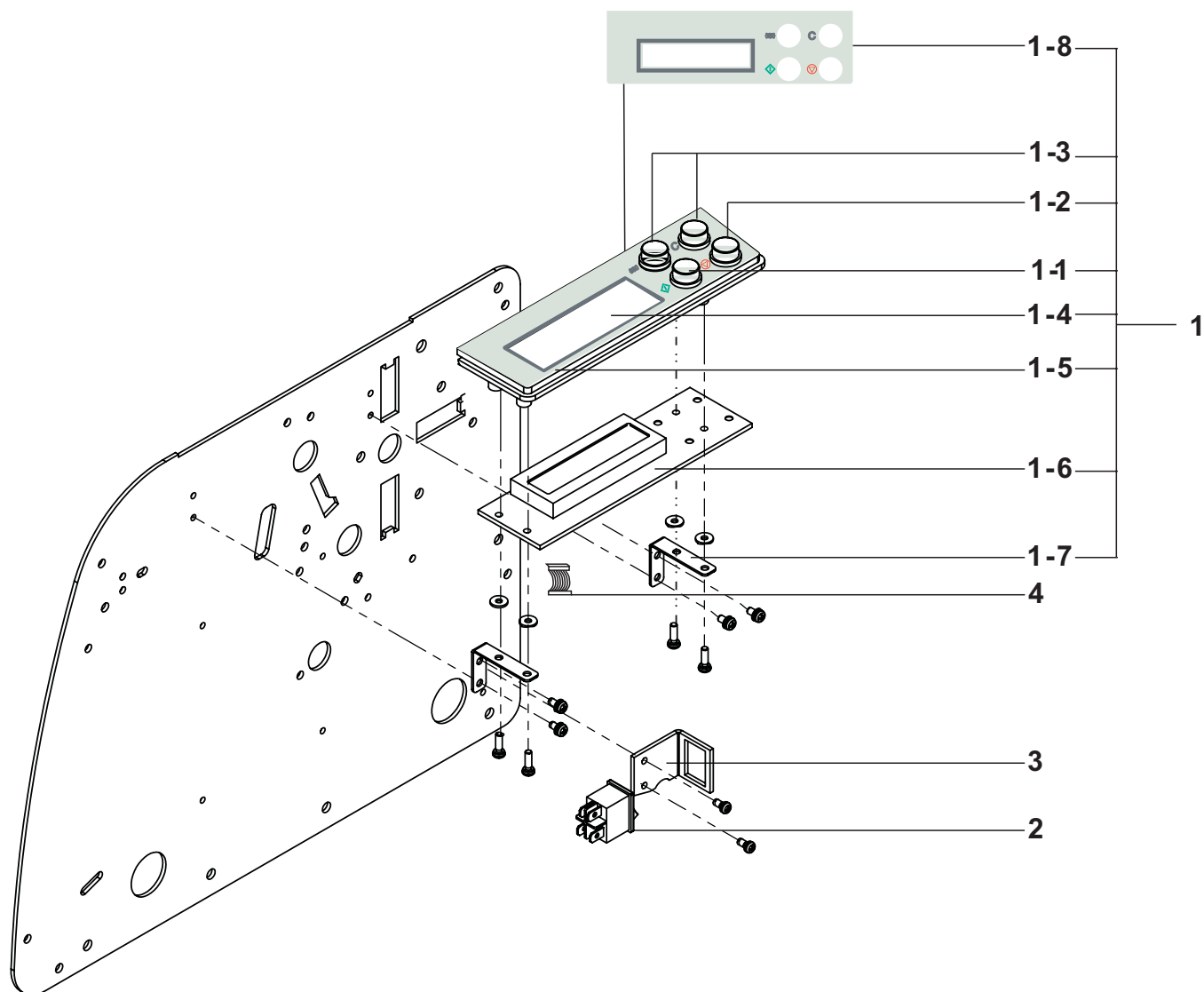

INDEX	PARTS NO.	DESCRIPTION	C.DESCRPTION	QTY	REMARK
1	HF230-705000	Control panel unit	操作面板组件	1	Part 1-1 to 1-8 are not for sell separately. They have to be purchased in a set HF230-705000.
1-1	HF230-760000	Button 3	按键3	1	
1-2	HF230-750000	Button 2	按键2	1	
1-3	HF230-740000	Button 1	按键1	2	
1-4	HF230-705200	Transparent cover plate	面板透明板	1	
1-5	HF230-705300	Operation panel	操作面板	1	
1-6	HF230-903000	Control panel PCB unit	操作控制板	1	
1-7	HF230-705100	Control panel holder	控制板支架	2	
1-8	HF230-810030	Panel instruction label	操作面板标签	1	
2	HDB-27	Power switch	电源开关	1	
3	HF230-712000	Power switch bracket	电源开关安装板	1	
4	HF230-920900	Flat cable	排线组件	1	

12.CONTROL PANEL SECTION

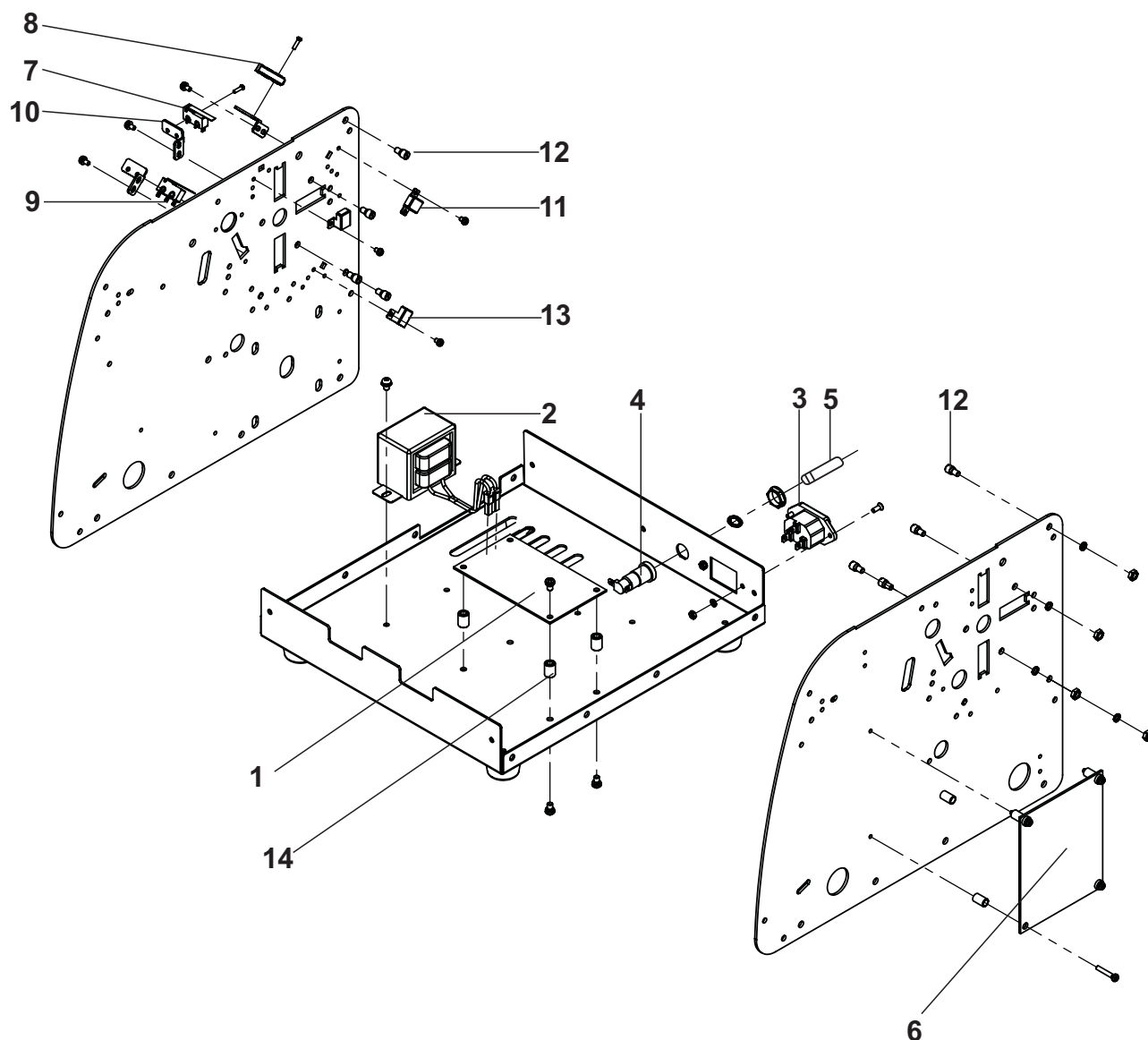

INDEX	PARTS NO.	DESCRIPTION	C.DESCRPTION	QTY	REMARK
1	HF230-901010	Power Supply board	电源板	1	
2	HF230-910310	Transformer (120V)	变压器	1	
3	HDB-04	Inlet	电源插座	1	
4	HF230-921000	Fuse holder	保险丝座	1	
5	DF777-94010	Fuse (4A)	保险丝管 (4A)	1	
6	HF230-902001	Main board	控制板	1	
7	HF230-910600	Micro switch	微动开关	1	
8	HF230-910500	Micro switch	微动开关	1	
9	HF230-910400	Micro switch	微动开关	1	
10	HF220D-11000	Micro switch upholding plate	微动开关支承架	3	
11	HF230-713000	Micro switch cover	罩壳	1	
12	HF230-402800	Locking pillar	固定柱	8	
13	HF230-714000	Micro switch cover	罩壳	2	
14	HBM32A-08500	Collar	导电螺母	4	

13.FRAME SUB FRAME SECTION

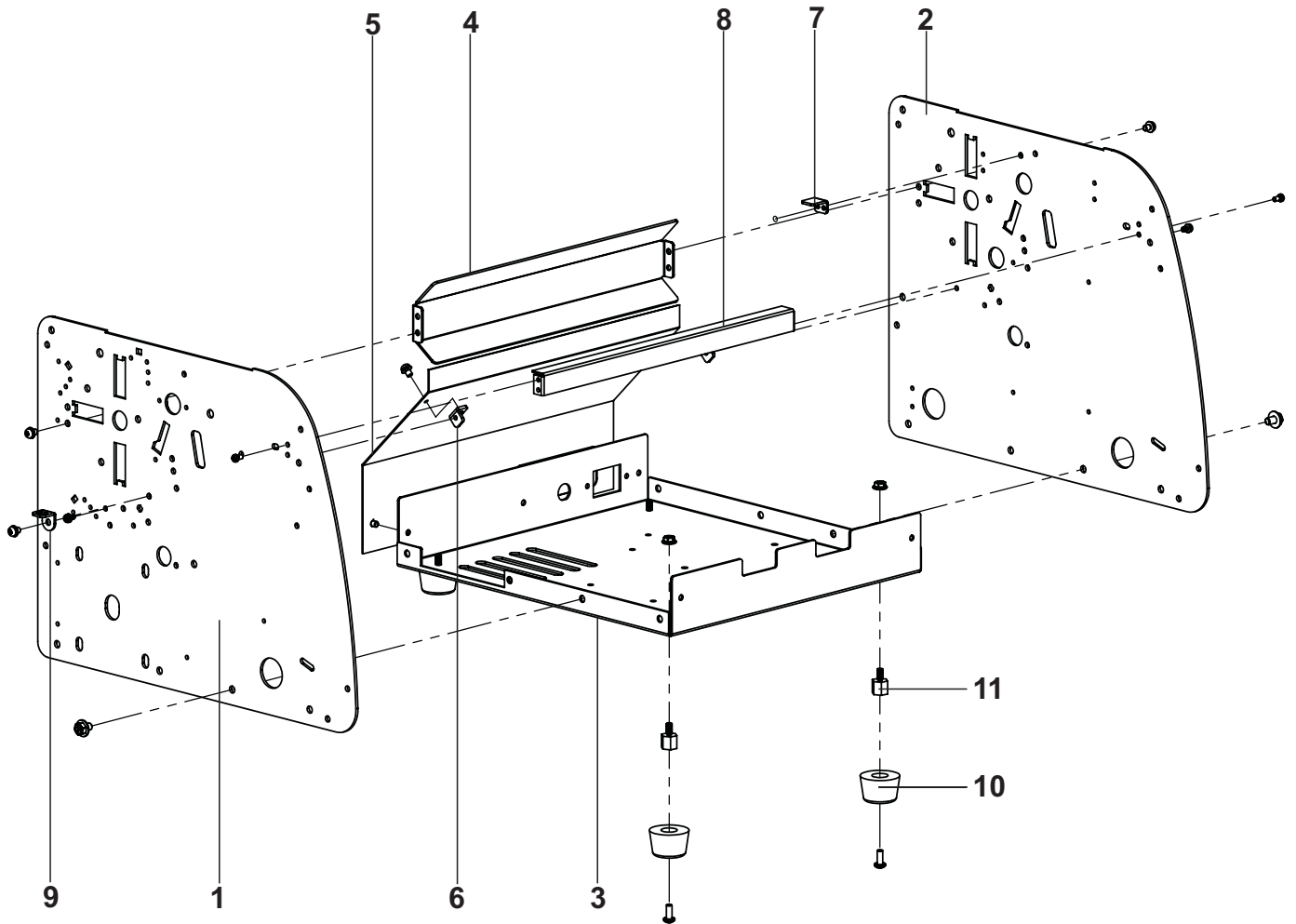

INDEX	PARTS NO.	DESCRIPTION	C.DESCRPTION	QTY	REMARK
1	HF230-703000	Frame (left)	左立板	1	
2	HF230-704000	Frame (right)	右立板	1	
3	HF230-707000	Bottom frame	底座	1	
4	HF230-708000	P-Roller protective cover	保护罩	1	
5	HF230-709000	Sealing Cover	封板	1	
6	HF230-711000	Upholding plate (for sealing cover)	封板固定板	2	
7	HF230-710000	Magnetic piece	吸铁片	1	
8	HF230-105000	Transitional connection board	过渡连接板	1	
9	HF220D-01000	Magnet	角铁	1	
10	HF220D-05700	Rubber foot base	橡胶底脚	4	
11	HF220D-04400	Rubber foot base pillar	橡胶底脚芯	4	

14. EXTERIOR

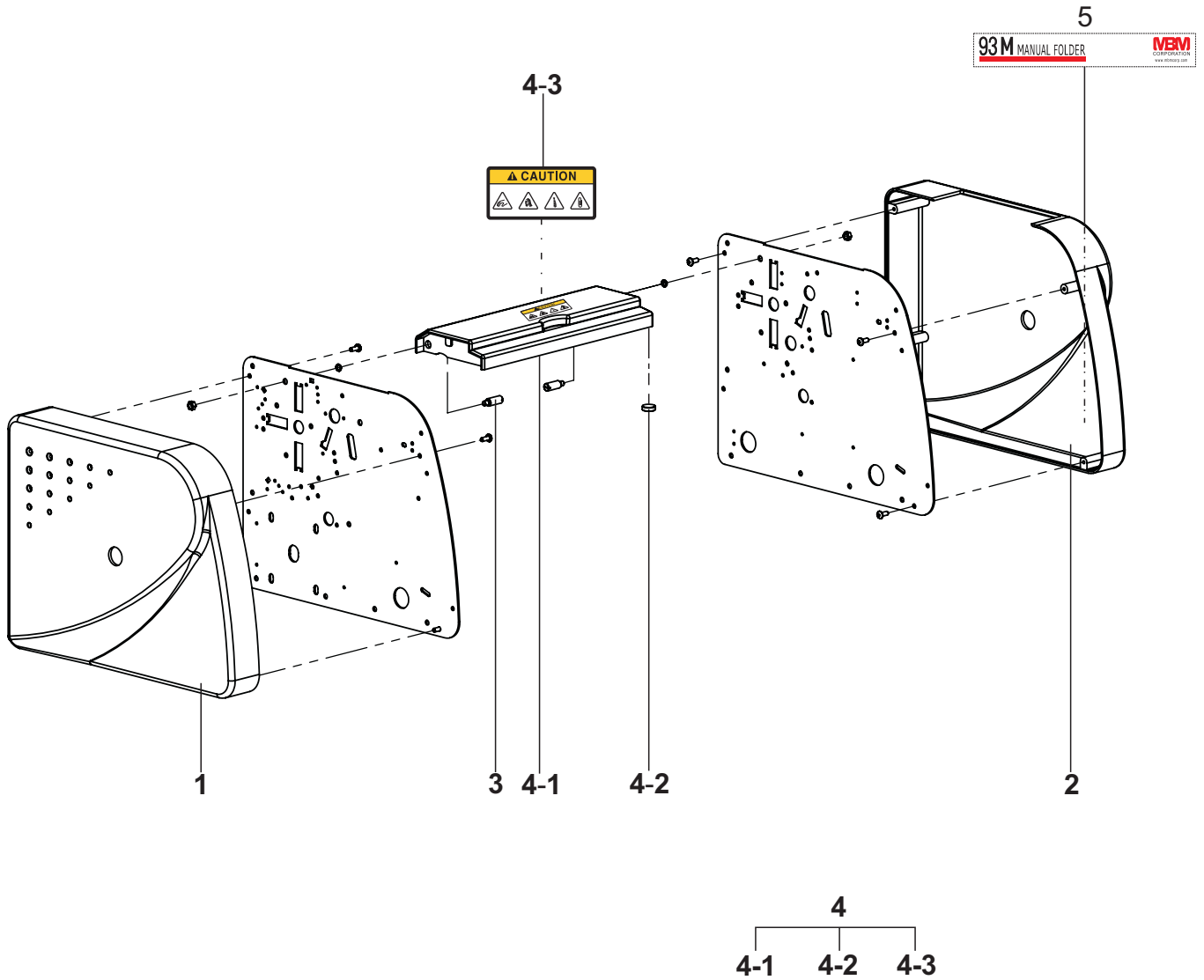

INDEX	PARTS NO.	DESCRIPTION	C.DESCRPTION	QTY	REMARK
1	HF230-701100	Cover (left)	左边盖组件	1	
2	HF230-702100	Cover (right)	右边盖组件	1	
3	HF230-706100	Cover shaft	翻盖轴	2	
4	HF230-706210	Top cover assy	上翻盖组件	1	
4-1	HF230-706000	Top cover	上翻盖	1	Part 4-1 to 4-3 are not for sell separately. They have to be purchased in a set HF230-706210.
4-2	HF220D-06600	Manget	磁铁	1	
4-3	HF220D-08100	Warning label	入纸口注意标签	1	
5	HF230-830010	Brand plate	机型标签	1	

15. FIRST FOLDING PLATE SECTION

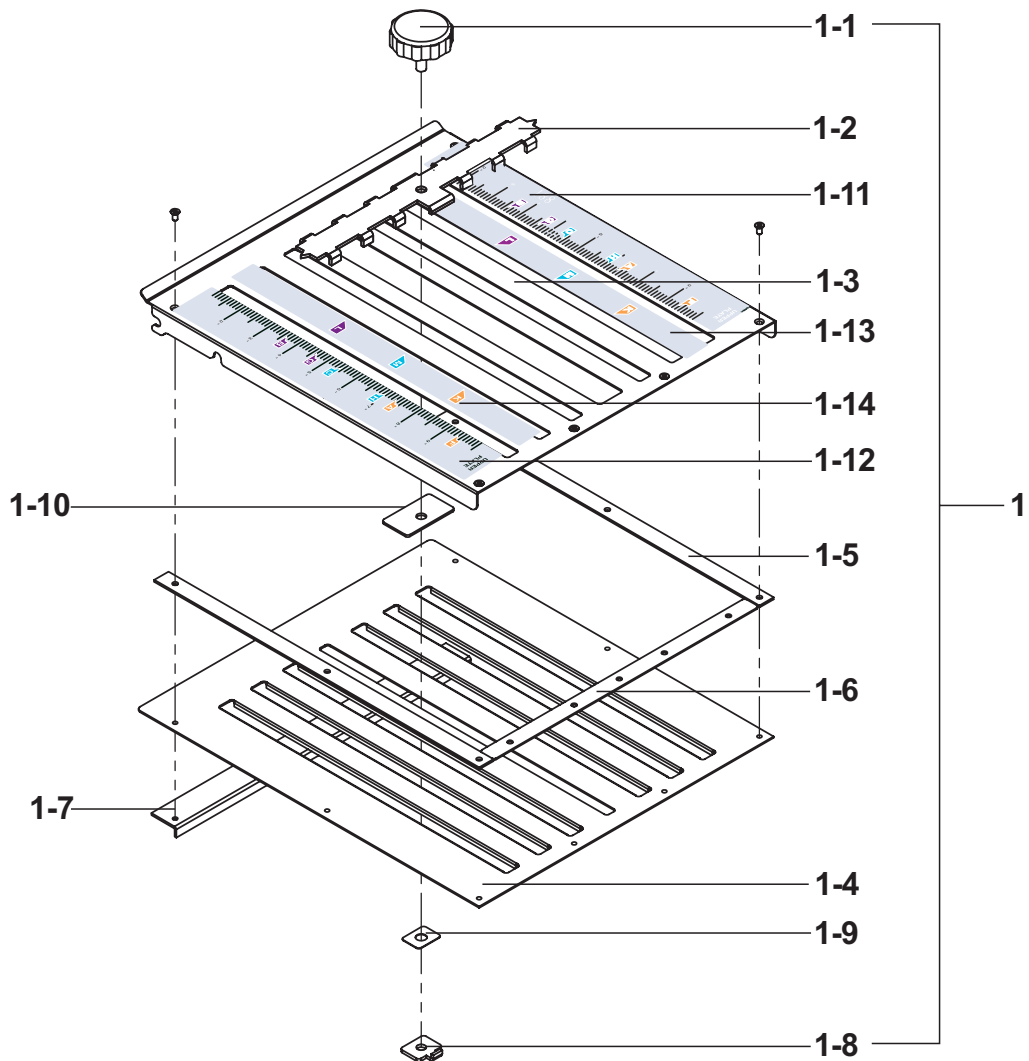

INDEX	PARTS NO.	DESCRIPTION	C.DESCRPTION	QTY	REMARK
1	HF230-402020	First folding plate assemble	一折板组件	1	
1-1	HF230-402700	Knob nut	锁紧手柄组件	1	Part 1-1 to 1-14 are not for sell separately. They have to be purchased in a set HF230-402020.
1-2	HF230-402500	Stopper	折页板挡纸条	1	
1-3	HF230-402100	First folding plate (upper)	一折板上板	1	
1-4	HF230-402400	First folding plate (lower)	一折板下板	1	
1-5	HF230-402200	Side separator	折板侧隔板	2	
1-6	HF230-402300	Locking piece	固定条	1	
1-7	HF230-402900	Strengthening plate	加强板	1	
1-8	HF230-402600	Locking plate	折页板锁紧板	1	
1-9	HF220D-04203	Anti-slip washer	防滑垫片	1	
1-10	HF230-403600	Separator	隔板	1	
1-11	HF230-830050	First folding plate label (left1)	折板标签 (左1)	1	
1-12	HF230-830060	First folding plate label (right1)	折板标签 (右1)	1	
1-13	HF230-830070	First folding plate label (left2)	折板标签 (左2)	1	
1-14	HF230-830080	First folding plate label (right2)	折板标签 (右2)	1	

16. SECOND FOLDING PLATE SECTION

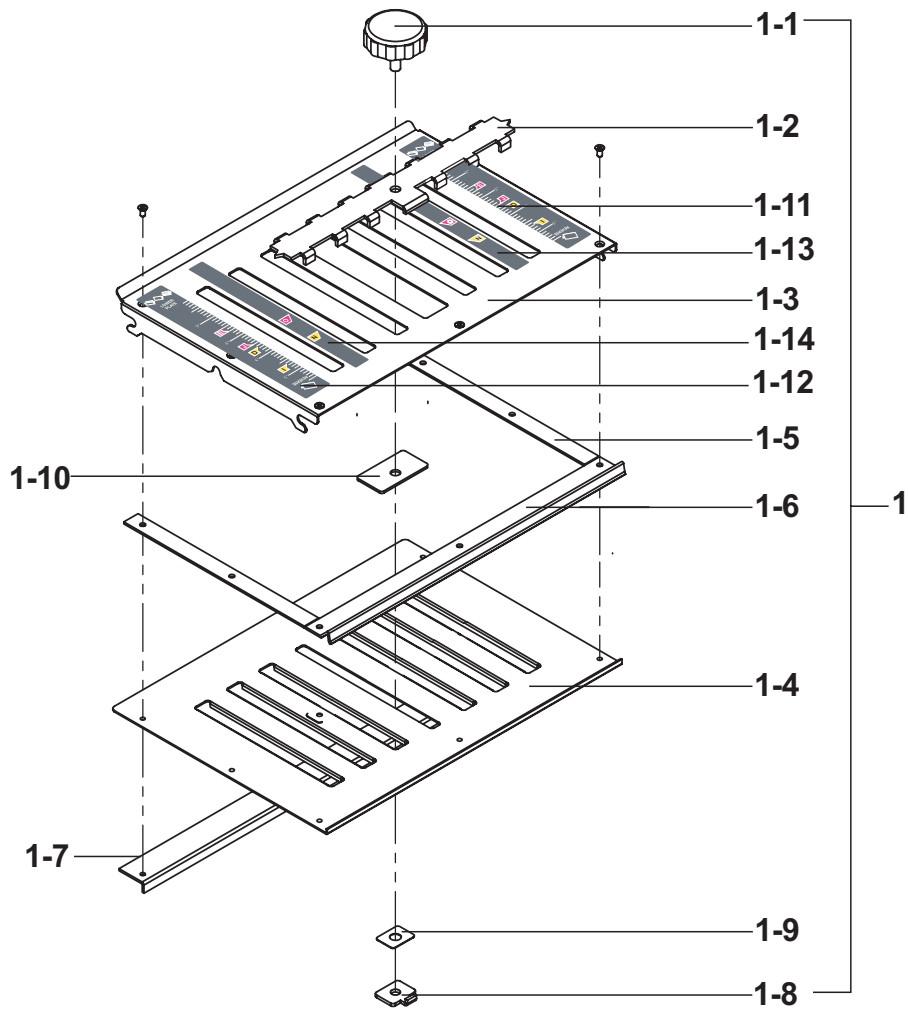

INDEX	PARTS NO.	DESCRIPTION	C.DESCRPTION	QTY	REMARK
1	HF230-403020	Second folding plate assemble	二折板组件	1	
1-1	HF230-402700	Knob nut	锁紧手柄组件	1	Part 1-1 to 1-14 are not for sell separately. They have to be purchased in a set HF230-403020.
1-2	HF230-402500	Stopper	折页板挡纸条	1	
1-3	HF230-403100	Second folding plate (upper)	二折板上板	1	
1-4	HF230-403300	Second folding plate (lower)	二折板下板	1	
1-5	HF230-403200	Side separator	折板侧隔板	2	
1-6	HF230-403400	Switching plate	切换板	1	
1-7	HF230-402900	Strengthening plate	加强板	1	
1-8	HF230-402600	Locking plate	折页板锁紧板	1	
1-9	HF220D-04203	Anti-slip washer	防滑垫片	1	
1-10	HF230-403600	Separator	隔板	1	
1-11	HF230-830100	Second folding plate label(right1)	二折板标签 (右1)	1	
1-12	HF230-830090	Second folding plate label(left1)	二折板标签 (左1)	1	
1-13	HF230-830120	Second folding plate label(right2)	二折板标签 (右2)	1	
1-14	HF230-830110	Second folding plate label(left2)	二折板标签 (左2)	1	

17. WIRE CONNECTOR SECTION

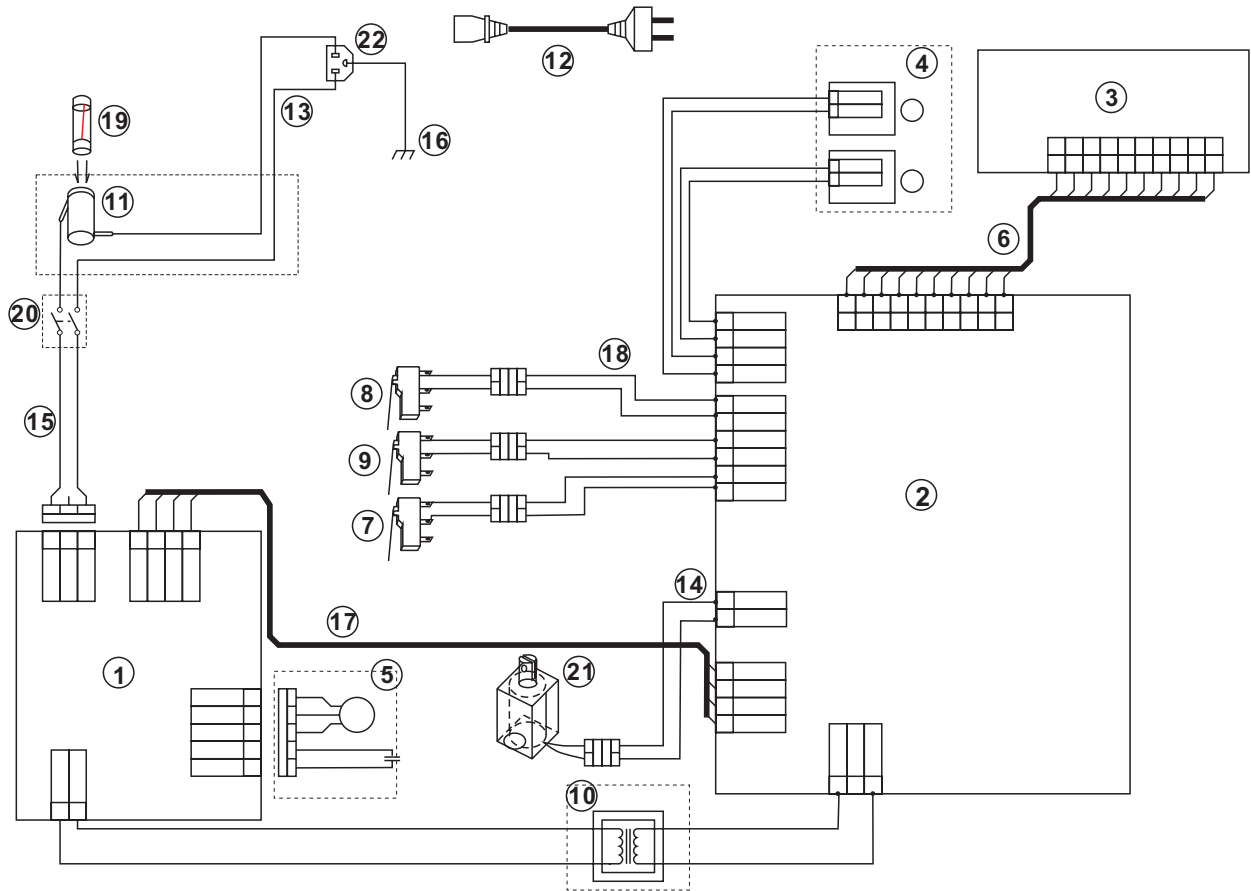

INDEX	PARTS NO.	DESCRIPTION	C.DESCRPTION	QTY	REMARK
1	HF230-901010	Power supply board	电源板	1	
2	HF230-902001	Main board	控制板	1	
3	HF230-903000	Control panel PCB unit	操作面板	1	
4	HF230-921100	Ejection light sensor	出纸光电组件	1	
5	HF230-910110	AC Motor unit (120V)	交流电机组件	1	
6	HF230-920900	Flat Cable	排线组件	1	
7	HF230-910600	Micro switch	顶盖微动开关	1	
8	HF230-910400	Micro switch	二折纸板微动开关	1	
9	HF230-910500	Micro switch	一折纸板微动开关	1	
10	HF230-910310	Transformer	变压器组件	1	
11	HF230-921000	Fuse holder (120V)	保险管座组件	1	
12	96V-H0830	Electric wire	电源线	1	
13	HF230-920200	Electric plug wire	蓝色连接线	1	
14	HF230-920700	Electromagnet wire	电磁铁连接线	1	
15	HF230-920800	Electric switch wire	电源板与电源开关连接线	1	
16	HF230-920100	Ground wire	接地线	1	
17	HF230-920300	Circuit board and control board wire	控制板电源板连接线	1	
18	HF230-920600	Mobility switch wire	控制板与微动开关连接线	1	
19	DF777-94010	Fuse (4A)	保险管	1	
20	HDB-27	Power Switch	电源开关	1	
21	HDB-01	Solenoid	电磁铁	1	
22	HDB-04	Inlet	电源线座	1	

18. INDEX

PARTS NO.	PAGES	INDEX	PARTS NO.	PAGES	INDEX
HF220D-00500	1	1	HF230-203000	6	7
HF220D-00704	1	5-6	HF230-204000	6	8
HF220D-00705	1	5-5	HF230-205000	6	1
HF220D-00706	1	5-4	HF230-206000	5	7
HF220D-00900	1	4	HF230-207000	7	1
HF220D-01000	13	9	HF230-301100	3	3
HF220D-01300	3	4	HF230-301300	3	2
HF220D-01301	3	4-3	HF230-301500	4	8
HF220D-01302	3	5	HF230-301600	4	5
HF220D-01303	3	4-2	HF230-301700	4	7
HF220D-01304	3	4-1	HF230-402020	15	1
HF220D-01305	3	4-5	HF230-402100	15	1-3
HF220D-01306	3	4-6	HF230-402200	15	1-5
HF220D-01903	4	6	HF230-402300	15	1-6
HF220D-032000	5	4		9	11
HF220D-03300	5	6	HF230-402400	15	1-4
HF220D-03310	5	5	HF230-402500	15	1-2
HF220D-035001	5	2		16	1-2
HF220D-04203	15	1-9	HF230-402600	15	1-8
	16	1-9		16	1-8
HF220D-04400	13	11	HF230-402700	15	1-1
HF220D-05700	13	10		16	1-1
HF220D-06600	14	4-2	HF230-402800	4	4
HF220D-08100	14	4-3		12	12
HF220D-11000	12	10	HF230-402900	15	1-7
HF220D-192000	7	2-4		16	1-7
HF220D-195001	7	1-2	HF230-403020	16	1
HF220D-209030	3	4-4	HF230-403100	16	1-3
HF230-101000	1	5	HF230-403200	16	1-5
HF230-101100	1	5-2	HF230-403300	16	1-4
HF230-101200	1	5-1	HF230-403400	16	1-6
HF230-101300	1	5-3	HF230-403600	15	1-10
HF230-101400	1	5-9		16	1-10
HF230-101500	1	5-7	HF230-501100	9	1
HF230-101600	1	5-8	HF230-501200	9	4
HF230-102100	4	1	HF230-501300	9	5
HF230-102200	4	2	HF230-501400	9	2
HF230-102300	4	3	HF230-501500	9	3
HF230-103000	1	2	HF230-501600	9	7
HF230-104000	1	3	HF230-502000	6	10
HF230-105000	13	8	HF230-503100	9	8
HF230-106020	2	1	HF230-504000	9	12
HF230-106100	2	1-4	HF230-506100	8	5
HF230-106200	2	1-3	HF230-506200	8	1
HF230-106300	2	1-2	HF230-506300	8	3
HF230-107000	2	2	HF230-506400	8	4
	10	4	HF230-507100	8	6
HF230-201000	5	1	HF230-507200	8	2

19. INDEX

PARTS NO.	PAGES	INDEX	PARTS NO.	PAGES	INDEX
HF230-509000	9	13	HF230-910310	17	10
HF230-601100	10	1		12	2
HF230-601300	10	3	HF230-910400	17	8
HF230-602000	10	2		12	9
HF230-701100	14	1	HF230-910500	17	9
HF230-702100	14	2		12	8
HF230-703000	13	1	HF230-910600	17	7
HF230-704000	13	2		12	7
HF230-705000	11	1	HF230-920100	17	16
HF230-705100	11	1-7	HF230-920200	17	13
HF230-705200	11	1-4	HF230-920300	17	17
HF230-705300	11	1-5	HF230-920600	17	18
HF230-706000	14	4-1	HF230-920700	17	14
HF230-706100	14	3	HF230-920800	17	15
HF230-706210	14	4	HF230-920900	17	6
HF230-707000	13	3		11	4
HF230-708000	13	4	HF230-921000	17	11
HF230-709000	13	5		12	4
HF230-710000	13	7	HF230-921100	17	4
HF230-711000	13	6		8	7
HF230-712000	11	3	HF280-50902	9	6
HF230-713000	12	11	HBM32A-08500	12	14
HF230-714000	12	13	T00010	5	3
HF230-720000	6	9	941-A0031	6	5
HF230-730000	6	2	941-A0181	7	2-1
HF230-740000	11	1-3	96V-11110	7	2-2
HF230-750000	11	1-2	96V-A1101	7	2
HF230-760000	11	1-1	96V-A1140	7	2-5
HF230-810030	11	1-8	96V-A1170	7	2-6
HF230-830010	14	5	96V-A1190	7	2-3
HF230-830040	2	1-1	96V-A1261	3	1
HF230-830050	15	1-11	96V-A1400	7	1-5
HF230-830060	15	1-12	96V-A2052	6	3
HF230-830070	15	1-13	96V-A2170	6	4
HF230-830080	15	1-14	96V-H0830	17	12
HF230-830090	16	1-12	96V-J2490	9	9
HF230-830100	16	1-11	96V-L0310	7	1-1
HF230-830110	16	1-14	96V-L0330	7	1-4
HF230-830120	16	1-13	995-B3181	9	10
HF230-901010	17	1	HDB-01	7	1-3
	12	1		17	21
HF230-902001	12	6	HDB-04	17	22
	17	2		12	3
HF230-903000	17	3	HDB-27	17	20
	11	1-6		11	2
HF230-910110	6	6	DF777-94010	17	19
	17	5		12	5