

CR-50XP Cornerounder®

USER'S MANUAL

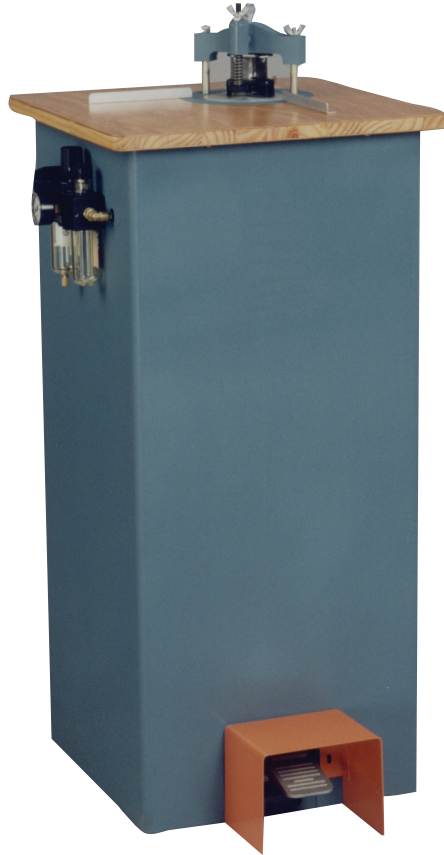

ProSource Packaging, Inc.  
14911 Stuebner Airline Suite A  
Houston, TX 77069  
800-203-0233  
www.Machine-Solution.com

*Before operating this equipment, please read these instructions completely and keep these operating instructions for future reference.*

Serial Number: \_\_\_\_\_  
Date of Purchase: \_\_\_\_\_  
Dealer: \_\_\_\_\_  
Address: \_\_\_\_\_  
\_\_\_\_\_  
Telephone Number: \_\_\_\_\_

# Table Of Contents

## 1 - Introduction

- 1.1 Your New CR-50XP..... Page 01
- 1.2 Shipping Damage Inspection..... Page 01

## 2 - Safety

- 2.1 Safety Instructions..... Page 02
- 2.2 Warning Labels..... Page 03

## 3 - Setting Up Your Machine

- 3.1 Loose Items Inventory..... Page 03
- 3.2 Installing the Leveling Feet..... Page 04
- 3.3 Foot Pedal Guard..... Page 04
- 3.4 Preparing the Regulator System..... Page 05
- 3.5 Cutting Unit Installation (Standard & Special Sizes)..... Page 06
- 3.6 Cutting Unit Installation (Large Sizes).. Page 07
- 3.7 Adjusting the Side Guides..... Page 07
- 3.8 Adjusting the Pressure Foot..... Page 08

## 4 - Operation

- 4.1 Corner Rounding Operation..... Page 08
- 4.2 Cutting Unit Capacities..... Page 08
- 4.3 Chip Removal..... Page 08

## 5 - Maintenance

- 5.1 Safety..... Page 09
- 5.2 Annual Lubrication..... Page 09

## 6 - Parts Diagram

- 6.1 Parts Diagram..... Page 09
- 6.2 Parts List..... Page 10

# 1 - Introduction

## 1.1 - Your New CR-50XP

- Thank you for your purchase of the CR-50XP Cornerounder®.
- We ask that you take a moment to fill in the serial number and other information on the front cover of the manual. Please keep this manual as a reference for future use.
- For parts and service, please contact the Lassco-Wizer Dealer from whom you purchased the machine. If you require assistance in locating a Lassco-Wizer Dealer please contact our customer service department at 585-436-1934. Please have the model of your machine and the serial number when you call.
- If you wish to write to us, send correspondence to:

Lassco-Wizer  
Attn: Customer Service  
485 Hague Street  
Rochester, NY 14606

## 1.2 - Shipping Damage Inspection

- Remove the machine from the carton and inspect for any shipping damage. If any damage is present, report the damage to the carrier immediately; failure to do so may void any warranties.

## 2 - Safety

### 2.1 - Safety Instructions

- All operators must read and understand the Users Manual including all safety instructions before using this equipment. Failure to fully understand the safety instructions can result in personal injury. If after reading the manual you are still uncertain about use, please contact the dealer from whom you purchased the machine for assistance. If you need contact information for a Service Technician nearest you please call 585-436-1934.
- SAFETY OF THIS EQUIPMENT IS THE RESPONSIBILITY OF THE USER(S).
- Please read and follow all warning labels on your machine.
- Keep hands clear while operating machine.
- ALWAYS USE SAFETY GLASSES. Everyday eyeglasses only have impact resistant lenses, they are NOT safety glasses.
- KEEP GUARDS IN PLACE and in working order.
- Always disconnect the power before servicing this machine. Service should only be performed by a QUALIFIED TECHNICIAN.
- THIS MACHINE IS DESIGNED FOR ONE PERSON OPERATION. Never operate the machine with more than one person.
- KEEP CHILDREN AWAY. All visitors should be kept a safe distance from the work area.
- USE RIGHT MACHINE. Don't force tool or attachment to do a job for which it was not designed.
- MAINTAIN MACHINE WITH CARE. Keep tools sharp and clean for best and safest performance. Follow instructions for lubricating and changing accessories.
- DISCONNECT MACHINE when changing accessories, such as cutting units.
- REDUCE THE RISK OF UNINTENTIONAL STARTING. Make sure the air valve shutoff is in the off position when the machine is not in use.
- NEVER STAND ON MACHINE. Serious injury could occur if the machine is tipped.
- CHECK DAMAGED PARTS. Before further use of the machine, a guard or other part that is damaged should be carefully checked to determine that it will operate properly and perform its intended function--check for alignment of moving parts, binding of moving parts, breakage of parts, mounting, and any other conditions that may affect its operation. A guard or other part that is damaged should be properly repair or replaced.
- NEVER LEAVE MACHINE RUNNING UNATTENDED. TURN POWER OFF. Don't leave machine until it comes to a complete stop.

## 2 - Safety

### 2.2 - Warning Labels

#### English



#### ⚠ WARNING

Read and understand operator's manual and all other safety instructions before using this equipment



#### ⚠ WARNING

**Moving parts can crush and cut**  
**Keep hands clear while operating machine.**



#### ⚠ WARNING

Risk of eye injury.  
Wear eye protection.

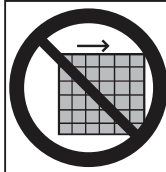

#### ⚠ WARNING

Risk of Injury.  
Do NOT operate without guards in place.

#### French

#### ⚠ AVERTISSEMENT

Lire et bien comprendre le manuel de l'opérateur avant d'utiliser cette machine.

Le fait de ne pas suivre les consignes d'utilisation peut entraîner des blessures graves ou endommager l'équipement.

#### ⚠ AVERTISSEMENT

Les pièces mobiles peuvent écraser et couper.

Éloignez les mains lorsque vous opérez cette machine.

#### ⚠ AVERTISSEMENT

Risque de blessures aux yeux.

Protection des yeux nécessaire.

#### ⚠ AVERTISSEMENT

Faire attention de ne pas se blesser.

Ne pas utiliser cette machine sans la présence de tous les dispositifs de sécurité.

## 3 - Setting Up Your Machine

### 3.1 - Loose Items Inventory

- Please remove and inspect the following items:



Oil

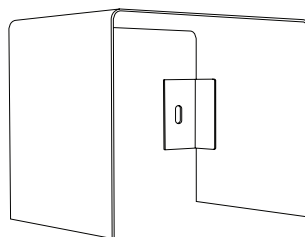

Foot Pedal Guard (1)

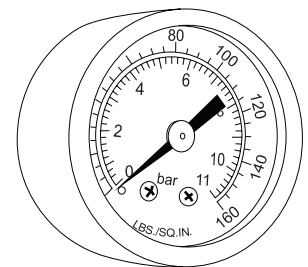

Pressure Gauge (1)

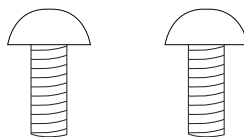

10-32 x 1/2" Button Head Socket Screw (2)



1/8" Hex Wrench (1)

## 3 - Setting Up Your Machine

### 3.2 - Installing the Leveling Feet

- 3.2.1** Set the machine down in its desired location and determine if the machine is level, making sure that it does NOT rock in any direction. If it does, determine which Leveling Feet need to be adjusted and whether they need to be adjusted up or down.
- 3.2.2** If adjustment is needed, start by loosening the four (4) nuts which are accessed through the rear of the machine.
- 3.2.3** Next adjust the four (4) Leveling Feet by screwing them clockwise to raise the or counter-clockwise to lower. After each adjustment set the machine down completely to verify that the machine no longer rocks. Continue adjustment as needed until the machine sits securely in place. Tighten the four (4) nuts down to secure the position of the Leveling Feet.

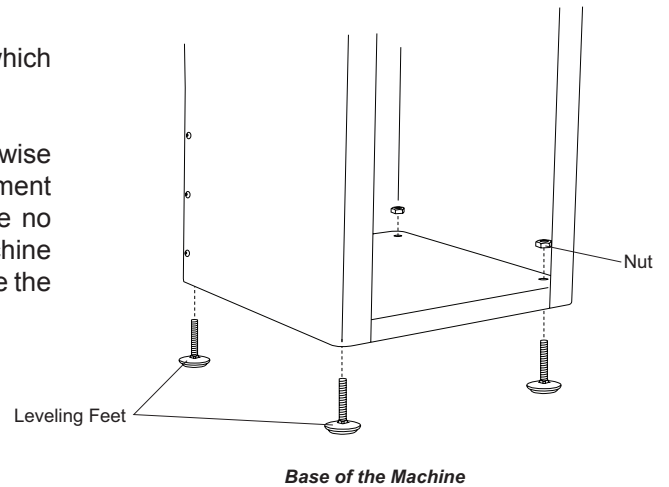

### 3.3 - Foot Pedal Guard

- 3.3.1** Attach the orange Foot Pedal Guard to the base of the machine so that it covers the Foot Pedal protecting it from accidental activation. Use the two 10-32 x 1/2" Button Head Socket Screws. Tighten down using the 1/8" Hex Wrench (provided).

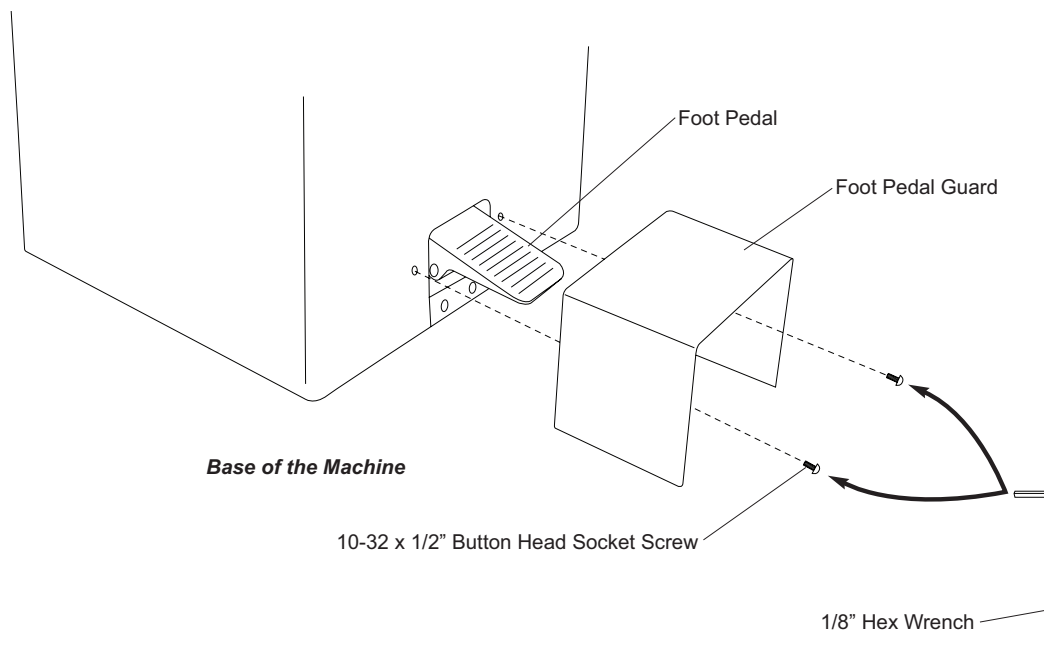

# 3 - Setting Up Your Machine

## 3.4 - Preparing the Regulator System

- 3.4.1** Attach the Pressure Gauge to the Air Regulator by screwing it in as shown below. The threads on the Pressure Gauge have Teflon tape attached to prevent air leakage. Tighten down using a 7/16" opened ended wrench (not provided).
- 3.4.2** Add the provided oil to the Airline Lubricator located on the side of the machine by removing the slotted Set Screw and filling the Lubricator so as to cover the bottom of the brass Oil Intake Tube visible inside the globe as shown below. Replace the Set Screw making sure the Set Screw Washer is positioned correctly.
- 3.4.3** Install the Airline into the Air Valve Shutoff on the side of the machine screwing it tightly in place.
- 3.4.4** Rotate the Air Valve Shutoff counter-clockwise to allow air passage into the machine. To stop the passage of air to the machine rotate the Air Valve Shutoff clockwise.
- 3.4.5** Adjust the Pressure Gauge to 80 PSI for normal performance. Adjust by either turning the Pressure Adjustment Knob counter clockwise to raise the PSI or clockwise to lower the PSI.

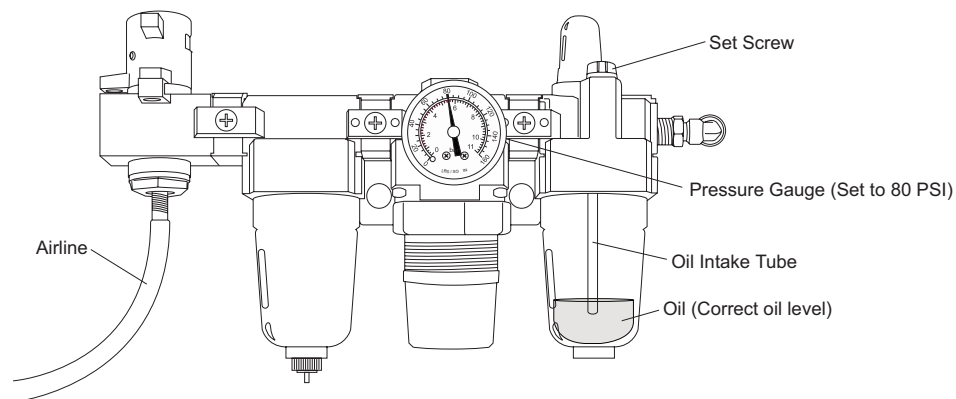
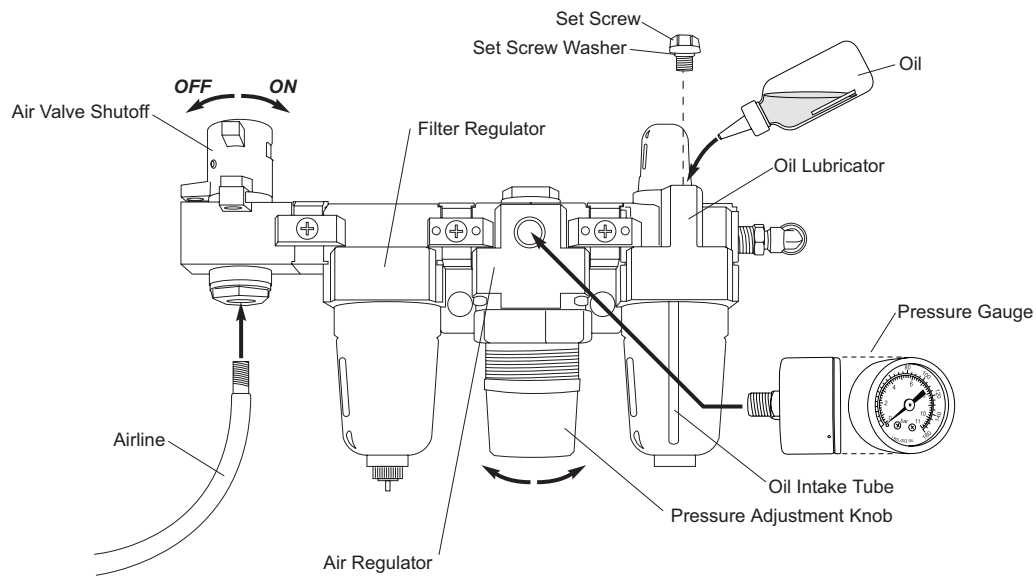

## 3 - Setting Up Your Machine

### 3.5 - Cutting Unit Installation (Standard & Special Sizes)

- 3.5.1** Loosen the Top Yoke Wing Nut (50-34) on the right hand side of the Top Yoke (50-15) and swing the Top Yoke toward you to obtain access to the Cutting Unit Cavity in the Table Ring Casting (50-14).
- 3.5.2** Making sure the Adapter Hold Down Tab (50-11) is not in the way, insert the Adapter Plate (50-26) into the Table Ring Casting. Make sure that the Adapter Plate Rotation Tab (50-12) slips under the Table Ring Casting into its designated groove to prevent unwanted rotation of the Adapter Plate. Turn the Adapter Hold Down Tab so that it locks the Adapter Plate into place.
- 3.5.3** Insert the Cutting Unit into the Adapter Plate.
- 3.5.4** Swing the Top Yoke back into its original position making sure it is fully engaged in the Yoke Slide Rod (50-04). Tighten down the Top Yoke Wing Nut to secure in place.
- 3.5.5** Depress the Foot Pedal to engage the cutting cycle making sure to check that the Cutting Unit is working properly.

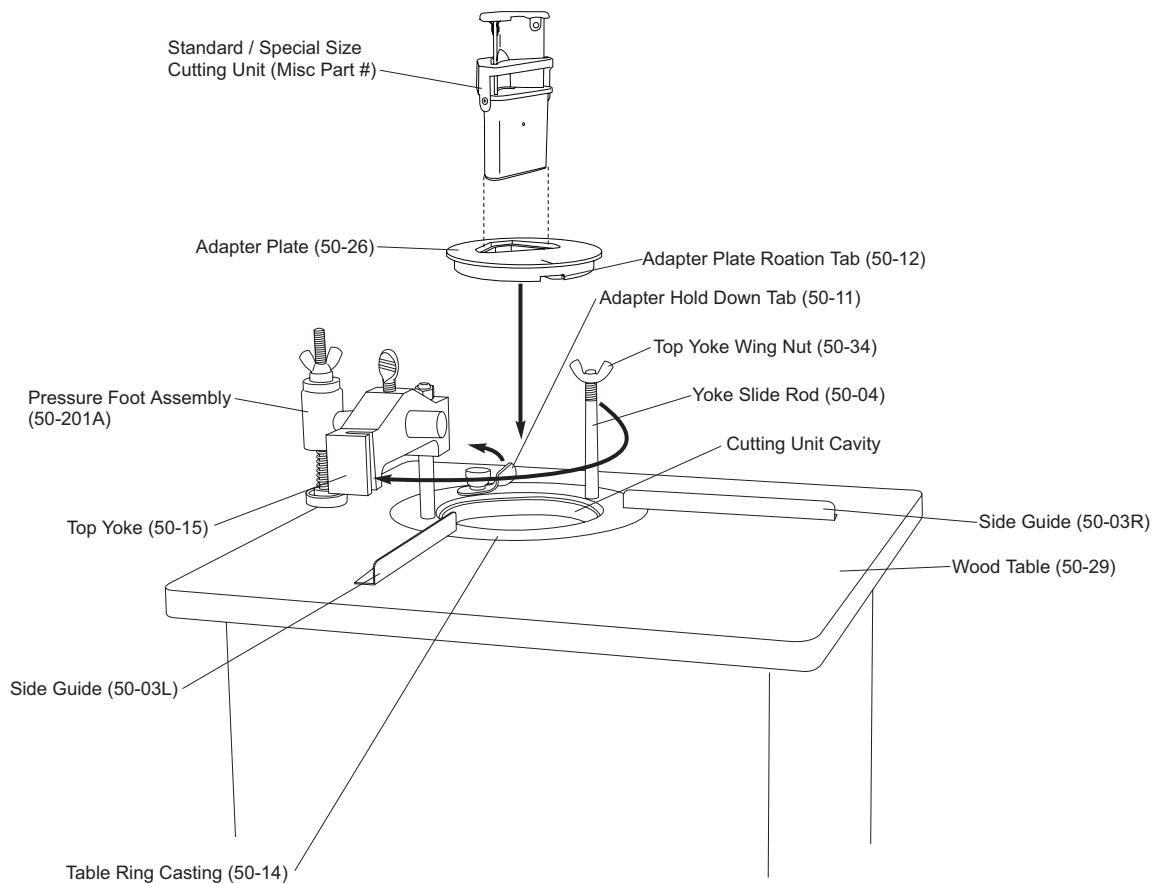

## 3 - Setting Up Your Machine

### 3.6 - Cutting Unit Installation (Large Sizes)

- 3.6.1** Loosen the Top Yoke Wing Nut (50-34) on the right hand side of the Top Yoke (50-15) and swing the Top Yoke as shown to obtain access to the Cutting Unit Cavity in the Table Ring Casting (50-14).
- 3.6.2** Make sure the Adapter Plate has been removed.
- 3.6.3** Insert the Large Size Cutting Unit into the Table Ring Casting by tilting and seating it and pushing back and down until it is secure in place. Make sure the Rotation Tab on the Cutting Unit slips under the Table Ring Casting into its designated groove to prevent unwanted rotation of the Cutting Unit. Turn the Adapter Hold Down Tab (50-11) so that it locks the Cutting Unit into place.
- 3.6.4** Swing the Top Yoke back into its original position making sure it is fully engaged in the Yoke Slide Rod (50-04). Tighten down the Top Yoke Wing Nut to secure in place.
- 3.6.5** Depress the Foot Pedal to engage the cutting cycle making sure to check that the Cutting Unit is working properly.

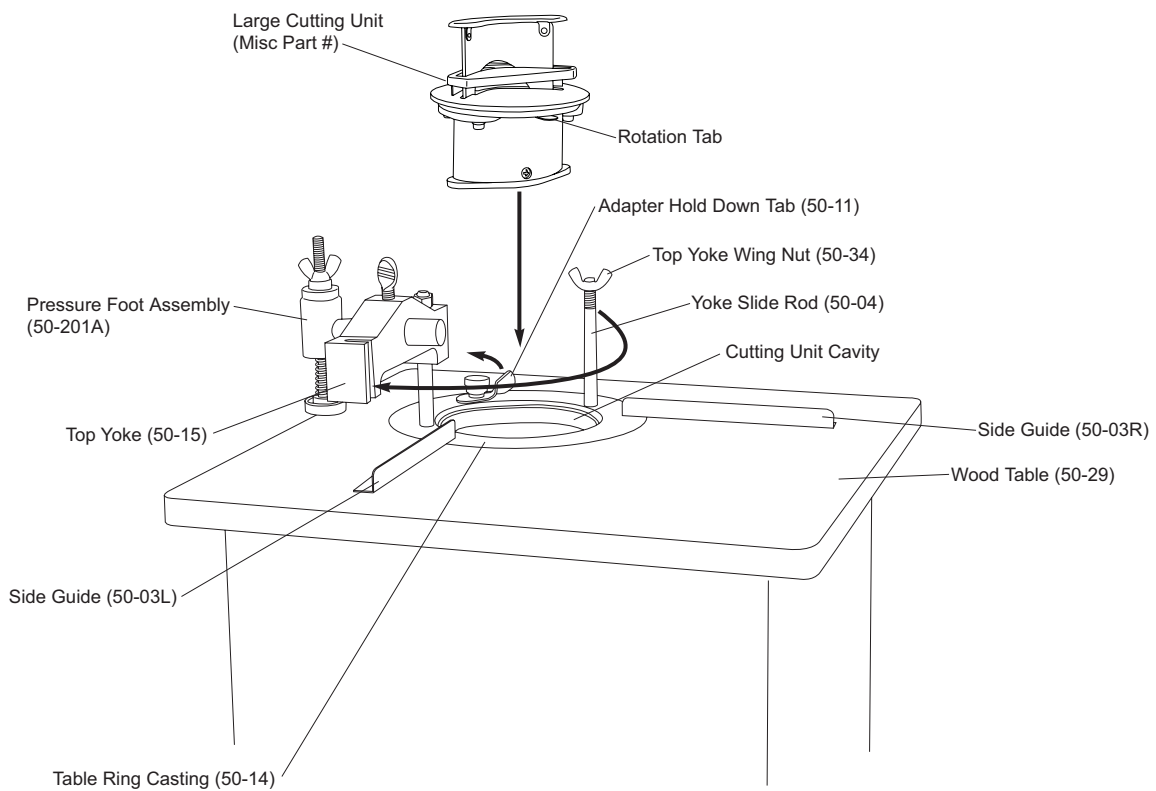

### 3.7 - Adjusting the Side Guides

- 3.7.1** Adjust the Side Guides so that they are square with the cutting unit you are using. We recommend using a right angle tool (not included).
- 3.7.2** Slide the tool into the corner of the Cutting Unit making sure it is square with both edges of the Knife.
- 3.7.3** Loosen the Screws on the Side Guides and adjust as needed. Re-tighten the screws to secure the Side Guides.



## 3 - Setting Up Your Machine

### 3.8 - Adjusting the Pressure Foot

**3.8.1** To adjust horizontally (depending on the size of the Cutting Unit) loosen the center Thumb Screw on the Top Yoke, adjust in or out until the Pressure Foot clears the black guard on the Cutting Unit. Secure by tightening the center Wing Nut down.

**3.8.2** Adjust the Pressure Foot clamping pressure to accommodate different product heights. Loosen the Wing Nut on the top of the Pressure Foot. Tighten the Hex Nut underneath to increase the pressure. Loosen the Hex Nut to decrease pressure. When the pressure is set as desired tighten down the Wing Nut to lock the tension in place.

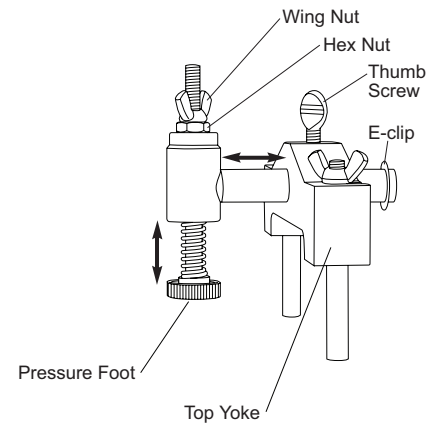

## 4 - Operation

### 4.1 - Corner Rounding Operation

**4.1.1** Place the product you are cutting onto the Wooden Top Plate and push it into the corner aligning it with the Two Side guides.

**4.1.2** Press down firmly to prevent the product from sliding out of the corner.

**4.1.3** Depress the Foot Pedal once to engage the cutting cycle. The Pressure Foot will come down helping to secure the product in place. The Cutting Unit will come down.

**4.1.4** Release the Foot Pedal once the cutting unit has come down all the way. The cutting unit will return to its upright position. This machine does not cycle.

**4.1.5** Repeat as needed

**4.1.6** It may be necessary to adjust the Side Guides to compensate for variation in the cutting unit geometry, especially when changing from a Standard / Special Size Cutting Unit to a Large Size Cutting Unit.

### 4.2 - Cutting Unit Capacities

**4.2.1** Standard / Special Size Cutting Units:

These size Cutting Units were designed to handle up to a 1/2" stack of paper. They will also cut many other materials such as plastics, cardboard, celluloid, leather, wood, and even light soft metals. With heavier materials, however, best results may be obtained if only one or a few pieces are cut at a time.

**4.1.2** Large Size Cutting Units:

These size Cutting Units were designed to handle up to a 1/8" stack of paper. They will also cut many other materials such as plastics, cardboard, celluloid, leather, and wood. With heavier materials, however, best results may be obtained if only one or a few pieces are cut at a time.

### 4.3 - Chip Removal

**4.3.1** Place a waste bin or a disposable basket underneath the Chip Chute on the rear of the machine. This will catch the chips as they are cut and slide down the Chip Chute. Empty as needed.

## 5 - Maintenance

### 5.1 - Safety



**ALWAYS TURN OFF AND DISCONNECT THE AIR SUPPLY BEFORE PERFORMING MAINTENANCE ON THIS MACHINE. MAINTENANCE SHOULD ONLY BE PERFORMED BY A QUALIFIED TECHNICIAN.**



**KEEP HANDS CLEAR WHILE PERFORMING MAINTENANCE ON THIS MACHINE. MOVING PARTS CAN CRUSH AND CUT.**

### 5.2 - Annual Lubrication

**5.2.1** Lightly oil the two Yoke Slide Rods where they enter the adapter ring approximately every two weeks or as needed depending on use.

**5.2.2** Maintain, as needed, an oil level in the Oil Lubricator so that oil is covering the bottom of the Pickup Tube inside the globe. If oil appears around the Foot Valve, the lubrication rate is excessive and can be diminished by turning the knob on top of the Lubricator clockwise.

## 6 - Parts Diagram

### 6.1 - Parts Diagram

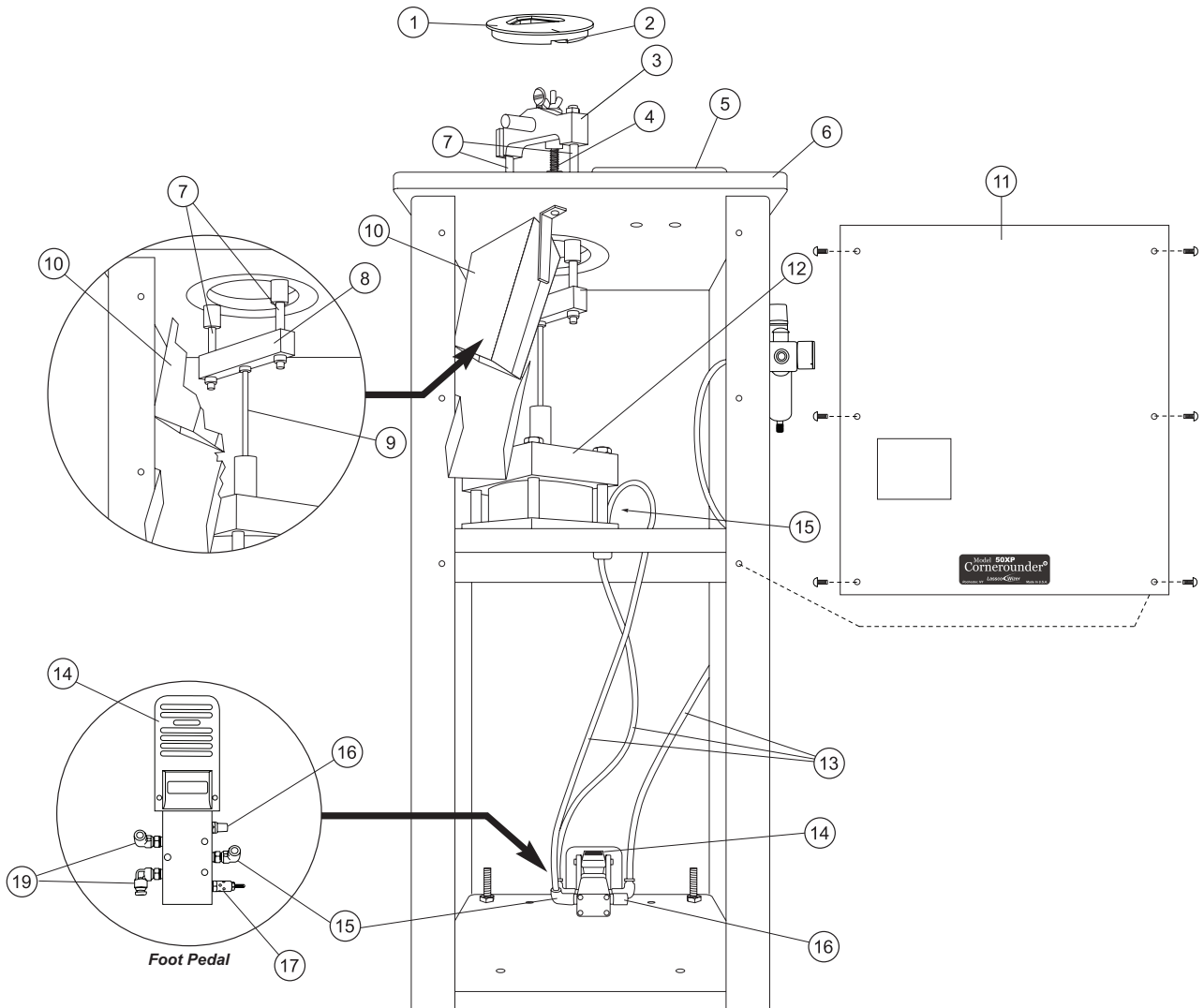

# 6 - Parts Diagram

## 6.2 - Parts List

- ① 50-26: Adapter Plate
- ② 50-12: Adapter Plate Rotation Tab
- ③ 50-15: Top Yoke
- ④ 50-201A: Pressure Foot Assembly
- ⑤ 50-03L: Left Paper Guide (50-03R: Right Paper Guide Not Shown)
- ⑥ 50P-80: Wood Table
- ⑦ 50-04: Yoke Slide Rods
- ⑧ 50P-41: Bottom Yoke
- ⑨ 50XP-2010: Pull Rod
- ⑩ 50XP-600AB: Upper Chip Chute
- ⑪ 50XP-40: Back
- ⑫ 50XP-2006: Air Cylinder
- ⑬ FMP2-2007: Air Hose (x3)
- ⑭ FMP2-2004: Foot Pedal
- ⑮ FMP2-2010: Elbow (x2 not shown)
- ⑯ FMP2-2002: Stationary Muffler
- ⑰ FMP2-2003: Adjustable Muffler