

CR-50 Cornerounder<sup>®</sup>

## USERS MANUAL



ProSource Packaging, Inc.  
14911 Stuebner Airline Suite A  
Houston, TX 77069  
800-203-0233  
[www.Machine-Solution.com](http://www.Machine-Solution.com)

*Before operating this equipment, please read these instructions completely and keep these operating instructions for future reference.*

Serial Number: \_\_\_\_\_  
Date of Purchase: \_\_\_\_\_  
Dealer: \_\_\_\_\_  
Address: \_\_\_\_\_  
\_\_\_\_\_  
\_\_\_\_\_  
Telephone Number: \_\_\_\_\_

# Introduction

## Introduction

- Thank you for your purchase of the CR-50 Cornerounder®.
- We ask that you take a moment to fill in the serial number and other information on the front cover of this manual. Please keep this manual as a reference for future use.
- For parts and service please contact the Lassco-Wizer Dealer from whom you purchased the machine. If you require assistance in locating a Lassco-Wizer Dealer please contact our customer service department at 585-436-1934. Please have the model of your machine and the serial number when you call.
- If you wish to write to us please contact us at:

Lassco-Wizer  
485 Hague Street  
Rochester, NY 14606

## Shipping Damage Inspection

- Remove the machine from the carton and inspect for any shipping damage. If any damage is present, report the damage to the carrier immediately. Failure to do so may void any warranties.

# Introduction

## Safety Instructions

- All operators must read and understand the Users Manual and all other safety instructions before using this equipment. Failure to fully understand the safety instructions can result in personal injury. If after reading the manual you are still uncertain about use, please contact the dealer from whom you purchased the machine for assistance. If you need contact information for a Service Technician nearest you please call 585-436-1934.
- Safety of this equipment is the responsibility of the users.
- This machine is designed for one person operation. Never operate the machine with more than one person.
- Do not place fingers into the Cutting Unit. Do not remove the safety guard on the Cutting Unit.
- Do not place hands or fingers underneath the pressure foot.

# Setting Up Your Machine

## Leveling Your Machine

- Place the machine in its desired location and level it by loosening the Nut on one of the Leveling feet. Turn the Leveling Foot counterclockwise to lower it or clockwise to raise it. When it is positioned as desired tighten down the Nut. Repeat as needed with the remaining Leveling Feet.

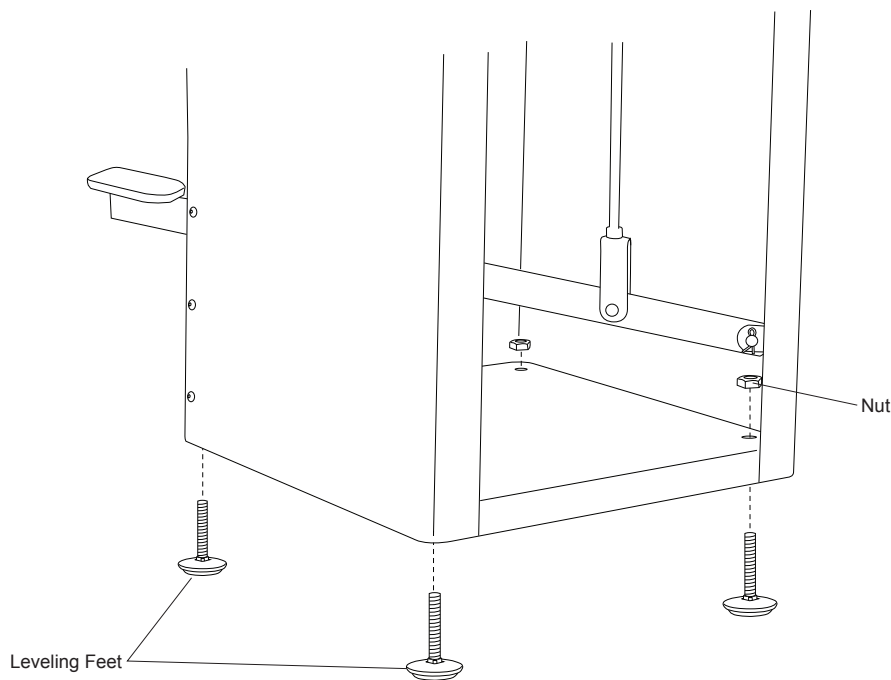

*Base of the Machine*

## Cutting Unit Installation (Special & Standard Sizes)

1. Loosen the Top Yoke Wing Nut (50-34) on the right hand side of the Top Yoke (50-15) and swing the Top Yoke toward you to obtain access to the Cutting Unit Cavity in the Table Ring Casting (50-14).
2. Making sure the Adapter Hold Down Tab (50-11) is not in the way, insert the Adapter Plate (50-26) into the Table Ring Casting. Make sure that the Adapter Plate Rotation Tab (50-12) slips under the Table Ring Casting into its designated groove to prevent unwanted rotation of the Adapter Plate. Turn the Adapter Hold Down Tab so that it locks the Adapter Plate into place.
3. Insert the Cutting Unit into the Adapter Plate.
4. Swing the Top Yoke back into its original position making sure it is fully engaged in the Yoke Slide Rod (50-04). Tighten down the Top Yoke Wing Nut to secure in place.
5. Depress the Foot Pedal to engage the cutting cycle making sure to check that the Cutting Unit is working properly.

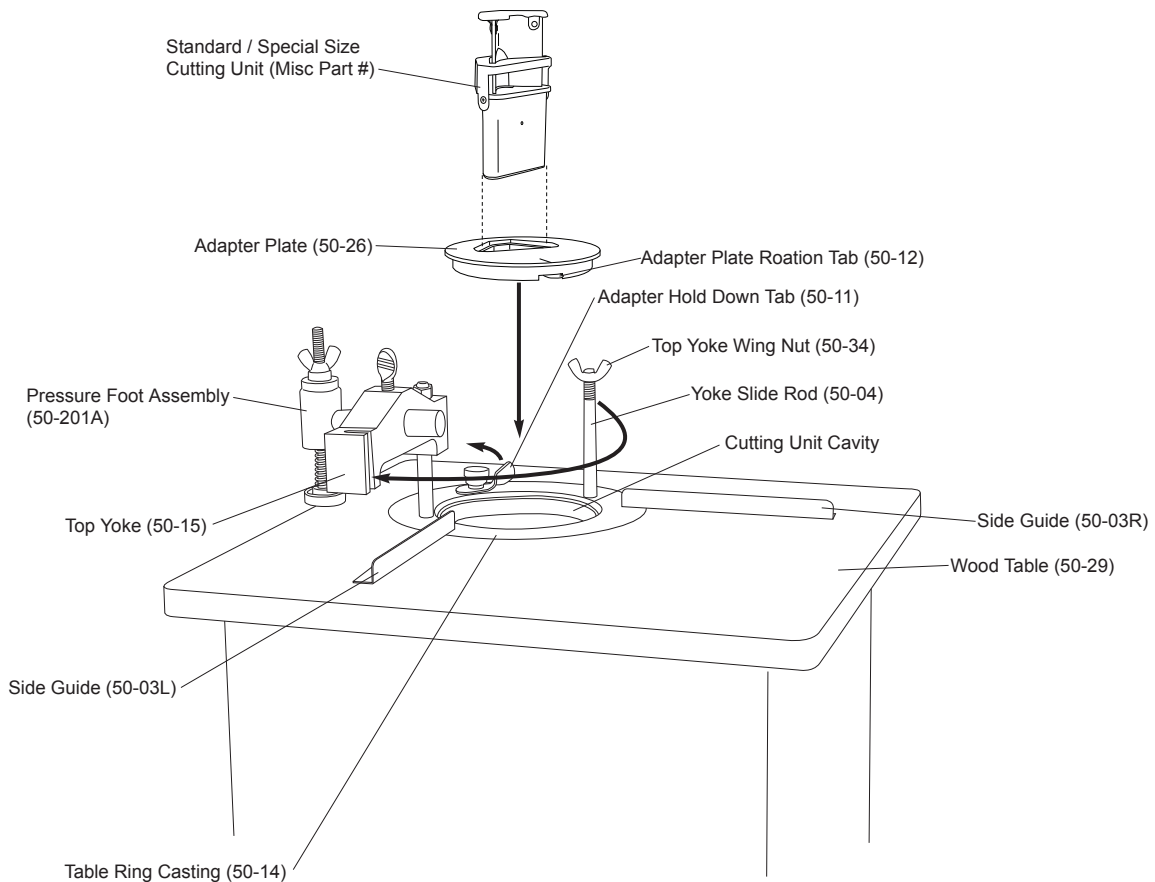

## Cutting Unit Installation (Large Sizes)

1. Loosen the Top Yoke Wing Nut (50-34) on the right hand side of the Top Yoke (50-15) and swing the Top Yoke as shown to obtain access to the Cutting Unit Cavity in the Table Ring Casting (50-14).
2. Make sure the Adapter Plate has been removed.
3. Insert the Large Size Cutting Unit into the Table Ring Casting by tilting and seating it and pushing back and down until it is secure in place. Make sure the Rotation Tab on the Cutting Unit slips under the Table Ring Casting into its designated groove to prevent unwanted rotation of the Cutting Unit. Turn the Adapter Hold Down Tab (50-11) so that it locks the Cutting Unit into place.
4. Swing the Top Yoke back into its original position making sure it is fully engaged in the Yoke Slide Rod (50-04). Tighten down the Top Yoke Wing Nut to secure in place.
5. Depress the Foot Pedal to engage the cutting cycle making sure to check that the Cutting Unit is working properly.

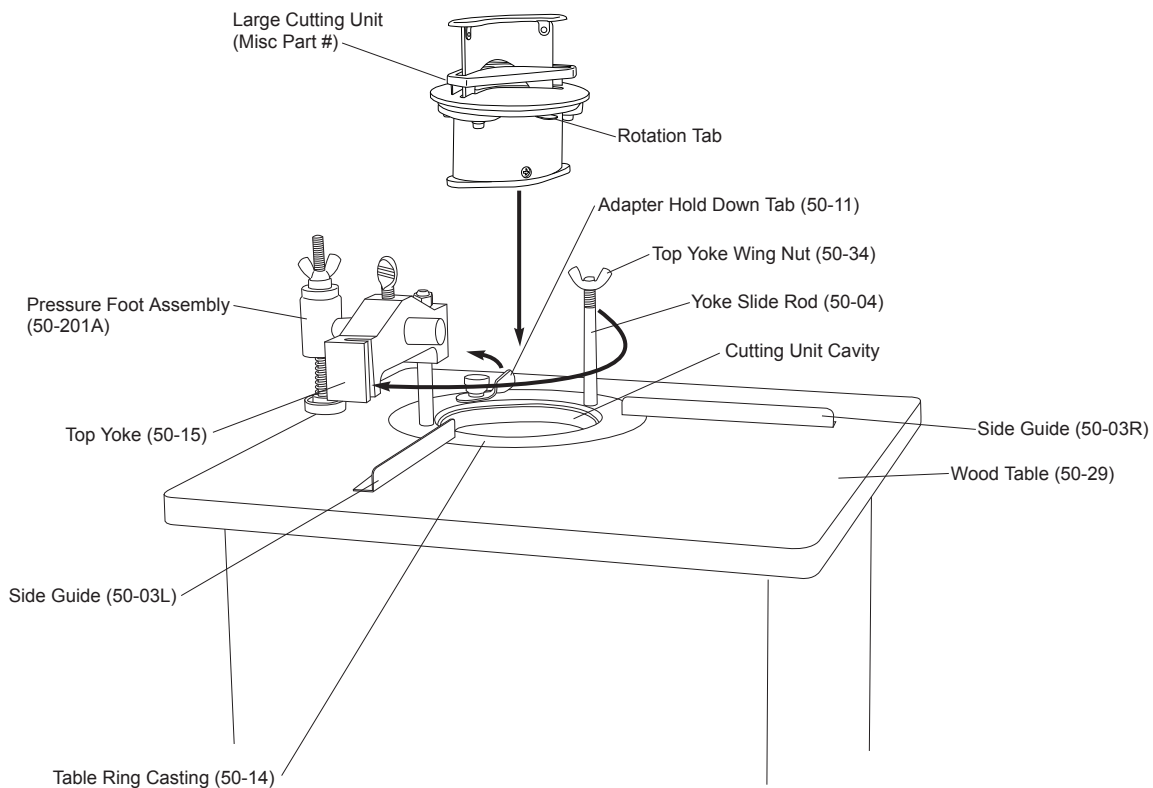

## Adjusting the Side Guides

- Adjust the Side Guides so that they are square with the cutting unit you are using. We recommend using a right angle tool (not included).
- Slide the tool into the corner of the Cutting Unit making sure it is square with both edges of the Knife.
- Loosen the Screws on the Side Guides and adjust as needed. Re-tighten the screws to secure the Side Guides.

## Pressure Foot Adjustment

- To adjust horizontally (depending on the size of the Cutting Unit) loosen the center Thumb Screw on the Top Yoke, adjust in or out until the Pressure Foot clears the black guard on the Cutting Unit. Secure by tightening the center Wing Nut down.
- Adjust the Pressure Foot clamping pressure to accommodate different product heights. Loosen the Wing Nut on the top of the Pressure Foot. Tighten the Hex Nut underneath to increase the pressure. Loosen the Hex Nut to decrease pressure. When the pressure is set as desired tighten down the Wing Nut to lock the tension in place.

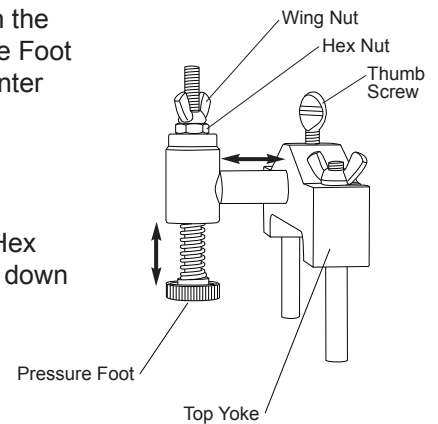

# Operating Instructions

## Corner Rounding Operation

- Place the product you are cutting onto the Wooden Top Plate and push it into the corner aligning it with the Two Side guides.
- Press down firmly to prevent the product from sliding out of the corner.
- Depress the Foot Pedal engaging the cutting cycle. The Pressure Foot will come down helping to secure the product in place.
- After the Cutting Unit has been depressed completely, raise the Foot Pedal bringing the Cutting Unit Blade and Pressure Foot back to its original position.
- Repeat as needed.

**Note:** It may be necessary to adjust the Side Guides to compensate for variation in the cutting unit geometry, especially when changing from a Standard / Special Size Cutting Unit to a Large Size Cutting Unit.

## Cutting Unit Capacities

- Standard / Special Size Cutting Units:  
These size Cutting Units were designed to handle up to a 1/2" stack of paper. They will also cut many other materials such as plastics, cardboard, celluloid, leather, wood, and even light soft metals. With heavier materials, however, best results may be obtained if only one or a few pieces are cut at a time.
- Large Size Cutting Units:  
These size Cutting Units were designed to handle up to a 1/8" stack of paper. They will also cut many other materials such as plastics, cardboard, celluloid, leather, and wood. With heavier materials, however, best results may be obtained if only one or a few pieces are cut at a time.

## Chip Removal

- The chips will fall onto the tray directly underneath the Wood Table. Remove them by hand by accessing the tray in the rear of the machine.

# Maintenance

## Standard Maintenance

- Lightly oil the two Yoke Slide Rods where they enter the adapter ring approximately every two weeks or as needed depending on use.

## Parts Diagrams

