

CR-177 Cornerounder[®]

USERS MANUAL



ProSource Packaging, Inc.
14911 Stuebner Airline Suite A
Houston, TX 77069
800-203-0233
www.Machine-Solution.com

*Before operating this equipment,
please read these instructions
completely and keep these operating
instructions for future reference.*

Serial Number: _____
Date of Purchase: _____
Dealer: _____
Address: _____



Telephone Number: _____

Safety Instructions

- Keep fingers away from the cutting area and blades when operating.
- Use caution when releasing the handle, be advised it is spring loaded.
- Do not use this machine to cut metal.

Loose Materials Inventory

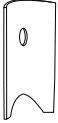
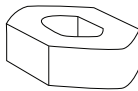
- Remove and inspect the following items:

Blade (2) 	Die (1) 	HEX-18: Hex Wrench 1/8" (1) 	HEX-316: Hex Wrench 3/16" (1) 
-----------------------------------------------------------------------------------------------	----------------------------------------------------------------------------------------------	---------------------------------------------------------------------------------------------------------------------	------------------------------------------------------------------------------------------------------------------------

Parts Diagram

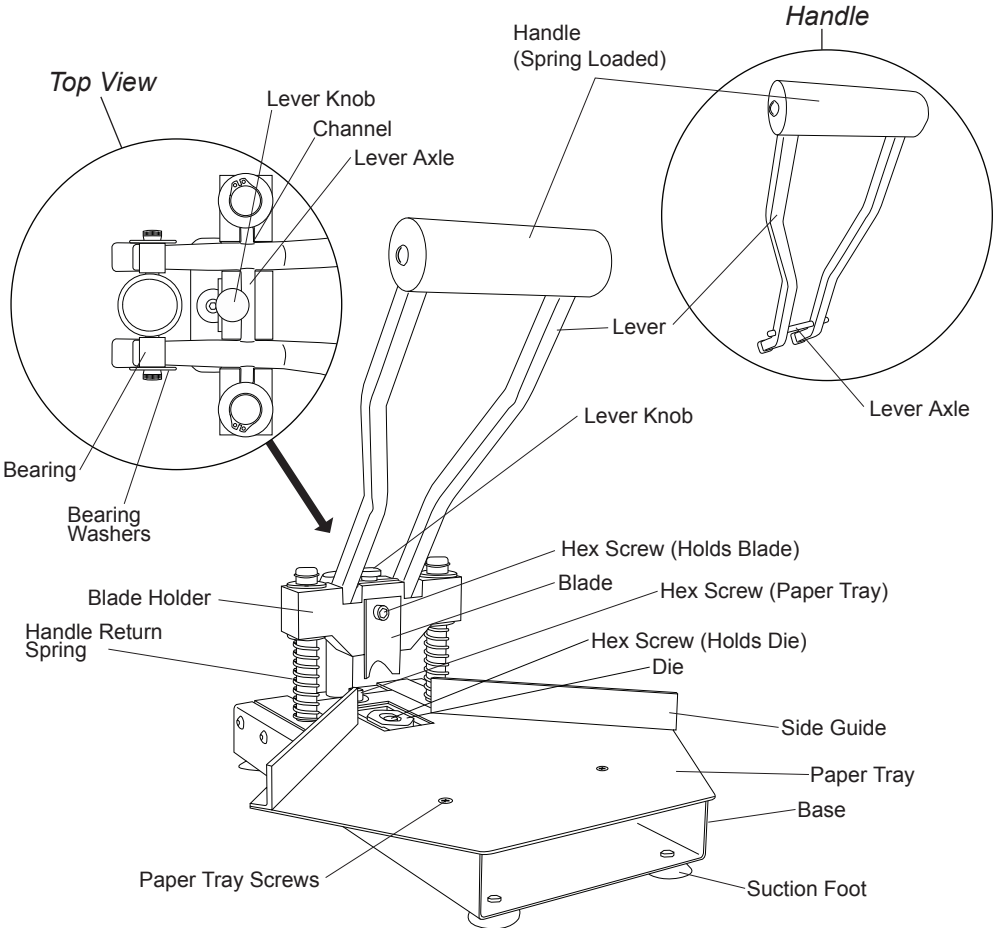

Setting Up Your Machine

■ Install the handle:

1. Loosen the Lever Knob that is on top of the Blade Holder.
2. Place the Lever Axle into the Channel on top of the Blade Holder making sure the lower end of the Lever is placed under the Bearings.
3. Secure the Handle by tightening the Lever Knob.

■ Installing the Blade and Die:

1. Using the 3/16" Hex Wrench, remove the Hex Screw for the Blade and the Hex Screw for the Die.
2. Insert the desired Blade in its place. Tighten down the Hex Screw for the Blade until it is secure.
3. Insert the new corresponding Die facing the new Blade. Replace the Hex Screw for the Die but do not tighten completely.

The Blade must not come down on the Die, this will cause damage

4. Pull down on the Handle bringing the Blade all the way down. Position the Die so that it fits tightly against the Blade. Tighten down the Hex Screw for the Die until it is secure.

Adjusting the Side Guides and Paper Tray

■ It may be necessary at times to adjust either the Side Guides, the Paper Tray, or both due to misalignment.

■ Adjusting the Side Guides

1. Using the 1/8" Hex Wrench, loosen the two screws located on both Side Guides.
2. Using a square (not provided) line up the side guides so that they are aligned with the Die. It may be necessary to bring the blade part way down so that the square can be aligned with the edges of the blade; be sure not to bring the blade all the way down as this could damage your square and the blade.
3. Tighten down the screws when it is positioned as desired.

■ Adjusting the Paper Tray

1. Using the 3/16" Hex Wrench, loosen the Hex Screw for the Paper Tray. Using a philips head screw driver (not provided) loosen the two Paper Tray Screws.
2. Using a square and making sure the Side Guides are properly adjusted, slide the Paper Tray as needed.
3. When the Paper Tray is aligned correctly tighten the Hex Screw and the two Paper Tray Screws until secure.

Cutting

- After the machine has been properly aligned you are ready to cut:
 1. Place the product you are cutting on the surface of the machine. Please note that this machine can only handle up to a maximum of 1" of product. This amount will vary depending on what you are cutting. Please test on scrap.
 2. Hold the product firmly in place keeping it square using the Side Guides.
 3. Bring the Handle straight down with firm pressure so that the Blade moves through the product smoothly.

Tips on Cutting

- Occasionally, the bottom sheet may not cut. If this occurs, place a piece of card stock underneath the stack you are cutting. This will give support to the product you are cutting.
- When cutting business cards or other small sizes, the bottom card may slide forward. Try either cutting a smaller stack, place a piece of card stock underneath the stack, or both.

Lassco  Wizer

485 Hague Street, Rochester, NY 14606 U.S.A.

Tel: 585-436-1934

Fax: 585-464-8665

www.lasscowizer.com

info@lasscowizer.com