

JET[®]

ProSource Packaging, Inc.
14911 Stuebner Airline Suite A
Houston, TX 77069
800-203-0233
www.Machine-Solution.com

Operating Instructions and Parts Manual DC-1200VX Series Dust Collectors



DC-1200VX with Bag Filter Kit



DC-1200VX with Canister Kit

WALTER MEIER (Manufacturing), Inc.
427 New Sanford Road
LaVergne, Tennessee 37086
Ph.: 800-274-6848
www.waltermeier.com



Part No. M-710701
Revision A 03/2011

Copyright © 2011 Walter Meier (Manufacturing), Inc.

Warranty and Service

Walter Meier (Manufacturing) Inc., warrants every product it sells. If one of our tools needs service or repair, one of our Authorized Service Centers located throughout the United States can give you quick service. In most cases, any of these Walter Meier Authorized Service Centers can authorize warranty repair, assist you in obtaining parts, or perform routine maintenance and major repair on your JET® tools. For the name of an Authorized Service Center in your area call 1-800-274-6848.

MORE INFORMATION

Walter Meier is consistently adding new products to the line. For complete, up-to-date product information, check with your local Walter Meier distributor, or visit waltermeier.com.

WARRANTY

JET products carry a limited warranty which varies in duration based upon the product (MW = Metalworking, WW = Woodworking).

90 DAY WARRANTY	1 YEAR WARRANTY	Body Repair Kits Bottle Jacks Cable Pullers Cold Saws Hoists-Air Hoists-Electric Metal forming Mill/Drills Milling Machines MW Bandsaws MW Drill Presses MW Finishing Equipment MW Lathes MW Precision Vises	2 YEAR WARRANTY	Palet Trucks Rigging Equip. Service Jacks Stackers Surface Grinders Tapping Trolleys-Air Trolleys-Electric Web Slings Winches-Electric	3 YEAR WARRANTY	WW Benchtop Tools	5 YEAR WARRANTY	Beam Clamps Chain Hoist- Manual Lever Hoists Pullers-JCH Models Scissor Lift Tables Screw Jacks Trolleys-Geared Trolleys-Plain Winches-Manual WW Air Filtration WW Bandsaws WW Buffers	WW Drill Presses WW Dust Collectors WW Dust Filters WW Dust Fittings WW Jointers WW Lathes WW Planers WW Sanders WW Shapers WW Tablesaws	LIFE LIFETIME WARRANTY	Fastening Tools Mechanics Hand Tools Striking Tools Vises (no -precision) Clamps
<i>Warranty reverts to 1 Year Warranty if woodworking (WW) products listed above are used for industrial or educational purposes.</i>											

WHAT IS COVERED?

This warranty covers any defects in workmanship or materials subject to the exceptions stated below. Cutting tools, abrasives and other consumables are excluded from warranty coverage.

WHO IS COVERED?

This warranty covers only the initial purchaser of the product.

WHAT IS THE PERIOD OF COVERAGE?

The general JET warranty lasts for the time period specified in the product literature of each product.

WHAT IS NOT COVERED?

Five Year Warranties do not cover woodworking (WW) products used for commercial, industrial or educational purposes. Woodworking products with Five Year Warranties that are used for commercial, industrial or education purposes revert to a One Year Warranty. This warranty does not cover defects due directly or indirectly to misuse, abuse, negligence or accidents, normal wear-and-tear, improper repair or alterations, or lack of maintenance.

HOW TO GET SERVICE

The product or part must be returned for examination, postage prepaid, to a location designated by us. For the name of the location nearest you, please call 1-800-274-6848.

You must provide proof of initial purchase date and an explanation of the complaint must accompany the merchandise. If our inspection discloses a defect, we will repair or replace the product, or refund the purchase price, at our option. We will return the repaired product or replacement at our expense unless it is determined by us that there is no defect, or that the defect resulted from causes not within the scope of our warranty in which case we will, at your direction, dispose of or return the product. In the event you choose to have the product returned, you will be responsible for the shipping and handling costs of the return.

HOW STATE LAW APPLIES

This warranty gives you specific legal rights; you may also have other rights which vary from state to state.

LIMITATIONS ON THIS WARRANTY

WALTER MEIER (MANUFACTURING) INC., LIMITS ALL IMPLIED WARRANTIES TO THE PERIOD OF THE LIMITED WARRANTY FOR EACH PRODUCT. EXCEPT AS STATED HEREIN, ANY IMPLIED WARRANTIES OR MERCHANTABILITY AND FITNESS ARE EXCLUDED. SOME STATES DO NOT ALLOW LIMITATIONS ON HOW LONG THE IMPLIED WARRANTY LASTS, SO THE ABOVE LIMITATION MAY NOT APPLY TO YOU.

WALTER MEIER SHALL IN NO EVENT BE LIABLE FOR DEATH, INJURIES TO PERSONS OR PROPERTY, OR FOR INCIDENTAL, CONTINGENT, SPECIAL, OR CONSEQUENTIAL DAMAGES ARISING FROM THE USE OF OUR PRODUCTS. SOME STATES DO NOT ALLOW THE EXCLUSION OR LIMITATION OF INCIDENTAL OR CONSEQUENTIAL DAMAGES, SO THE ABOVE LIMITATION OR EXCLUSION MAY NOT APPLY TO YOU.

Walter Meier sells through distributors only. The specifications in Walter Meier catalogs are given as general information and are not binding. Members of Walter Meier reserve the right to effect at any time, without prior notice, those alterations to parts, fittings, and accessory equipment which they may deem necessary for any reason whatsoever. JET® branded products are not sold in Canada by Walter Meier.

Table of Contents

Warranty and Service	2
Table of Contents	3
Warnings	4
Introduction	5
Specifications	6
Unpacking	7
Shipping Content	7
Base Units	7
Canister Filter Kit	8
30 Micron Bag Filter Kit	8
5 Micron Bag Filter Kit (<i>Optional</i>)	8
Base Unit Assembly	9
Base	9
Motor and Fan Assembly	9
Connector Housing	9
Cone Assembly	10
Hose	10
Filter Bag Kit Assembly	11
Filter Bag Installation	11
Collector Bag Installation	11
Canister Kit Assembly	12
Canister Filter	12
Collector Bag	12
Electrical Connections	13
Turning the Machine On & Off	13
All Models	13
Remote Control (<i>Optional Accessory</i>)	13
Turning the DC-RC230 On & Off	13
Changing Operating Frequency	14
Installing the DC-RC Remote Power Control	14
Maintenance	15
Cleaning the Filter Bag - DC-1200VX-BK1 and DC-1200VX-BK3	15
Removing the Collector Bag – DC-1200VX-BK1 and DC-1200VX-BK3	15
Cleaning the Canister Filter – DC-1200VX-CK1 and DC-1200VX-CK3	15
Removing the Collector Bag – DC-1200VX-CK1 and DC-1200VX-CK3	15
Motor	15
Connecting the Dust Collector to a Machine	15
Grounding the Dust Collection System	15
Parts Breakdown for the DC-1200VX Dust Collector	16
Ordering Replacement Parts	17
Parts List for the DC-1200VX Dust Collector	17
Canister Filter Kit (708639B)	19
30 Micron Filter Bag Kit (708636F)	20
5-Micron Filter Bag Kit (708636MF) <i>Optional Accessory</i>	21



Warnings

1. Read and understand the entire owner's manual before attempting assembly or operation.
2. Read and understand the warnings posted on the machine and in this manual. Failure to comply with all of these warnings may cause serious injury.
3. Replace the warning labels if they become obscured or removed.
4. This dust collector is designed and intended for use by properly trained and experienced personnel only. If you are not familiar with the proper and safe operation of a dust collector, do not use until proper training and knowledge have been obtained.
5. Do not use this dust collector for other than its intended use. If used for other purposes, Walter Meier (Manufacturing) Inc., disclaims any real or implied warranty and holds itself harmless from any injury that may result from that use.
6. Always wear approved safety glasses/face shields while using this dust collector. Everyday eyeglasses only have impact resistant lenses; they are not safety glasses.
7. Before operating this dust collector, remove tie, rings, watches and other jewelry, and roll sleeves up past the elbows. Remove all loose clothing and confine long hair. Non-slip footwear or anti-skid floor strips are recommended. Do **not** wear gloves.
8. Wear ear protectors (plugs or muffs) during extended periods of operation.
9. Some dust created by power sanding, sawing, grinding, drilling and other construction activities contain chemicals known to cause cancer, birth defects or other reproductive harm. Some examples of these chemicals are:
 - Lead from lead based paint.
 - Crystalline silica from bricks, cement and other masonry products.
 - Arsenic and chromium from chemically treated lumber.Your risk of exposure varies, depending on how often you do this type of work. To reduce your exposure to these chemicals, work in a well-ventilated area and work with approved safety equipment, such as face or dust masks that are specifically designed to filter out microscopic particles.
10. Do not operate this machine while tired or under the influence of drugs, alcohol or any medication.
11. Make certain the switch is in the **OFF** position before connecting the machine to the power supply.
12. Make certain the machine is properly grounded.
13. Make all machine adjustments or maintenance with the machine unplugged from the power source.
14. Remove adjusting keys and wrenches. Form a habit of checking to see that keys and adjusting wrenches are removed from the machine before turning it on.
15. Keep safety guards in place at all times when the machine is in use. If removed for maintenance purposes, use extreme caution and replace the guards immediately.
16. Check damaged parts. Before further use of the machine, a guard or other part that is damaged should be carefully checked to determine that it will operate properly and perform its intended function. Check for alignment of moving parts, binding of moving parts, breakage of parts, mounting and any other conditions that may affect its operation. A guard or other part that is damaged should be properly repaired or replaced.
17. Provide for adequate space surrounding work area and non-glare, overhead lighting.
18. Keep the floor around the machine clean and free of scrap material, oil and grease.
19. Keep visitors a safe distance from the work area. **Keep children away.**



Warnings

20. Make your workshop child proof with padlocks, master switches or by removing starter keys.
21. Give your work undivided attention. Looking around, carrying on a conversation and “horse-play” are careless acts that can result in serious injury.
22. Do not use the dust collector for anything except wood dust. Materials such as liquids, metal shavings, metal dust, screws, glass, plastic or rock can cause sparks and/or damage when coming into contact with any part of the dust collector.
23. Use recommended accessories; improper accessories may be hazardous.
24. Maintain tools with care. Follow instructions for lubricating and changing accessories.
25. Turn off the machine before cleaning. Use a brush or compressed air to remove chips or debris — do not use your hands.
26. Do not stand on the machine. Serious injury could occur if the machine tips over.
27. Never leave the machine running unattended. Turn the power off and do not leave the machine until it comes to a complete stop.
28. Remove loose items and unnecessary work pieces from the area before starting the machine.
29. Never place hands near the inlet of the machine.
30. Always make certain machine is off and unplugged when making any connections to the inlet.

Familiarize yourself with the following safety notices used in this manual:

CAUTION This means that if precautions are not heeded, it may result in minor injury and/or possible machine damage.

WARNING This means that if precautions are not heeded, it may result in serious injury or possibly even death.

- - SAVE THESE INSTRUCTIONS - -

Introduction

This manual is provided by Walter Meier (Manufacturing) Inc., covering the safe operation and maintenance procedures for model DC-1200VX Series Dust Collectors. This manual contains instructions on installation, safety precautions, general operating procedures, maintenance instructions and parts breakdown. This machine has been designed and constructed to provide years of trouble free operation if used in accordance to instructions set forth in this manual. If there are any questions or comments, please contact either your local supplier or Walter Meier (Manufacturing) Inc.

Specifications

Main Dust Collection Kits

<i>Model Numbers</i>	<i>Stock Numbers</i>
DC-1200VX-BK1 (Single Phase, with 30 Micron Bag Filter Kit)	710701K
DC-1200VX-BK3 (Three Phase, with 30 Micron Bag Filter Kit)	710703K
DC-1200VX-CK1 (Single Phase, with Canister Filter Kit)	710702K
DC-1200VX-CK3 (Three Phase, with Canister Filter Kit)	710704K

Base Machine

Stock Number	710701	710703
Impeller Diameter	12	12
Sound Rating at 3 foot distance	70-80 db	70-80 db
1-Hose Connection Diameter (in.)	6	6
2-Hose Connection Diameter (in.)	4	4
Air Flow (CFM)	1,200	1,200
Velocity at 4" (FPM)	13,745	13,745
Static Pressure (inch of water)	11.5	11.5
Overall Dimensions with Bag Filter installed-approx.(in.)	37L x 28W x 79H	37L x 28W x 79H
Motor, TEFC	2HP, 1PH, 230V only	2HP, 3PH, 230/460V
.....	8A, 60Hz	Prewired 230V, 6/3A, 60Hz
Net Weight, approximate (lbs)	127	127

30 Micron Filter Bag Kit

Stock Number	708636F
Filter Bag Efficiency	96% of 30 micron particles
Filter Bag Length, installed (in.)	32
Filter and Collector Bag Diameter (in.)	20
Collector Bag Capacity (cu. ft.)	5.3
Collector Bag Length, installed (in.)	29

Canister Filter Kit

Stock Number	708639B
Canister Length (in.)	25
Canister Efficiency	86% of 1 micron particles; 98% of 2 micron particles
Collector Bag Diameter (in.)	20
Collector Bag Capacity (cu. ft.)	5.3
Collector Bag Length, installed (in.)	29

5 Micron Filter Bag Kit (Optional Accessory)

Stock Number	708636MF
Filter Bag Efficiency	74% of 1 micron particles; 92% of 3 micron; 98% of 5 micron
Filter Bag Length, installed (in.)	32
Filter and Collector Bag Diameter (in.)	20
Collector Bag Capacity (cu. ft.)	5.3
Collector Bag Length, installed (in.)	29

IR Remote Control Unit (Optional Accessory)

Stock Number (main unit and remote control switch) (115V only)	708636D
Stock Number (Remote Control Switch only)	708636T

The above specifications were current at the time this manual was published, but because of our policy of continuous improvement, Walter Meier (Manufacturing) Inc., reserves the right to change specifications at any time and without prior notice, without incurring obligations.



Read and understand the entire contents of this manual before attempting set-up or operation! Failure to comply may cause serious injury.

Unpacking

The table below lists the shipping cartons that are included with the various models of the DC-1200 Dust Collector.

1. Locate your particular model and verify that you have received the all the correct cartons.
2. Check contents of each carton against the shipping content listings on this and the following page.
3. Report any damage to your distributor.
4. Do not discard any shipping material until after the dust collector has been assembled and is running properly.

	Base Unit (SN 710701)	Base Unit (SN 710703)	30M Filter Bag Kit (SN 708636F)	Canister Filter Kit (708639B)
DC-1200VX-BK1	x		x	
DC-1200VX-CK1	x			x
DC-1200VX-BK3		x	x	
DC-1200VX-CK3		x		x

Table – DC-1200VX Dust Collector cartons

Hardware Bag for Base Unit (SN DC1100-HP)

- 16 – M8 x 16 Hex Cap Screws (K)
- 22 – M8 Flat Washers (L)
- 8 – M6 x 12 Pan Head Flange Screws (M)
- 6 – M8 Hex Nuts (N)

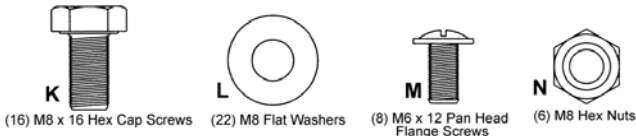

Base Assembly Hardware

Hardware Bag for Cone Assembly (SN DC1100-HP2)

- 1 – M8 x 16 Hex Cap Screw (O)
- 1 – M8 Flat Washer (P)
- 1 – M8 Hex Nut (R)
- 4 – M6 x 12 Hex Cap Screws (S)
- 4 – M6 Hex Nuts (T)

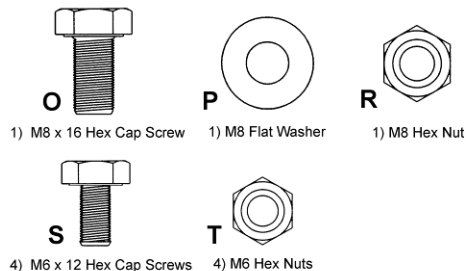

Cone Assembly Hardware

Shipping Content

Base Units

(SN 710701 and 710703)

- 1 – Housing (A)
- 2 – Hose Clamps (B)
- 1 – Hose (C)
- 1 – Impeller (Motor/Fan Assembly) (D)
- 1 – Inlet Port (E)
- 1 – Impeller Cover (F)
- 3 – Support Legs (G)
- 1 – Base (H)
- 4 – Casters (J)
- 1 – Owner's Manual (not shown)
- 1 – Warranty Card (not shown)
- 1 – Hardware Bag Base Assly. (SN DC1100-HP)
- 1 – Hardware Bag, Cone Assly. (SN DC1100-HP2)

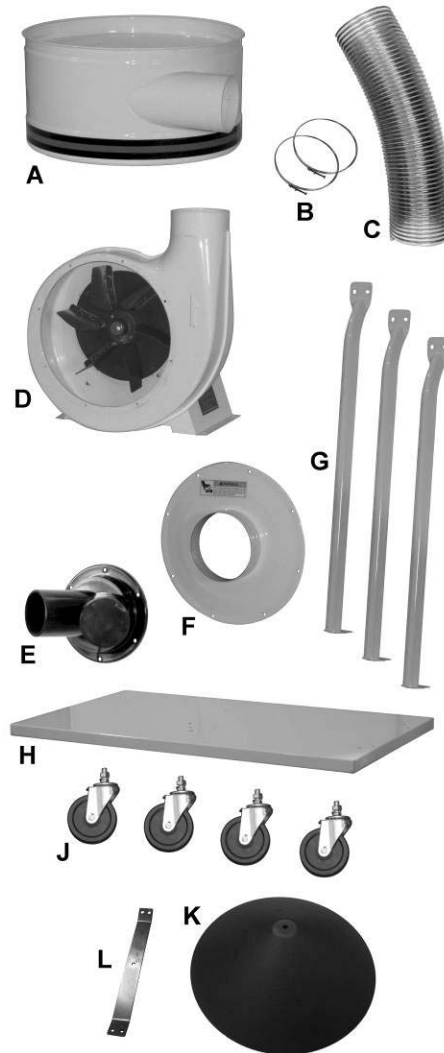

Base Machine Shipping Contents

Canister Filter Kit

(SN 708639B)

- 1 – Handle (O)
- 1 – Canister Filter (P)
- 1 – Snap Ring (Q)
- 5 – Collector Bags (R)
- 1 – Canister Filter Hardware Bag (SN DC1100-CHP)

Contains:

- (2) M10 Hex Nuts (S)
- (2) M10 Flat Washers (T)
- (1) M10 Lock Washer (U)
- (4) Knobs (V)

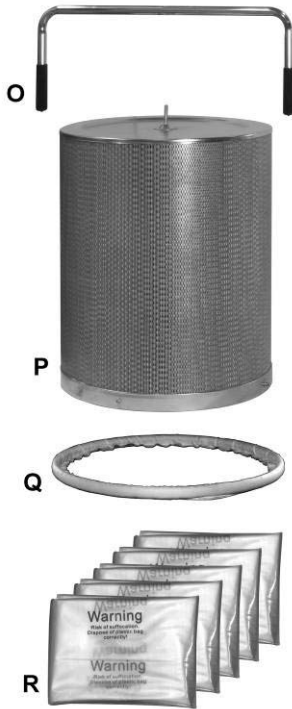

Canister Filter Kit Contents

Canister Filter Hardware

(SN DC1100-CHP)

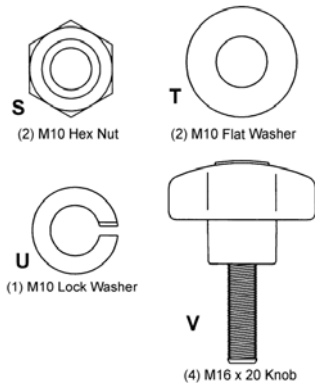

Canister Filter Hardware

30 Micron Bag Filter Kit

(SN 708636F)

- 1 – Upper Bag Hanger (Y)
- 1 – Hanger Bracket (Z)
- 1 – Collector Bag (X)
- 1 – Filter Bag (W)
- 1 – Retainer Strap (AA)

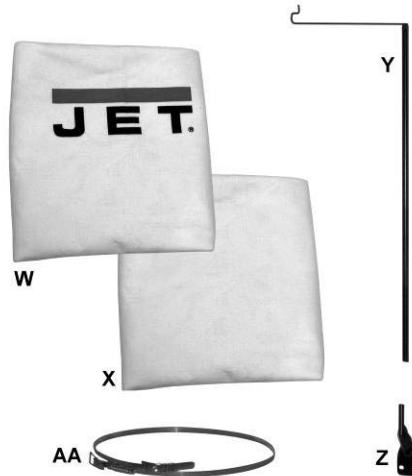

30 Micron Bag Filter Kit Contents

5 Micron Bag Filter Kit (Optional)

(SN 708636MF)

- 1 – Upper Bag Hanger (BB)
- 1 – Hanger Bracket (CC)
- 1 – Filter Bag (DD)
- 5 – Collector Bags (EE)
- 1 – Retainer Strap (FF)
- 1 – Snap Ring (GG)

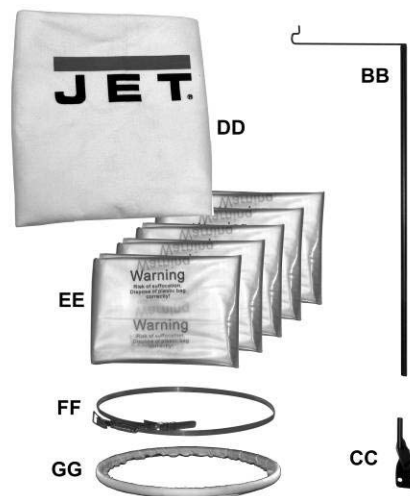

5 Micron Bag Filter Kit Contents

Base Unit Assembly

Base

1. Install *four* casters to the under side of the base as pictured in Fig. 2.

Referring to Figure 1:

2. Thread the *hex nut* (B) onto the caster shaft. Then slide the *lock washer* (A) over the caster shaft. Thread the caster shaft into the threaded hole on the underside of the base, turn until snug. Tighten the *nut* (B) against the base with a 14mm wrench. This will give the caster proper clearance.

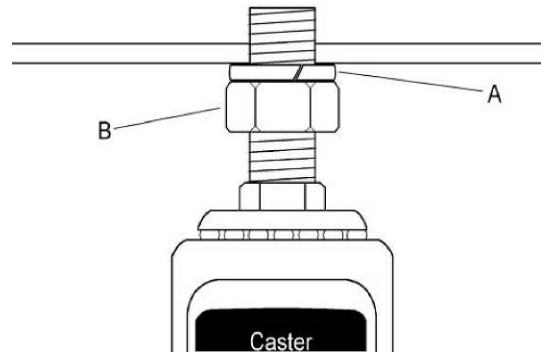

Figure 1

Motor and Fan Assembly

Referring to Figure 2:

3. Place the *base* (C) with casters on the ground. Attach the *motor and fan assembly* (A) to the base using four each M8 x 16 hex cap screws, and M8 flat washers (B). Tighten with a 13mm wrench.

⚠WARNING The dust collector must not be connected to the power source during assembly. Failure to comply may result in serious injury!

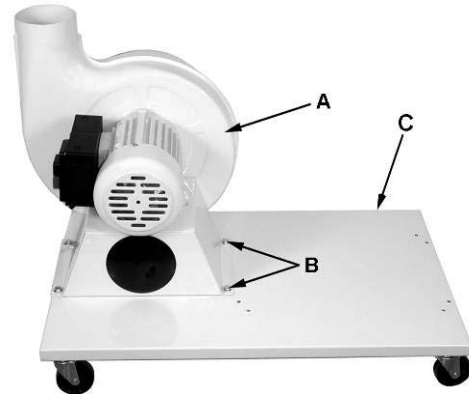

Figure 2

Referring to Figure 3:

4. Attach *impeller cover* (A) to *fan housing* (D) using eight M6 x 12 *pan head screws* (B). Press the *inlet ports* (C) onto the inlet guard until it snaps into place.

⚠WARNING To reduce the risk of injury from moving parts, always keep inlet port covered with the caps provided, if they are not connected to a hose. Failure to comply may result in serious injury!

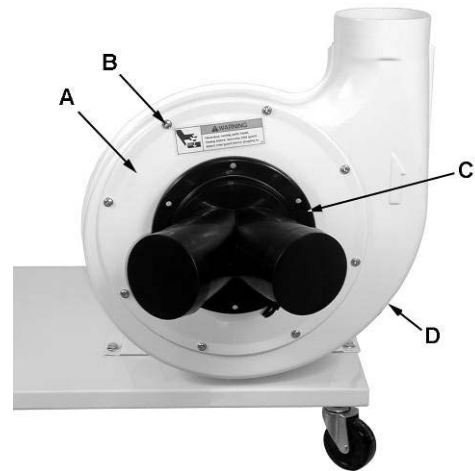

Figure 3

Connector Housing

5. Attach three *support legs* (A, Fig. 4) to the base using six M8 x 16 hex cap bolts and six M8 flat washers (B, Fig. 4). Hand-tighten only at this time.

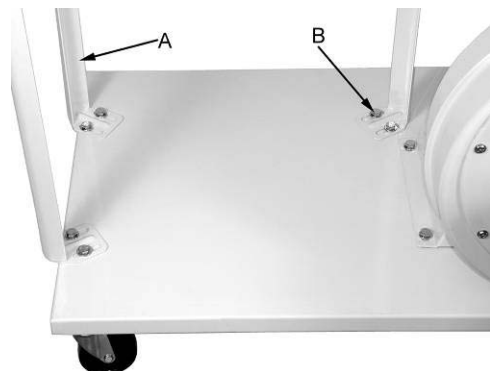

Figure 4

6. Install the *housing* (A, Fig. 5) to two *support legs* (B, Fig. 5) using four M8 x 16 hex cap bolts, eight M8 flat washers, and four M8 hex nuts (C, Fig. 5). Be sure hose opening faces fan housing.

Note: For models DC-1200VX-BK1 or DC-1200VX-BK3 only – Before attaching third support bracket, place the *hanger bracket* (D, Fig.5) between the support bracket and the housing.

7. Tighten all nuts and bolts at this time with a 13mm wrench.

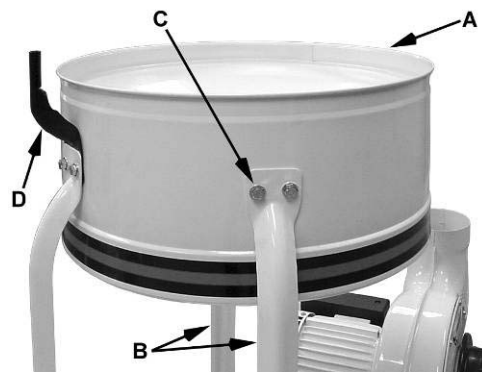

Figure 5

Cone Assembly

Referring to Figure 6:

8. Mount the cone *support bracket* (E) to the housing with four M6x12 hex cap screws (F), and tighten from beneath with four M6 hex nuts (G).
9. Install the *cone* (H) from beneath using the M8x16 hex cap screw (J), M8 flat washer (K), and M8 hex nut (L), and tighten.

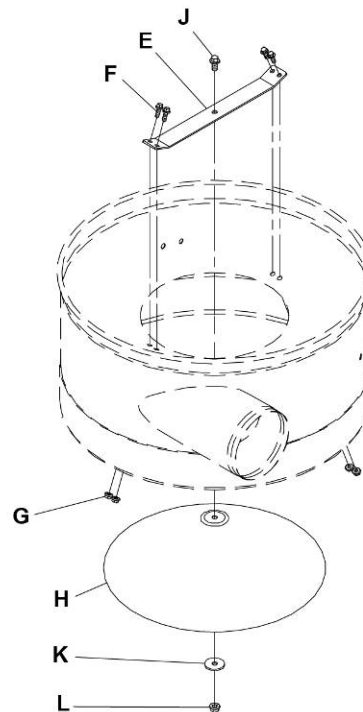

Figure 6

Hose

Referring to Figure 7:

10. Attach the *hose* (B) between the *fan housing* (A) and the *impeller housing* (D) with two *clamps* (C). Tighten the clamps to secure the hose.

This completes the *Base Unit* assembly. If you purchased the *DC-1200VX-BK1* or *DC-1200VX-BK3 Dust Collector* (filter bag version), continue on the following page. If you purchased the *DC-1200VX-CK1* or *DC-1200VX-CK3 Dust Collector* (canister filter version), proceed to *Canister Kit Assembly* section on page 12.

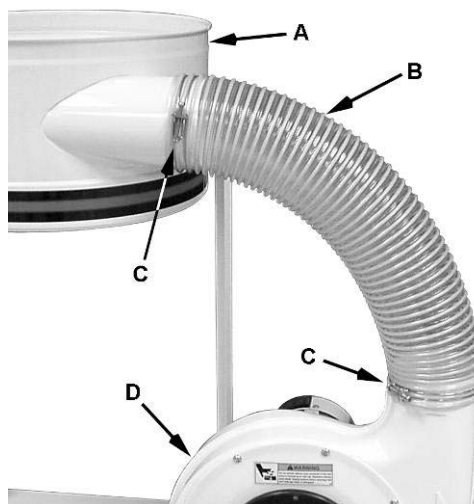

Figure 7

Filter Bag Kit Assembly

If you purchased Model DC-1200VX-BK1 or DC-1200VX-BK3 Dust Collector, this section describes the assembly and installation of the contents of the 30 Micron Filter Bag Kit (SN 708636F). These instructions also apply to the optional 5 Micron Filter Bag Kit (SN 708636MF).

Filter Bag Installation

Referring to Figure 8:

1. Place the *hanger* (A) on the *hanger bracket* (B).
2. Slide the *filter bag loop* (C) over the hanger hook.
3. Feed the *retainer strap* (D) through the loops on the *filter bag* (E) and fasten to the *collector housing* (F).

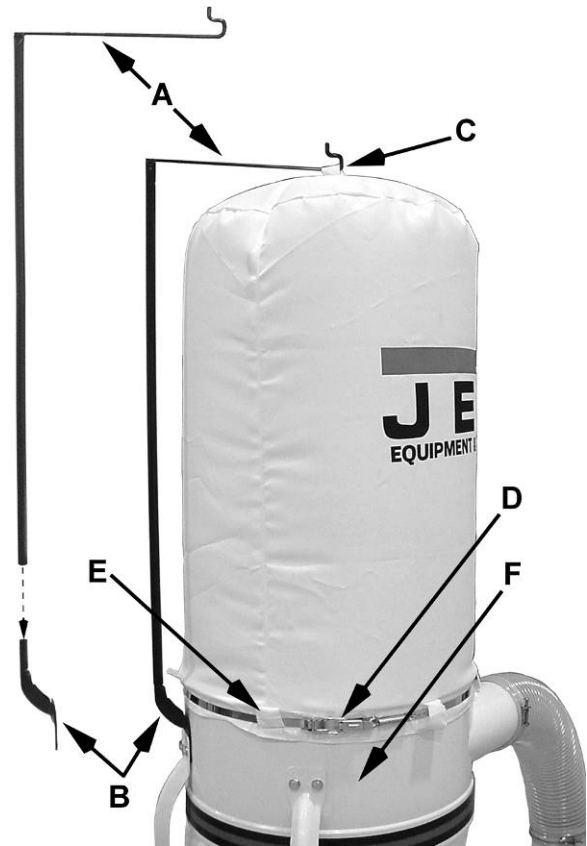

Figure 8

Collector Bag Installation

Referring to Figure 9:

4. Insert the ring of the *collector bag* (A) at an angle into the *housing* (B) through the opening at the bottom. Pull down on the bag to make sure it “seats” in the housing.
5. Position the plastic window in front so that you can easily see when the collector bag is full.

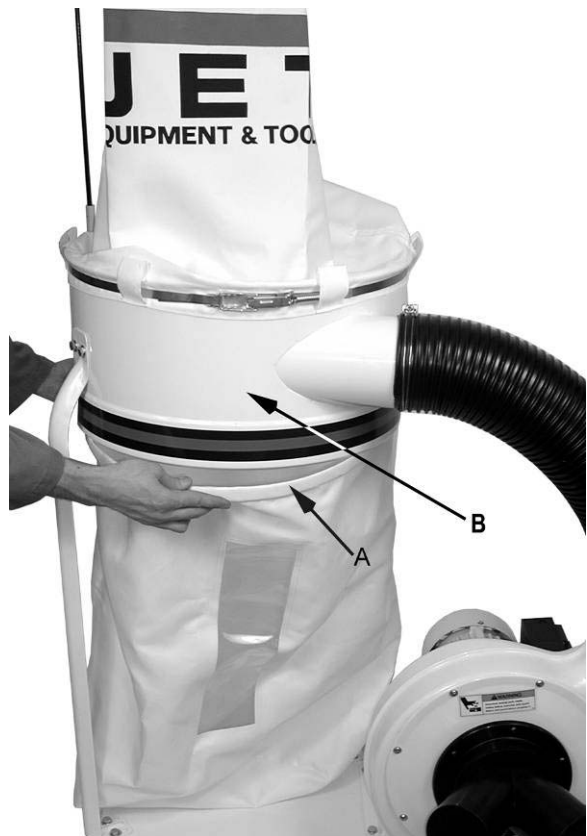

Figure 9

After completing the filter bag and collector bag installation, proceed to *Electrical Connections*.

Canister Kit Assembly

If you purchased Model DC-1200VX-CK1 or DC-1200VX-CK3 Dust Collector, this section describes the assembly and installation of the contents of the Canister Kit (SN 708636F).

Canister Filter

1. Mount the handle onto the canister filter with two M10 hex nuts, two M10 flat washers, and a M10 lock washer (Figure 10).
2. Mount the canister filter on top of the *collector housing* (A, Fig. 5) and tighten the knobs on the *canister filter* (Figure 10).

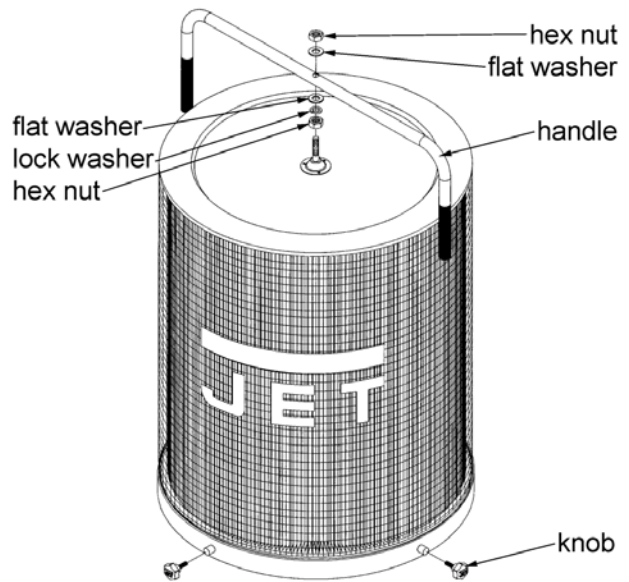

Figure 10

Collector Bag

3. Place the ring over the top of the plastic bag and fold over the bag approximately three inches, Figure 11.



Figure 11

4. Insert the *snap ring* (A, Fig. 12) of the collector bag into the bottom of the housing at an angle.
5. Pull down on the ring to make sure it “seats” in the housing.

Note: make sure the snap ring “snaps” into place in the housing, and also that the plastic bag hangs down approximately 3” so that there are no air leaks.



Figure 12

Electrical Connections

⚠WARNING All electrical connections must be done by a qualified electrician. All adjustments or repairs must be done with the dust collector disconnected from the power source, unplugged. Failure to comply may result in serious injury!

The DC-1200VX *single phase* dust collectors are rated for **230V Only**. The dust collector is not supplied with a plug. Use a plug and outlet rated at least 20 amps. The circuit for the machine should also be protected by at least a 20 amp circuit breaker or fuse.

The DC-1200VX *three phase* dust collectors are rated for 230V/460V, **Prewired 230V**. If you wish to run these on 460 volt, refer to the wiring diagram found on the inside of the switch box cover.

Keep in mind that a circuit being used by other machines, tools, lights, heaters, etc. at the same time will add to the electrical load. A dedicated circuit to the dust collector will give you the best results since dust collectors are generally used at the same time other tools are running.

Turning the Machine On & Off

⚠WARNING This machine is intended for indoor use only.

All Models

Before hooking up to the power source, make sure that the switch is in the off position.

Turn the dust collector on by pressing the *Start* button mounted next to the motor. Press the *Stop* button to turn off the dust collector.

Remote Control (Optional Accessory)

The DC-RC230 RF Remote Power Control unit is available as an optional accessory (contact Customer Service by calling the number on the cover).

Important: The *DC-RC230 Remote Power Control* can be used for activating Dust Collection units powered by 230V *only* up to 3HP, **single phase only**.

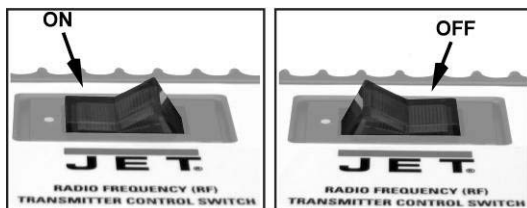

Figure 13A

Figure 13B

Dust Collector RF Remote Power Control (optional)

The *DC-RC230 Remote Power Control* (Figure 14) should be used for activating Dust Collection units powered by 230V **only** up to 3HP, 1 Phase. The DC-RC230 Remote Power Control unit is rated at 230V, *Single Phase* only. Use an outlet rated at least 20amps. The circuit for the device being controlled by the DC-RC230 should also be protected by at least a 20 amp circuit breaker or fuse.

Before hooking up to the power source, make sure that the switch is initially in the off position on both the dust collector and *remote control unit* (Figure 13).

Turning the DC-RC230 On & Off

⚠WARNING This machine is intended for indoor use only.

1. Plug the dust collector into the *main unit* (Figure 14) and plug the main unit into the power outlet.

To start a machine or device:

2. Turn the machine itself on.
3. On the main unit place the switch to the *ON* position (Figure 13A). The red LED on the main unit should light up.
4. Press the button on the *remote control transmitter* (Figure 14) to turn the machine on.
5. To stop the machine, press the button on the *remote control transmitter* again.



Figure 14

When the machine is running, it can be stopped by placing the switch on the main unit in the off position (Figure 14). To restart, repeat steps 3 and 4.

Changing Operating Frequency

If several devices are controlled by the same type remote control unit, each remote control unit can be set to operate at its' own unique operating frequency as follows:

Referring to Figure 15:

1. Unplug the DC-RC230 *Remote Power Control* unit.
2. Remove the back covers of the *main unit* (A) and *remote control switch* (B).
3. Locate the *DIP switch* (C) in each unit.
4. Change the position of the DIP switches in the *main unit* (A) to any combination desired as long as they are not the same as other units that may be present and located within the radio frequency range.
5. Set the *DIP switches* (C) in the *remote control switch* (B) to match the switch settings in the *main unit* (A).
6. Replace the back covers to the main unit and remote control switch.
7. Operate a device as described in *Turning the DC-RC230 On & Off* and verify that other devices using the same type remote control do not turn on.

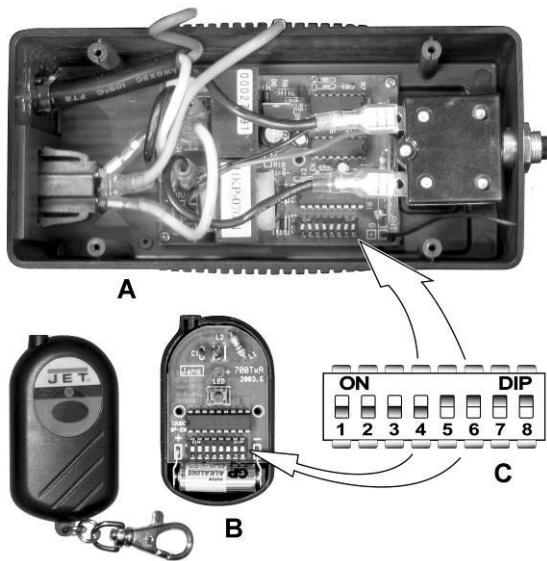

Figure 15

To mount the *DC-RC230 Remote Power Control* (refer to Figure 16):

Note: Mounting hardware is not included and must be supplied by the machine's owner or user.

1. Place *RC Power Control Unit* (A) on the open clearing of the *base* (B) of the dust collector near the *motor* (C).
2. Using a marker, mark the base through the mounting holes of the power control units mounting tabs.
3. Drill two holes (D) through the base where marked.
4. Insert screws through the tabs and base. Place washers and hex nuts on the threaded ends of the screw underneath the base and tighten.

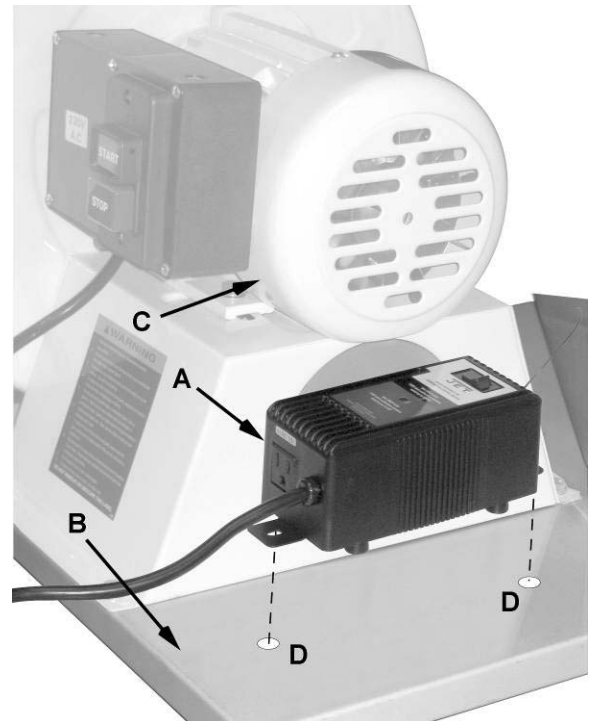

Figure 16

Installing the DC-RC Remote Power Control

The *DC-RC230 Remote Power Control* unit can be placed anywhere for convenience and portability if used to control other machines or it can be mounted as a permanent part of a machine, such as the DC-1200VX Dust Collector.

Maintenance

▲WARNING Never perform maintenance on this machine before turning switch off and removing plug from power source. Failure to comply may cause serious injury!

Cleaning the Filter Bag - DC-1200VX-BK1 and DC-1200VX-BK3

▲CAUTION Wearing a particle mask or respirator for protection against fine dust particles during cleaning is highly recommended.

During first use and after cleaning, the filter bag may allow some dust to escape. This is normal and will stop after a short period of time.

Clean both the filter and collector bags frequently to keep the collector's performance at its optimum. To clean:

1. Disconnect the machine from the power source.
2. Unhook the filter bag from the hanger and shake the bag so that the majority of the dust falls into the collector bag.
3. Loosen the retaining strap, and remove the filter bag from the housing.
4. Turn the bag inside out and clean.
5. Turn the bag outside in and re-attach to the housing using the retainer strap to secure.

Removing the Collector Bag – DC-1200VX-BK1 and DC-1200VX-BK3

1. Disconnect the machine from the power source.
2. Remove the collector bag by pushing the ring of the collector bag upwards and pulling the bag out at an angle.
3. Empty the contents into an appropriate container.
4. Turn the bag inside out and clean.
5. Turn the bag outside in and insert into the housing.

To replace the collector bag, refer to *Collector Bag Installation* on page 11.

Use the proper type hose to connect the dust collector to the machine being operated. Dryer vent hose is not acceptable for this purpose. Contact your nearest JET distributor for the full line of JET *Dust Collector Hoses and Accessories*. Customize your installation and obtain maximum performance with JET's dust hoods, hoses, clamps, fittings, and blast gates.

Cleaning the Canister Filter – DC-1200VX-CK1 and DC-1200VX-CK3

▲WARNING Never perform maintenance on this machine before turning switch off and removing plug from power source. Failure to comply may cause serious injury!

Clean both the filter and collector bags frequently to keep the collector's performance at its optimum.

To clean the filter, turn the handle a couple of rotations so the dust falls into the collector bag.

Removing the Collector Bag – DC-1200VX-CK1 and DC-1200VX-CK3

▲CAUTION Wearing a particle mask or respirator for protection against fine dust particles during cleaning is highly recommended.

1. Disconnect the machine from the power source outlet.
2. Remove the collector bag by pushing the ring of the collector bag upwards at an angle and pulling the bag and snap ring out.
3. Empty the contents into an appropriate container.

To replace the collector bag, refer to the *Collector Bag* section on page 12.

Motor

Make frequent inspections of the motor fan and blow out (with low pressure air hose) or vacuum any accumulation of foreign material in order to maintain normal motor ventilation.

Connecting the Dust Collector to a Machine

Use the proper type hose to connect the dust collector to the machine being operated. Dryer vent hose is not acceptable for this purpose. Contact your nearest JET distributor for the full line of JET Dust Collector Hoses and Accessories. Customize your installation and obtain maximum performance with JET's dust hoods, hoses, clamps, fittings, and blast gates.

Grounding the Dust Collection System

The dust collection system includes the dust collector and the hose, or ductwork you use to connect the tools. The dust collector is grounded through the ground wire in the cord. The hose or ductwork you use to connect the tool to the dust collector must also be grounded.

Parts Breakdown for the DC-1200VX Dust Collector

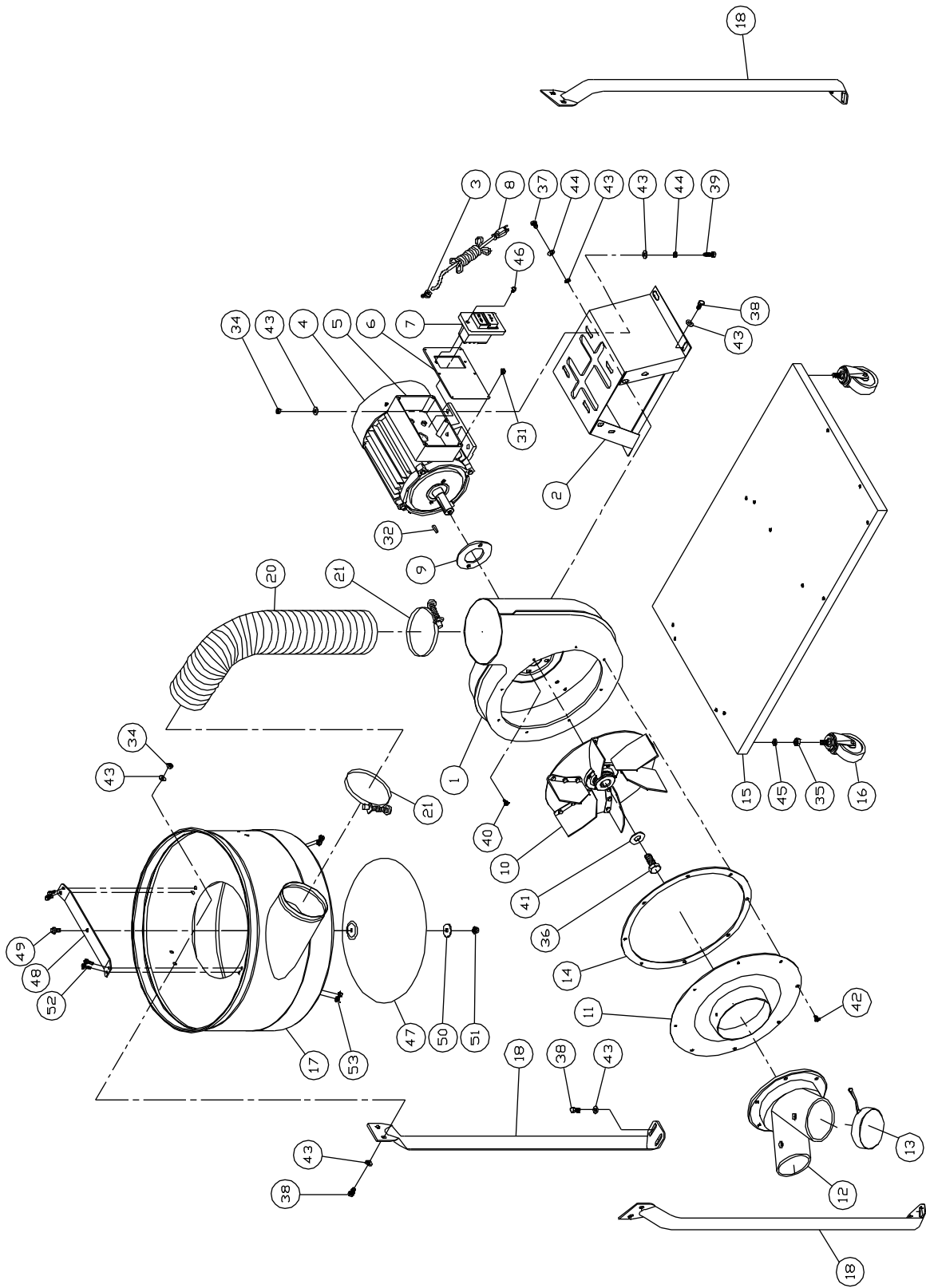

Ordering Replacement Parts

To order parts or reach our service department, call 800-274-6848, Monday through Friday (see our website for business hours, www.waltermeier.com). Having the Model Number and Serial Number of your machine available when you call will allow us to serve you quickly and accurately.

Parts List for the DC-1200VX Dust Collector

Index No.	Part No.	Description	Size	Qty
1	411035W	Impeller Housing		1
2	411026W	Motor Bracket		1
3	998621	Strain Relief		1
4	MA411003	Motor	2 HP, 1Ph	1
	MA411003-3	Motor	2 HP, 3 Ph	1
	DC1100-50W	Motor Fan Cover (not shown)		1
	MF411012	Motor Fan (not shown)		1
	CA003030	Running Capacitor (not shown)	30MFD, 300V	1
	CA020010	Starting Capacitor (not shown)	200MFD, 125V	1
5	411051	Switch Box		1
6	411053	Switch Plate		1
7	994542	Switch	1 Ph	1
	DC1900-23B	Switch	3 Ph	1
8	IC420002	Power Cord	1 Ph	1
	IC420002-3	Power Cord	3 Ph	1
9	420051	Motor Packing		1
10	AB411059	Impeller	12"	1
11	411036W	Inlet Guard		1
12	427028	Inlet Port	2 @ 4"	1
13	420203	Inlet Cap		2
14	430034	Inlet Flange Packing		1
15	411041W	Base		1
16	402036	Pivoting Caster		4
17	420012W	Housing		1
18	402004W	Support		3
20	411009	Hose	5"x65(CM)	1
21	420010	Ring Clamp	5"	2
31	ST039304	Tapping Screw	M3.5x12(AB)	6
32	KS050525	Key	5x5x25	1
34	TS-1540061	Nut	M8	10
35	TS-0561031	Nut	3/8"-16UNC	4
36	SH080402	Hex Head Bolt	M8x20 L.H	1
37	TS-1490011	Hex Head Bolt	M8x12	4
38	TS-1490021	Hex Head Bolt	M8x16	16
39	TS-1490041	Hex Head Bolt	M8x25	4
40	TS-1554041	Pan Head Bolt W/Flange	M6x12	2
41	TS-0680031	Flat Washer	M8	1
42	TS-1554041	Pan Head Bolt W/Flange	M6x12	8
43	TS-0680031	Flat Washer	M8	34
44	TS-0720081	Spring Washer	M8	8
45	TS-1551071	Spring Washer	M10	4
46	ST059304	Tapping Screw	M5x12	2
47	DC1100-47	Cone		1
48	DC1100-47-1	Support Bracket		1
49	TS-1490021	Hex Cap Screw	M8x16	1
50	TS-1550061	Flat Washer	M8	1
51	TS-1540061	Hex Nut	M8	1
52	TS-1482021	Hex Head Bolt	M6x12	4
53	TS-2311061	Hex Nut	M6	4

Index No.	Part No.	Description	Size	Qty
.....	DC1200A-NP	Name Plate (not shown)		1
.....	DC1100-HP	Hardware Package (not shown)		1
.....	DC1100-HP2	Hardware Package for cone assy (index # 49 thru 53)		1
.....	DC1200A-CS	Centrifugal Switch (not shown)		1
.....	DC1900-53	Warning Label (not shown)		1
.....	DC1200-53	Grounding Label (not shown)		1
.....	DC1200-54	Direction Label (not shown)		1

Canister Filter Kit (708639B)

Index No.	Part No.	Description	Size	Qty
.....	708639B.....	Canister Filter Kit (<i>index #1-24</i>).....		
1.....	331050.....	Handle.....		1
2.....	TS-1540071.....	Hex Nut.....	M10	2
3.....	TS-1550071.....	Flat Washer.....	M10	2
4.....	TS-2361101.....	Lock Washer.....	M10	1
5.....	BR000052.....	Rivet.....	5-2	3
6.....	331014.....	Bracket.....		1
7.....	150623.....	Pad.....		1
8.....	331051.....	Soft Grip Handle.....		2
9.....	TS-1540041.....	Hex Nut.....	M6	8
10.....	708739.....	Filter.....		1
11.....	331052.....	Shaft.....		1
12.....	TS-1482041.....	Hex Cap Screw.....	M6X20	4
13.....	TS-2361061.....	Lock Washer.....	M6	4
14.....	TS-1550041.....	Flat Washer.....	M6	4
15.....	331012.....	Scraper.....		2
16.....	331017.....	Strip.....		2
17.....	331015.....	Press Plate.....		2
18.....	TS-1482021.....	Hex Cap Screw.....	M6x12	4
19.....	331037.....	Knob.....		4
20.....	331031.....	Pad.....		1
21.....	331009.....	Support.....		1
22.....	ST049200.....	Tapping Screw.....	M4X8	4
23.....	331038.....	Snap Ring.....		1
24.....	709563.....	Plastic Bag.....		5
.....	DC1100-CHP.....	Canister Hardware Package.....		

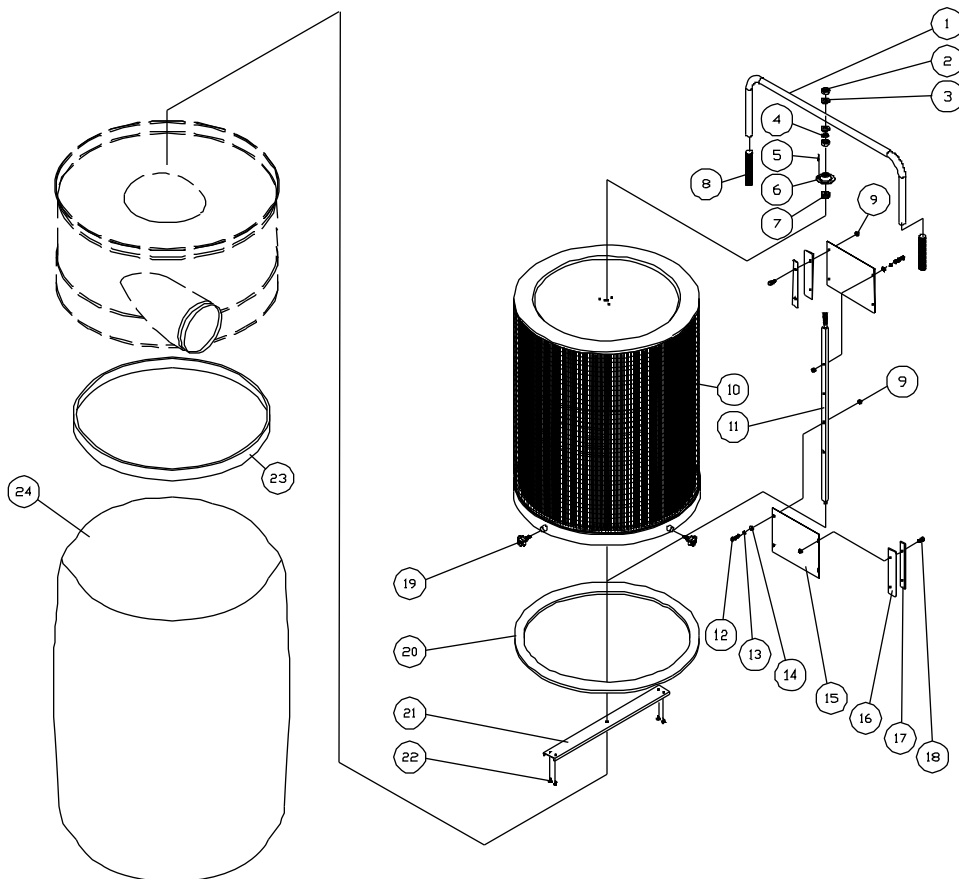

30 Micron Filter Bag Kit (708636F)

Index No.	Part No.	Description	Size	Qty
.....	708636F	30 Micron Filter Bag Kit (<i>index #1-5</i>)
1	708698	Filter Bag	30 Micron Bag	1
2	AB410012	Retainer Strap		1
3	708699A	Collection Bag		1
4	430038	Hanger	30 Micron Bag Hanger	1
5	523011W	Hanger Bracket		1

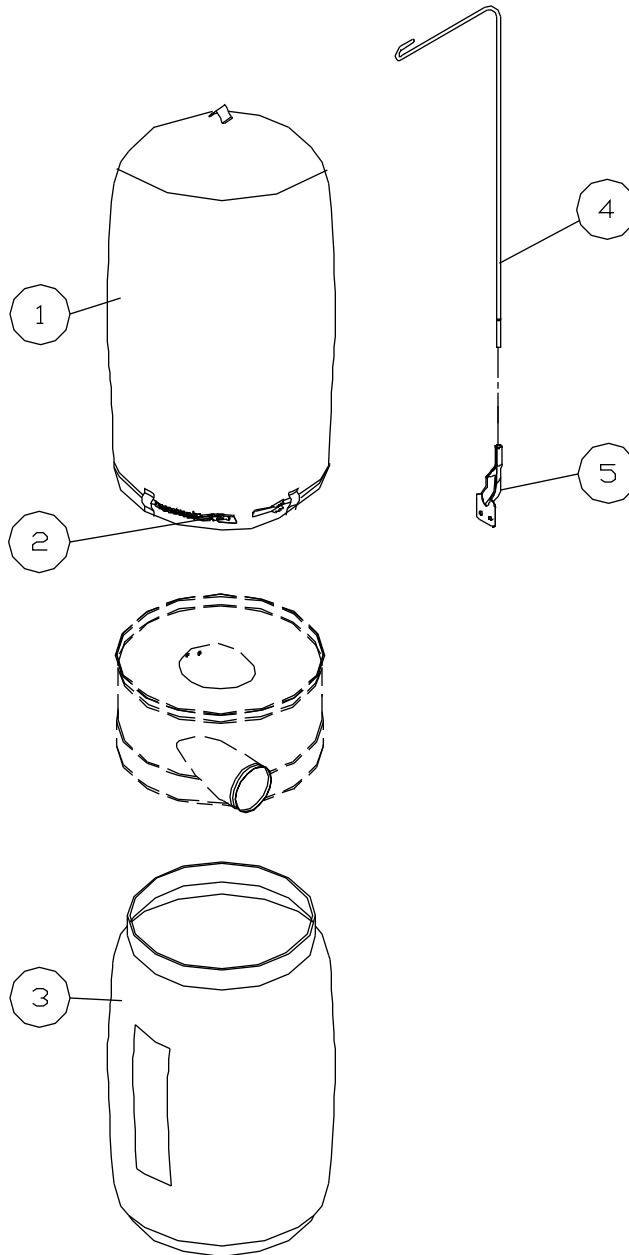

5-Micron Filter Bag Kit (708636MF) *Optional Accessory*

Index No.	Part No.	Description	Size	Qty
.....	708636MF	5-Micron Filter and Collection Bag Kit (<i>index # 1-6</i>).....		
1.....	708706.....	Filter Bag	5 Micron.....	1
2.....	AB410012	Retainer Strap.....		1
3.....	331038.....	Snap Ring.....		1
4.....	709563.....	Plastic Bag (Package of 5)		1
5.....	430038.....	Hanger		1
6.....	523011W	Hanger Bracket		1

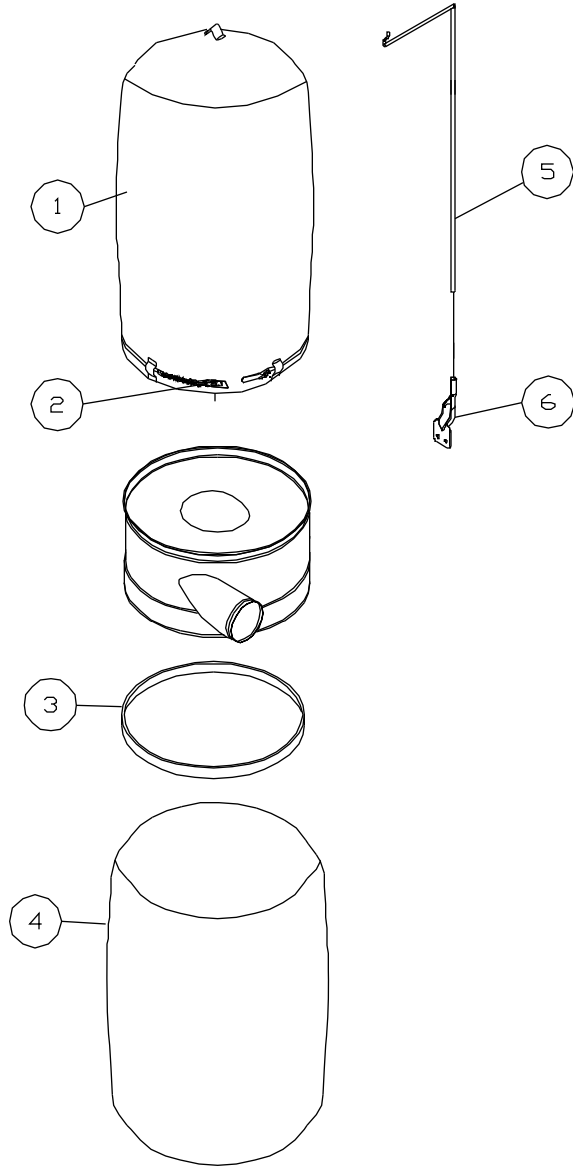

Wiring Diagram For 3 Phase 230/460V Dust Collector (DC-1200VX)

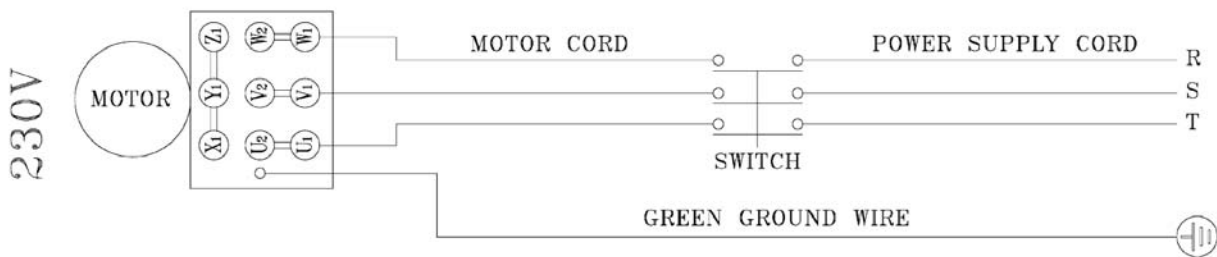
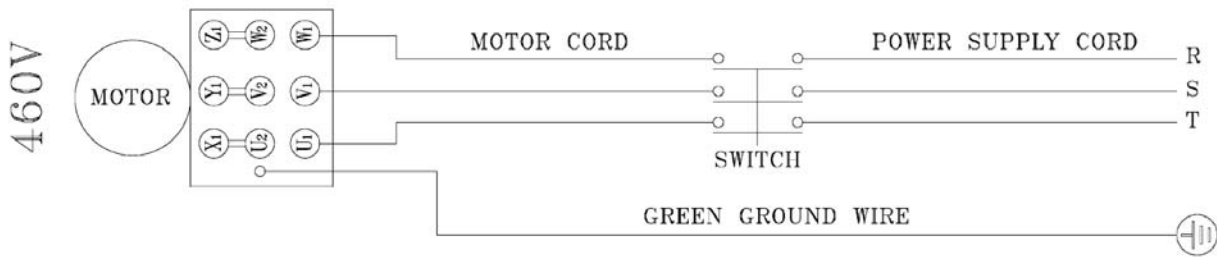

Wiring Diagram For Single Phase 230V Only Dust Collector (DC-1200VX)

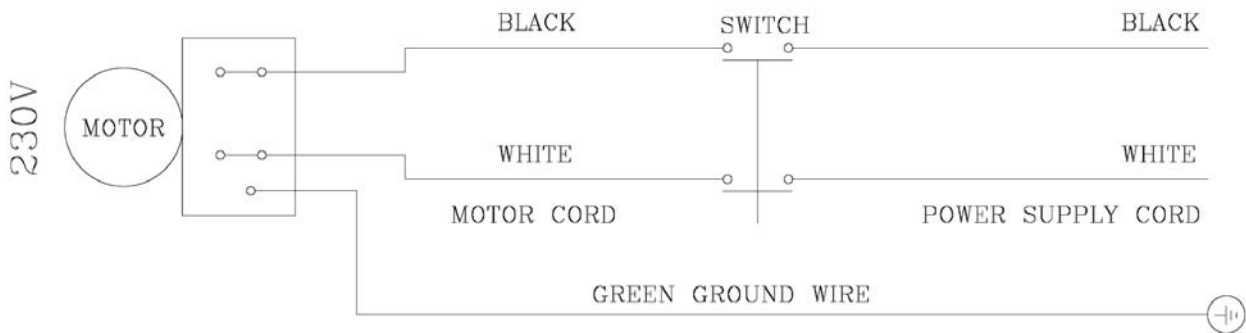



WALTER MEIER (Manufacturing) Inc.

427 New Sanford Road
LaVergne, Tennessee 37086
Phone: 800-274-6848
www.waltermeier.com