

CROSS / CUT Mod.4108 A

01.07.2017

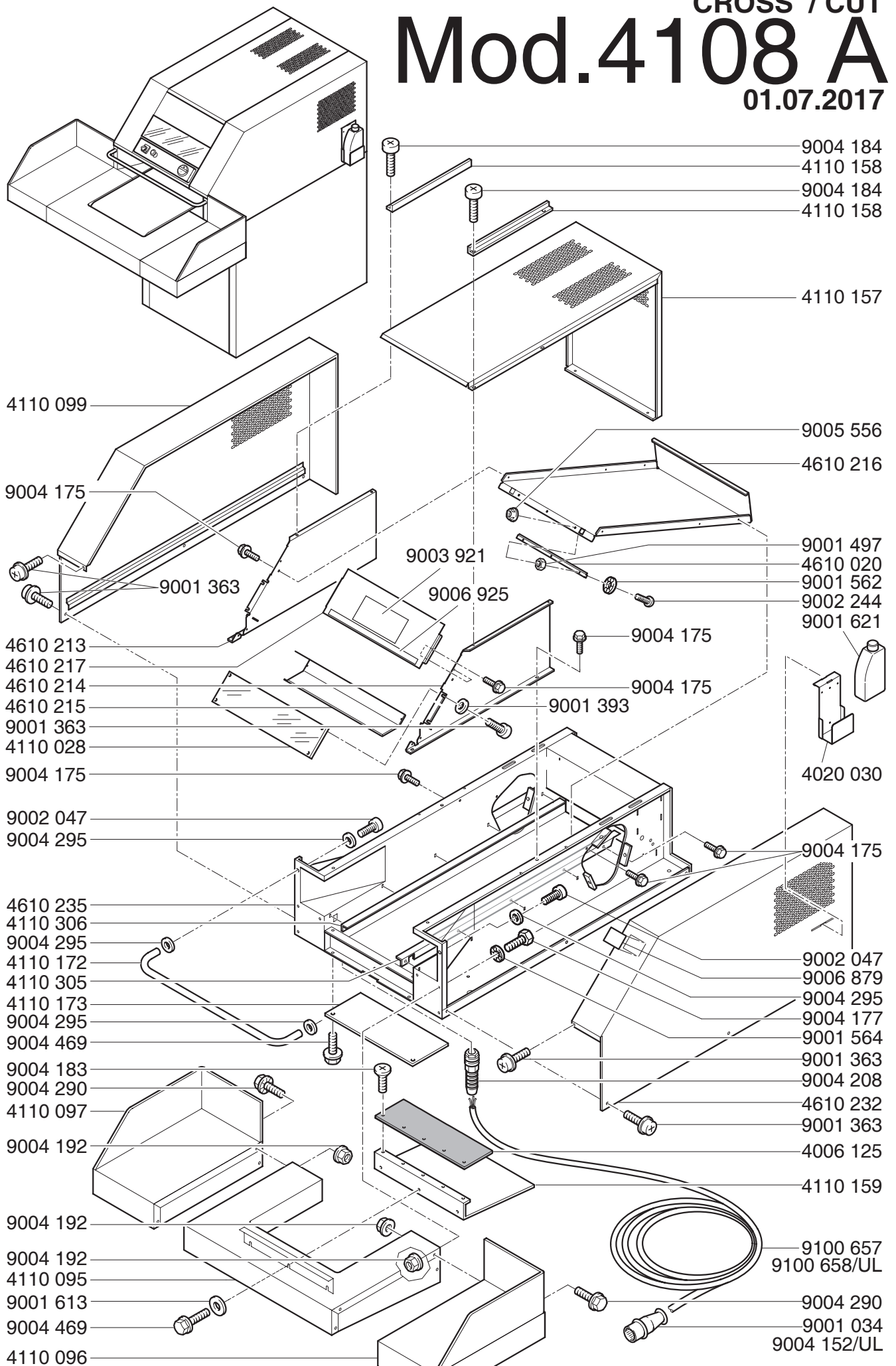

CROSS / CUT Mod.4108 A

01.07.2017

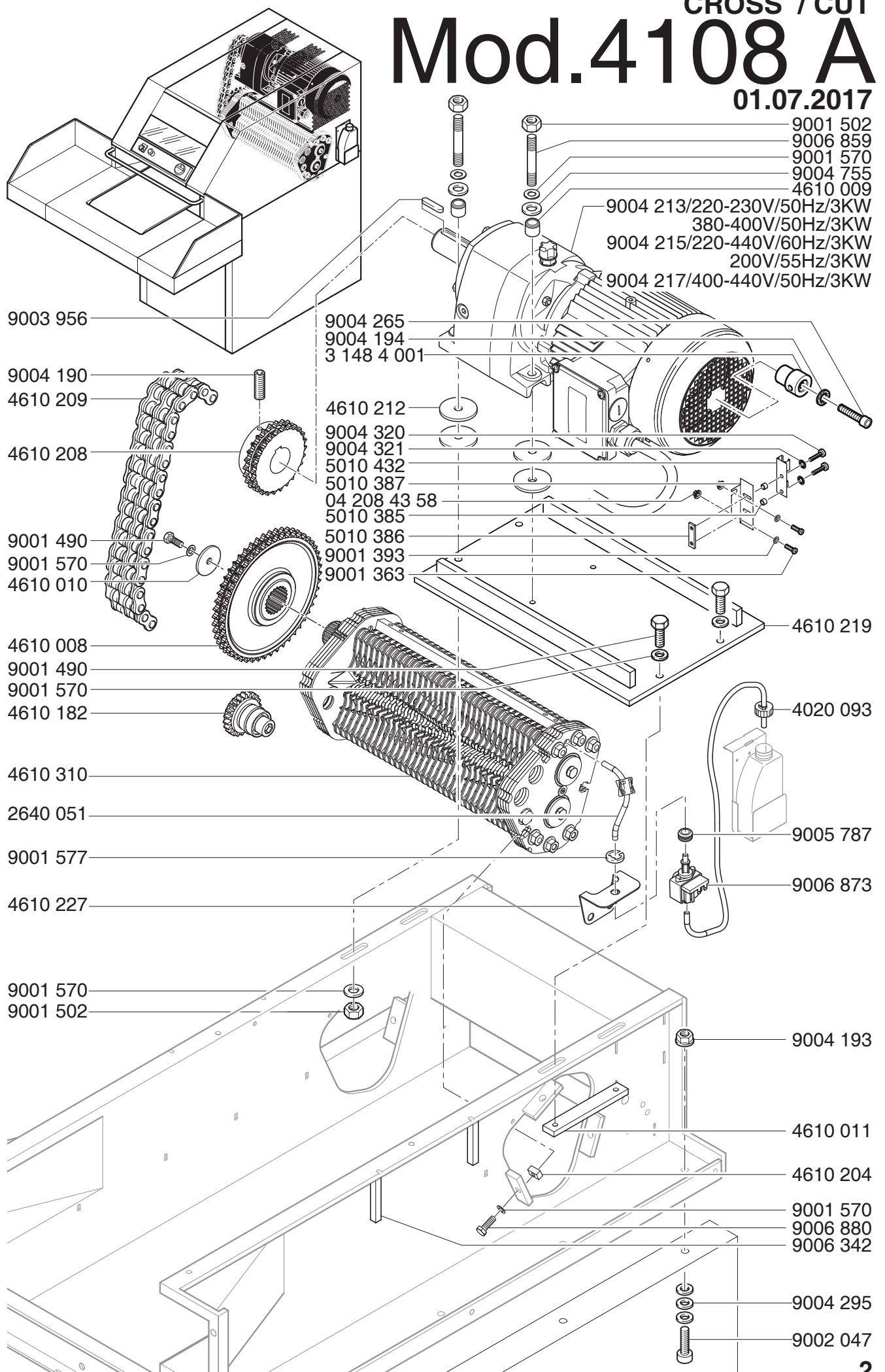

CROSS / CUT Mod.4108 A

19.03.2018

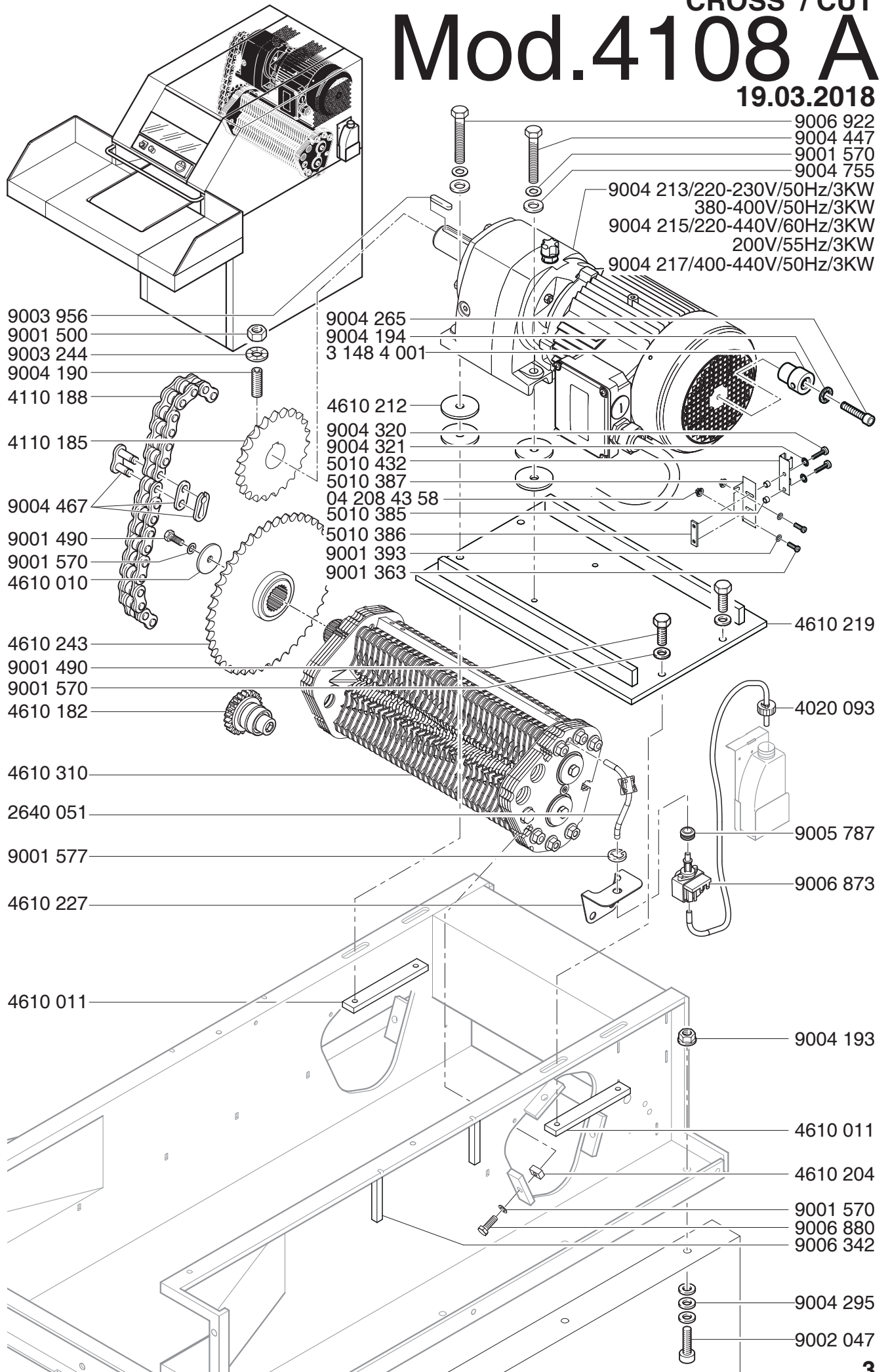

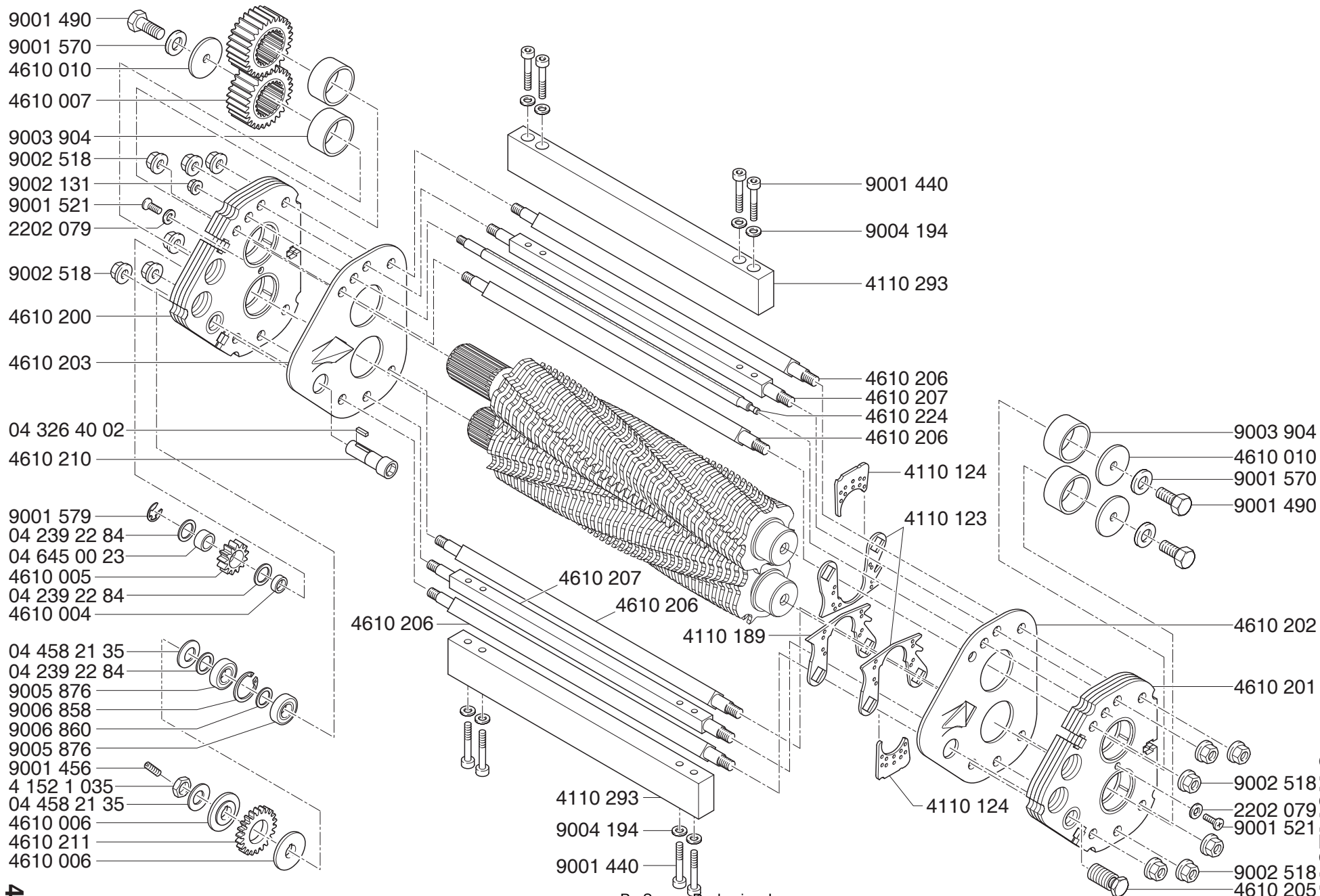

Mod. 4108 A
 CROSS / CUT
 01.07.2017

CROSS / CUT
Mod.4108 A
 01.07.2017

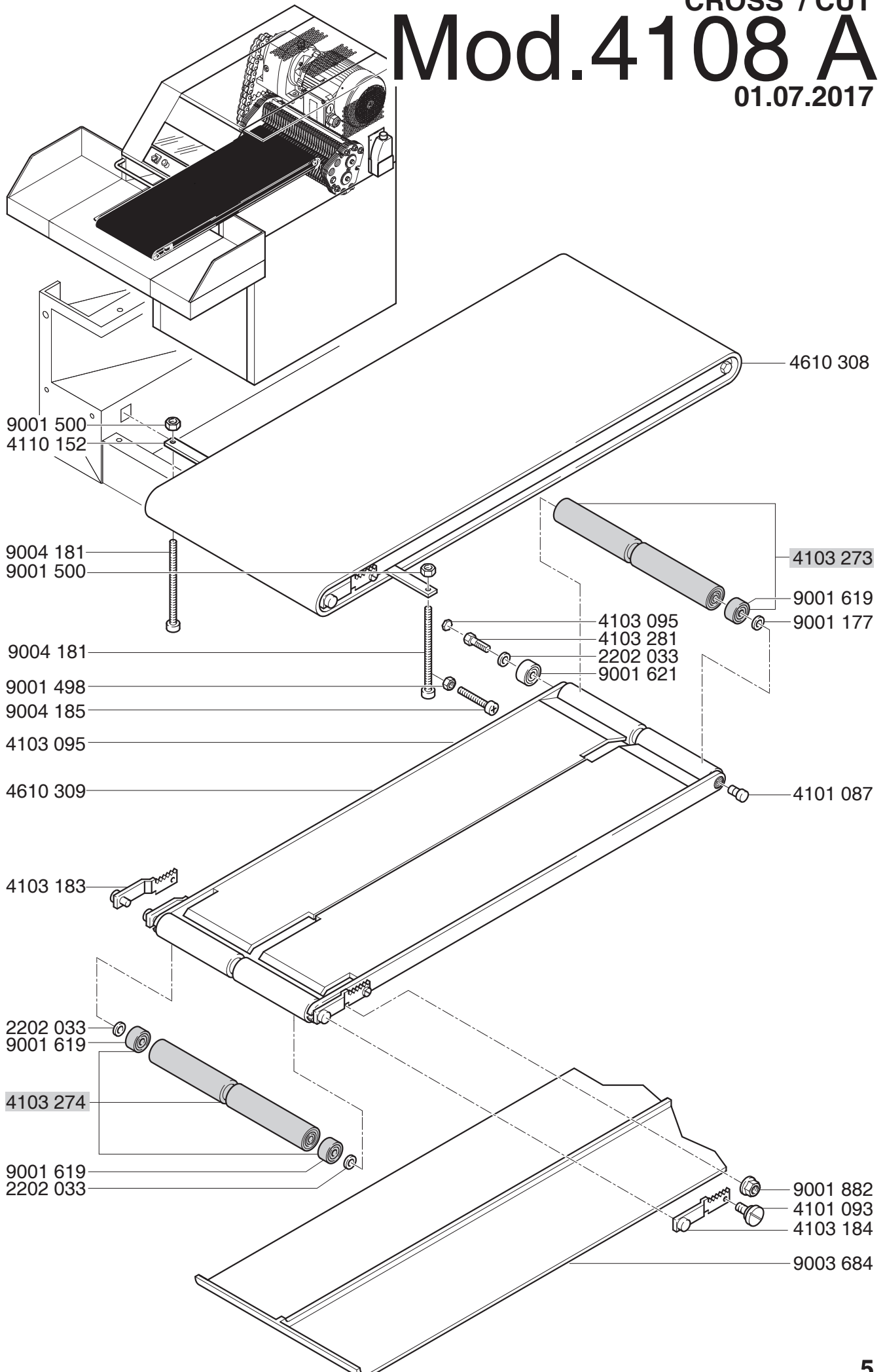

CROSS / CUT
Mod.4108 A
 01.07.2017

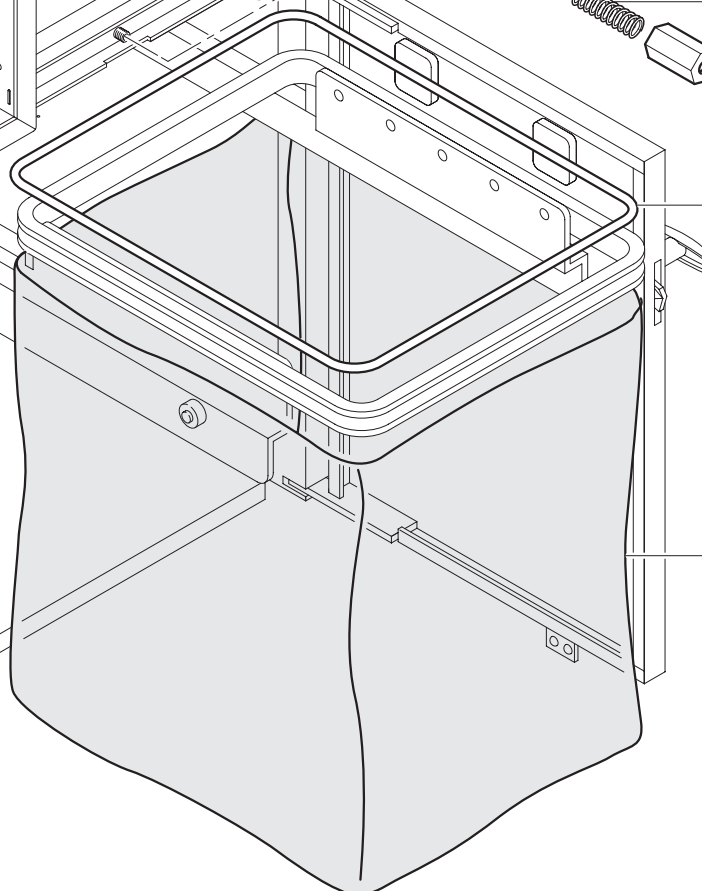
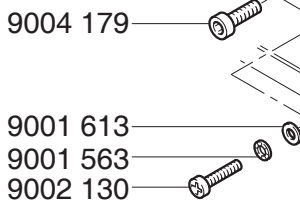
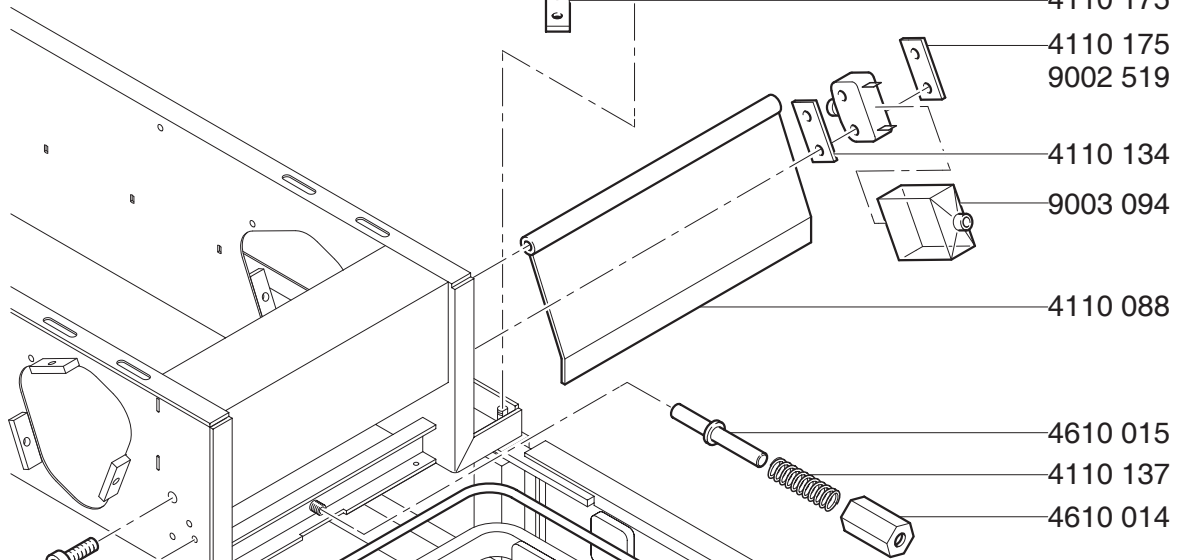
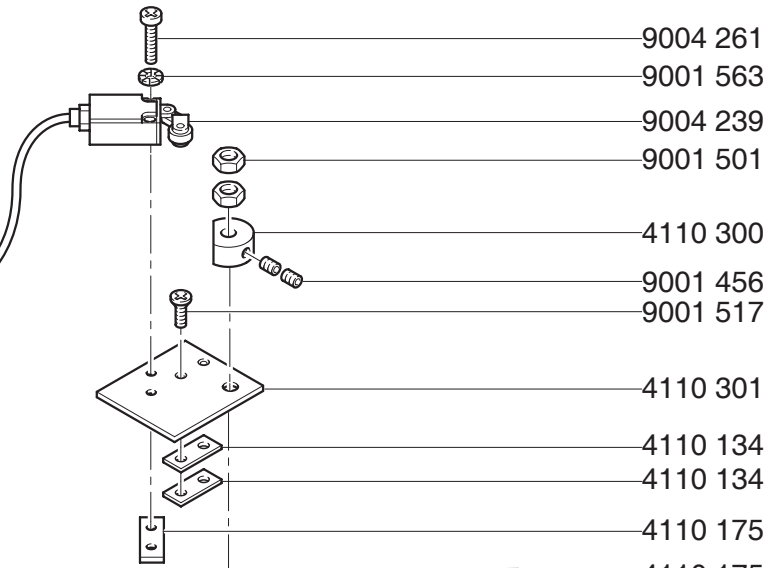
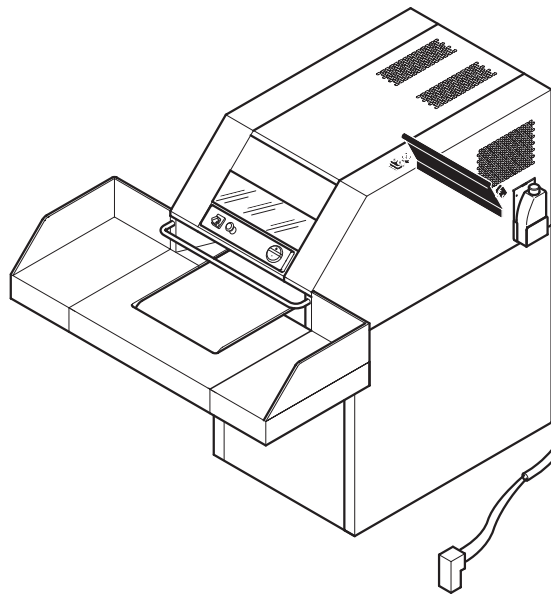

- 9004 261
- 9001 563
- 9004 239
- 9001 501
- 4110 300
- 9001 456
- 9001 517
- 4110 301
- 4110 134
- 4110 134
- 4110 175
- 4110 175
- 9002 519
- 4110 134
- 9003 094
- 4110 088
- 4610 015
- 4110 137
- 4610 014
- 4110 171
- 9000 412

CROSS / CUT Mod.4108 A

01.07.2017

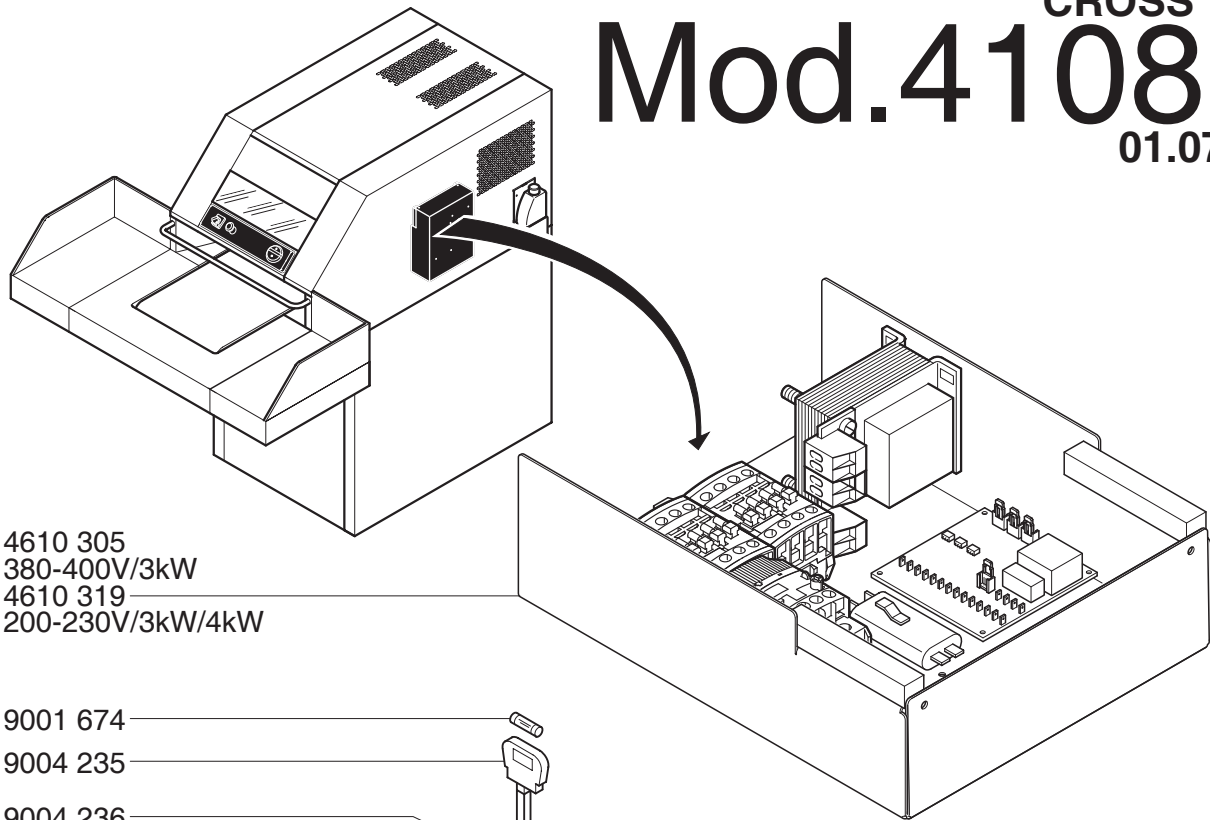

4610 305
380-400V/3kW
4610 319
200-230V/3kW/4kW

9001 674

9004 235

9004 236

9006 141

9006 141

9006 144

380-400V/3kW

9006 146

200-230V/380-400V/4kW

4610 231

4610 021

9001 913

9001 179

9003 296

9003 084

9001 563

9001 385

4610 031

04 763 00 20

9006 342

9001 961

4610 229

9002 282

9004 220

9004 222

9004 221

4610 306

9004 312

9004 175

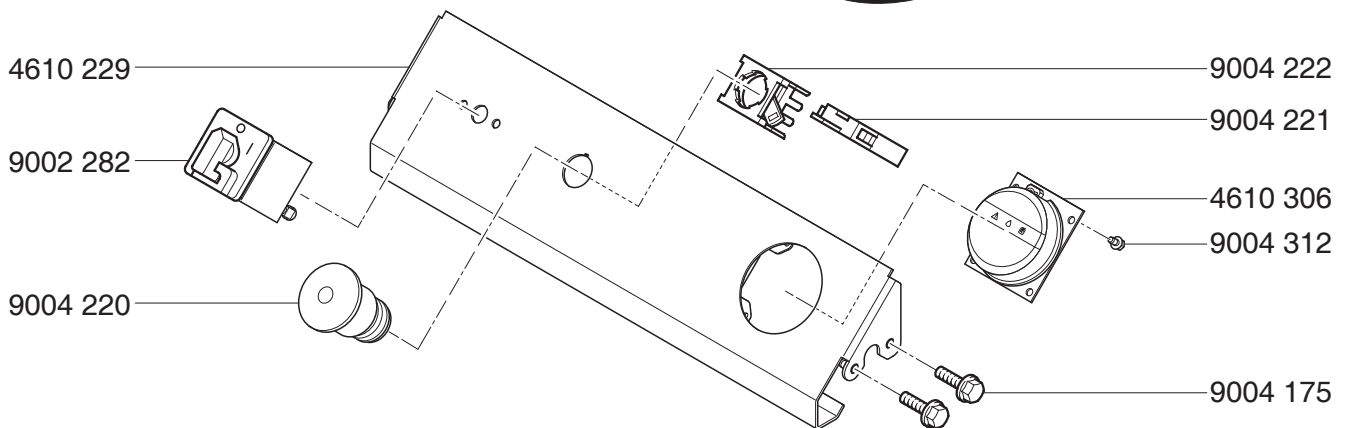

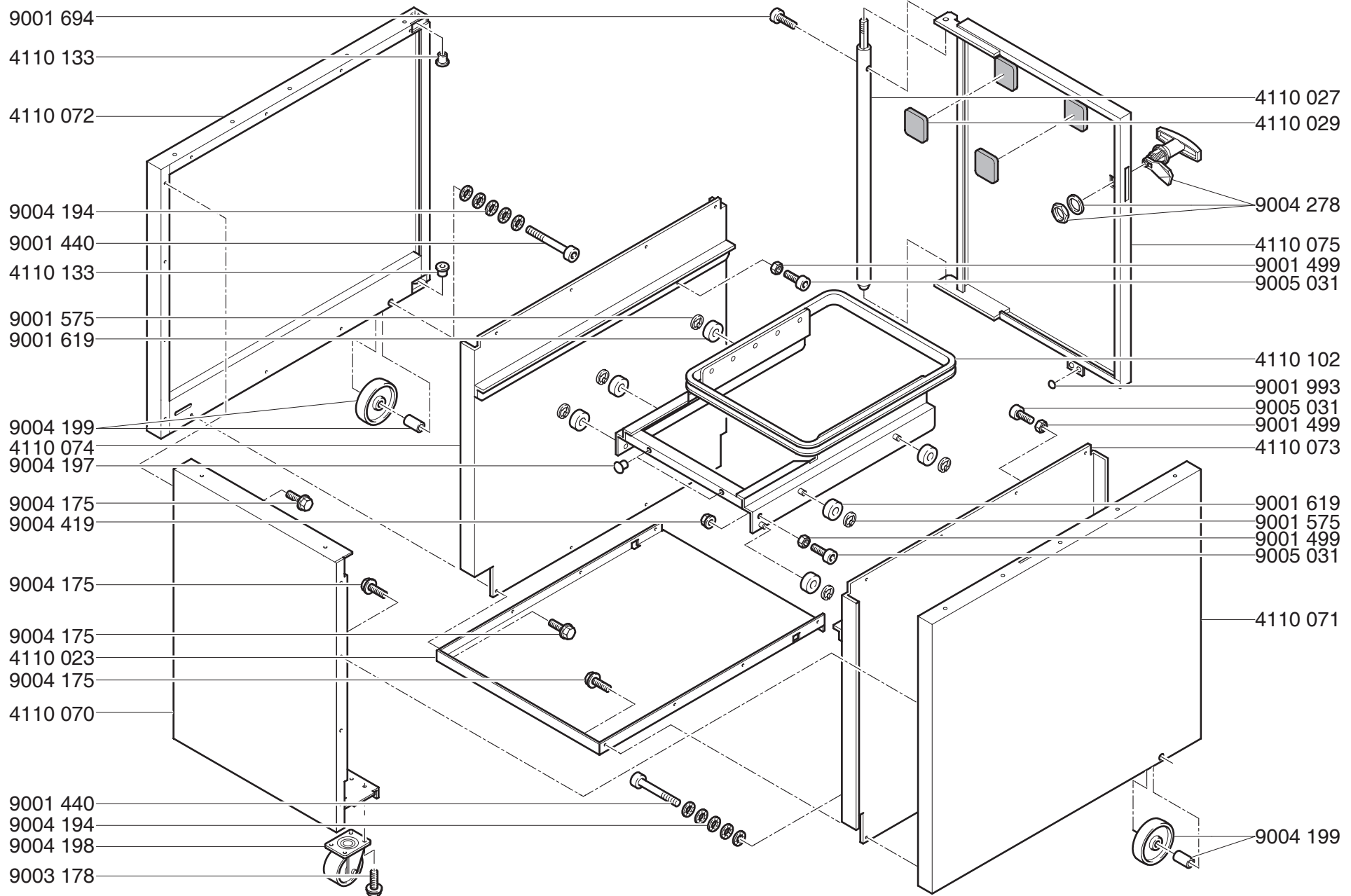

Mod. 4108 A
 CROSS / CUT
 01.07.2017

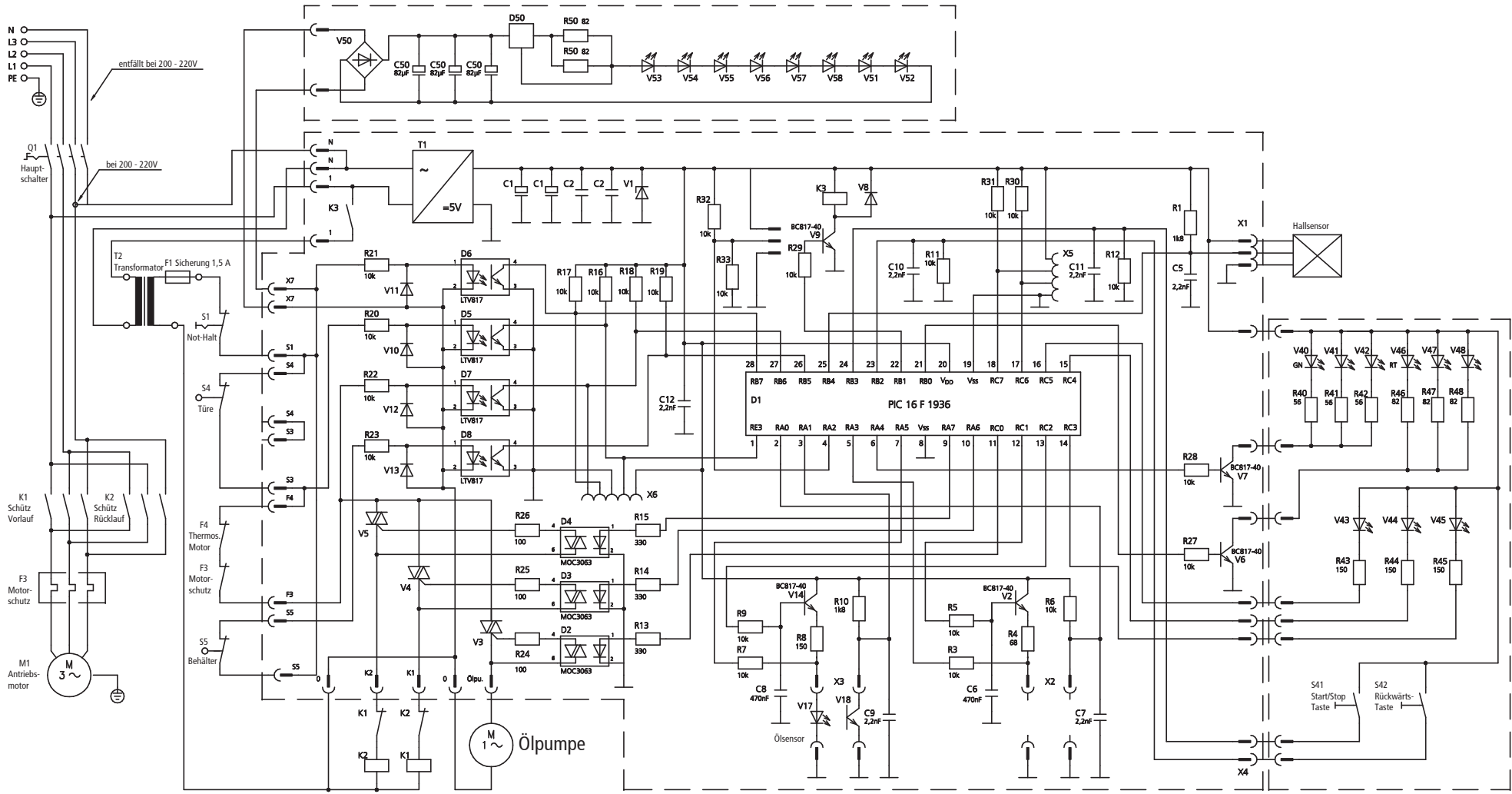

Mod. 4108 A
 CROSS / CUT
 01.07.2017

Index 4108 A

Code	Deutsch	English	Français	Nederlands	Italiano	Español
A1	Platine Steuerung	PCB control	Platine de commande	Stuurprintplaat	Scheda controllo	Placa de control
A2	Bedienplatine	PCB programming	Platine de programmation	Printplaat zadelmotor sturing	Scheda di programmazione	Placa de programación
A3	Beleuchtung	Illumination	L'illumination	Verlichting	L'illuminazione	La iluminación
F1	Sicherung 1,5 A	Fuse 1,5 A	Fusible 1,5 A	Zekering 1,5 A	Fusible 1,5 A	Fusible 1,5 A
F3	Motorschutz	Motor protection	Protection du moteur	Motorbeveiliging	Il salvamotore	Protección de motor
F4	Thermosicher., Motor	Thermal Fuse, Motor	Fusible, Moteur	Thermische zekering motor	Fusibile, motore	Fusible, Motor
K1	Schütz Vorlauf	Relay forwards	Contacteur marche avant	Relais vooruit	Relé marcia avanti	Relé de marche adelante
K2	Schütz Rücklauf	Relay reverse	Contacteur marche Arrière	Relais terugloop	Relé marcia indietro	Relé de retroceso
M1	Antriebsmotor	Motor	Moteur	Aandrijf motor	Motore	Motor
Q1	Hauptschalter	Main switch	Interrupteur principal	Hoofdschakelaar	Interruttore principale	Interruptor principal
S1	Not-Halt Taste	Emergency Stop	Arrêt d'urgence	Noodstop	Arresto di emergenza	Parada de emergencia
S4	Sicherheitsschalter Türe	Safety switch door	Micro-contact rampe de sécurité	Veiligheidsschakelaar (deur)	Interruttore di sicurezza dello sportello	Micro interruptor de seguridad puerta
S5	Schalter "Sack voll"	Switch "bag full"	Micro-contact sac plein	Schakelaar (Zak vol)	Interruttore "sacco pieno"	Micro interruptor de "bolsa llena"
S41	Start/Stopp-Taste	Start/Stop button	Touche START/STOP	Start/stop-toets	Pulsante Start/Stop	Tecla de inicio/parada
S42	Rückwärts-Taste	Reverse button	Touche RETOUR	Achteruit-toets	Pulsante Indietro	Tecla de retroceso
T2	Transformator	Transformer	Transformateur	Transformator	Trasformatore	Transformador