

Mod.4002 B

01.10.2006

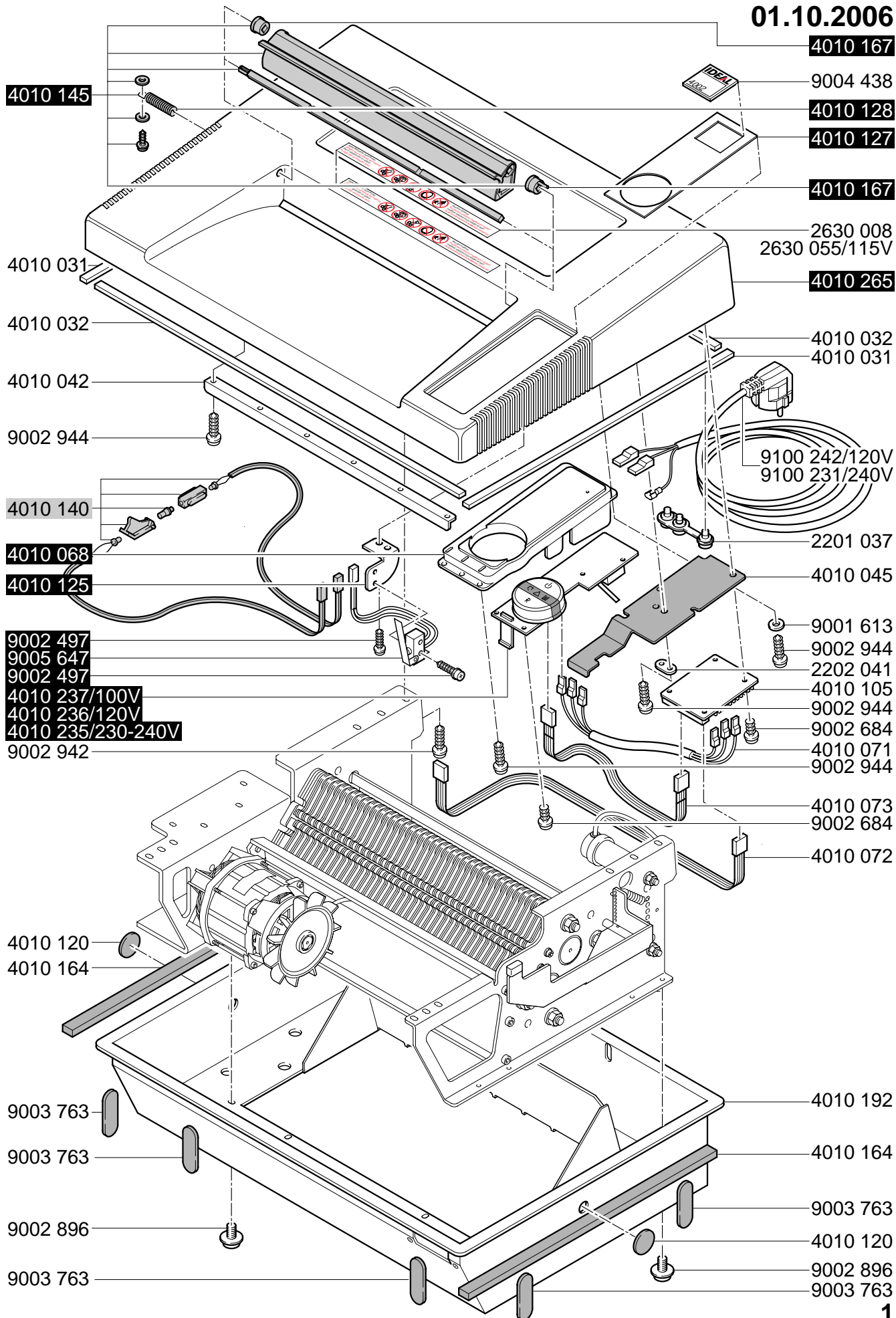

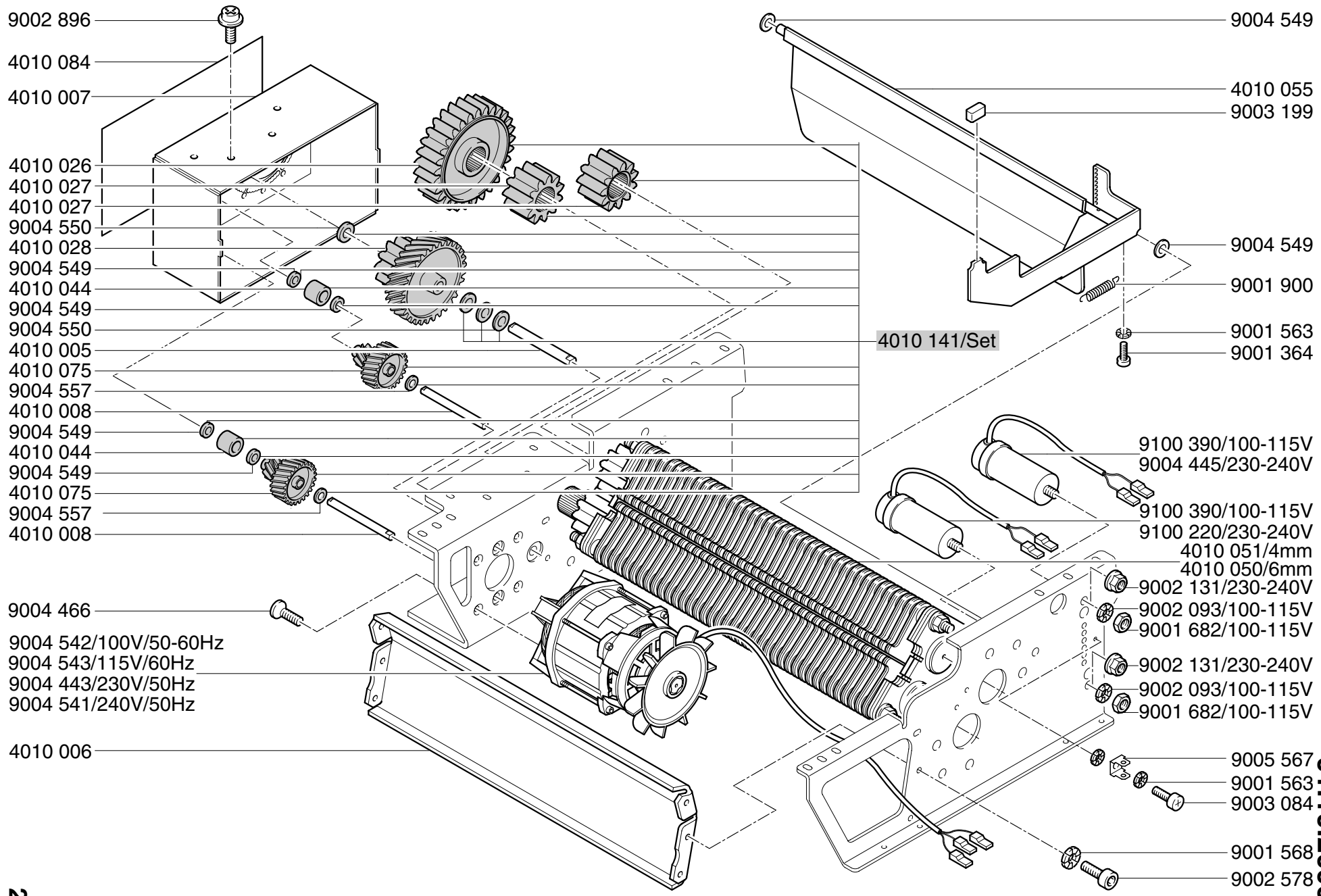

- 9002 896
- 4010 084
- 4010 007
- 4010 026
- 4010 027
- 4010 027
- 9004 550
- 4010 028
- 9004 549
- 4010 044
- 9004 549
- 9004 550
- 4010 005
- 4010 075
- 9004 557
- 4010 008
- 9004 549
- 4010 044
- 9004 549
- 4010 075
- 9004 557
- 4010 008
- 9004 466
- 9004 542/100V/50-60Hz
- 9004 543/115V/60Hz
- 9004 443/230V/50Hz
- 9004 541/240V/50Hz
- 4010 006

- 9004 549
- 4010 055
- 9003 199
- 9004 549
- 9001 900
- 9001 563
- 9001 364

4010 141/Set

- 9100 390/100-115V
- 9004 445/230-240V
- 9100 390/100-115V
- 9100 220/230-240V
- 4010 051/4mm
- 4010 050/6mm
- 9002 131/230-240V
- 9002 093/100-115V
- 9001 682/100-115V
- 9002 131/230-240V
- 9002 093/100-115V
- 9001 682/100-115V

- 9005 567
- 9001 563
- 9003 084
- 9001 568
- 9002 578

Mod. 4002 B

01.10.2006

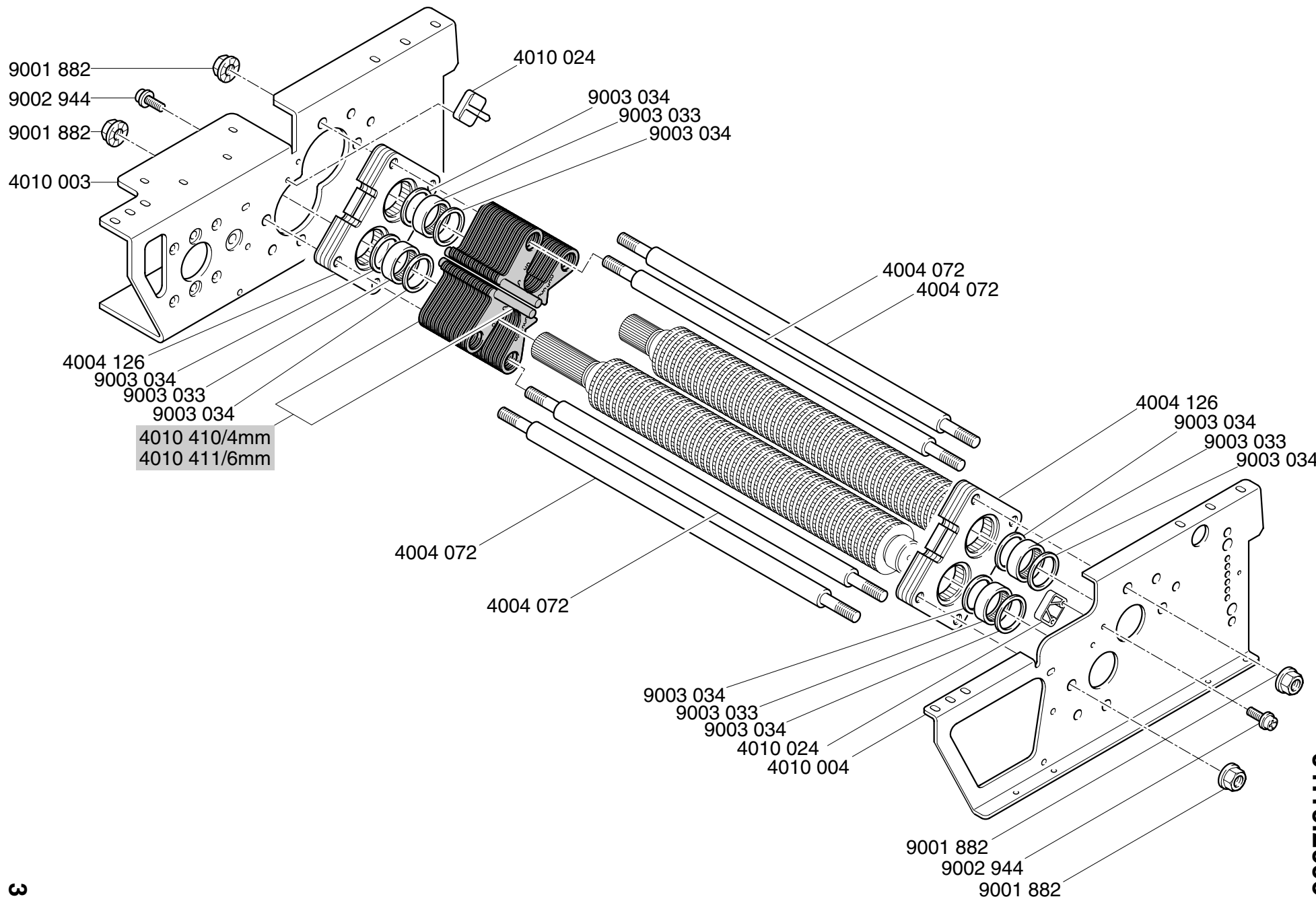

Mod. 4002 B
 01.10.2006

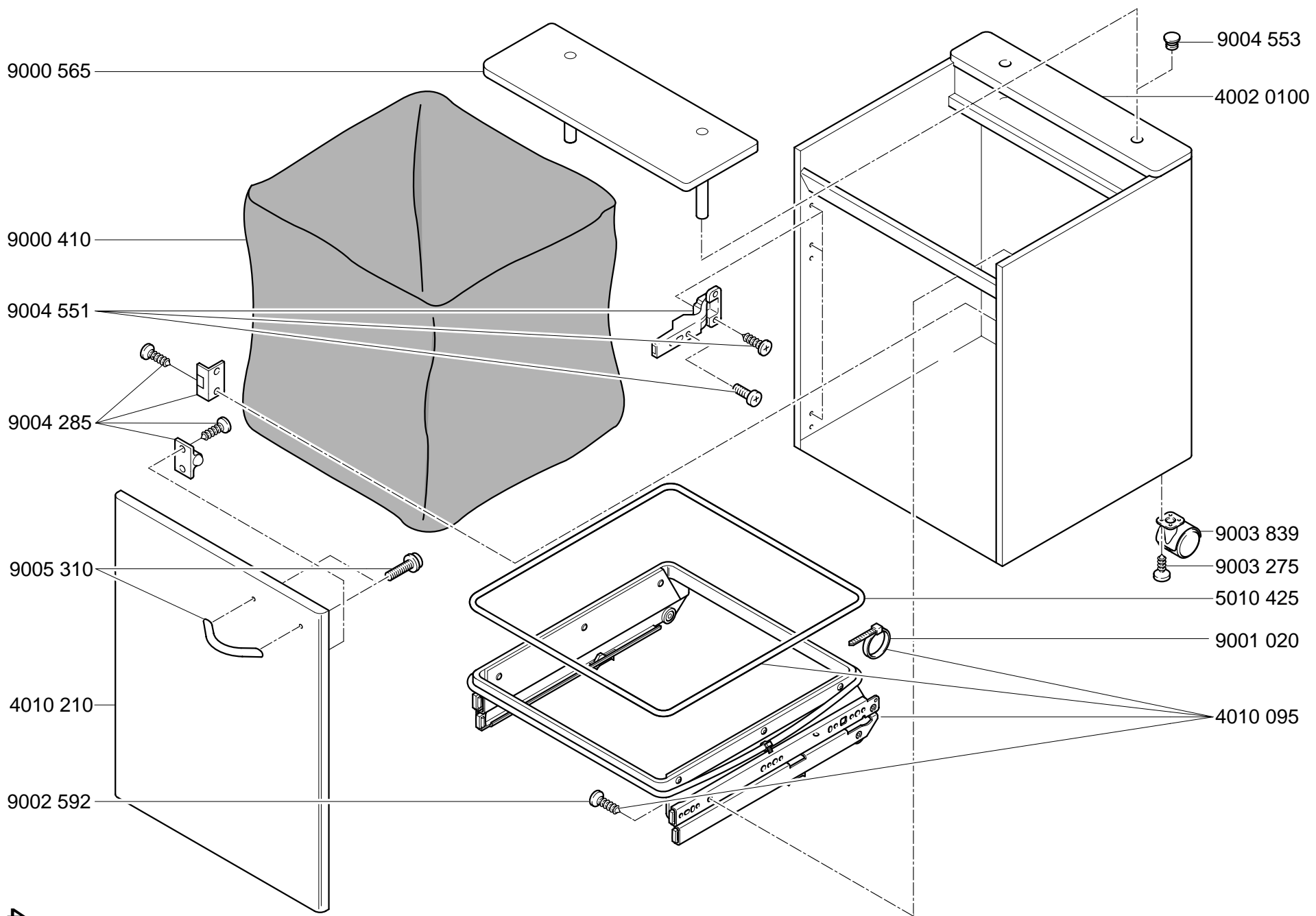

Mod. 4002 B

01.10.2006

Stromlaufplan 4002 B
 schema de
 circuit électrique 4002 B
 wiring diagram 4002 B

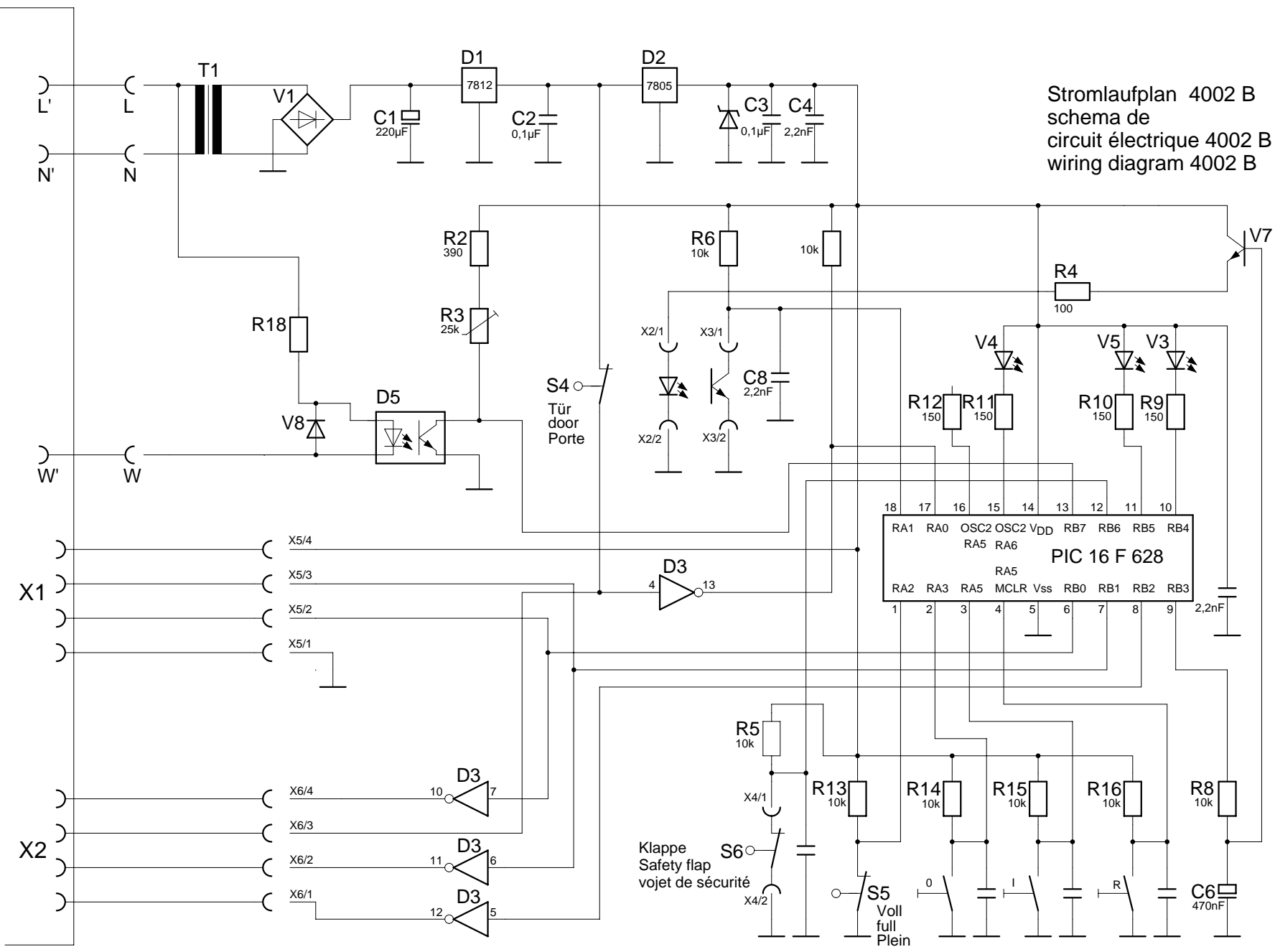

Mod. 4002 B
 01.10.2006

4010 239
5

Mod. 4002 B

01.10.2006

Anschlußplan 4002 B
 Diagramme de branchement 4002 B
 Connecting diagram 4002 B

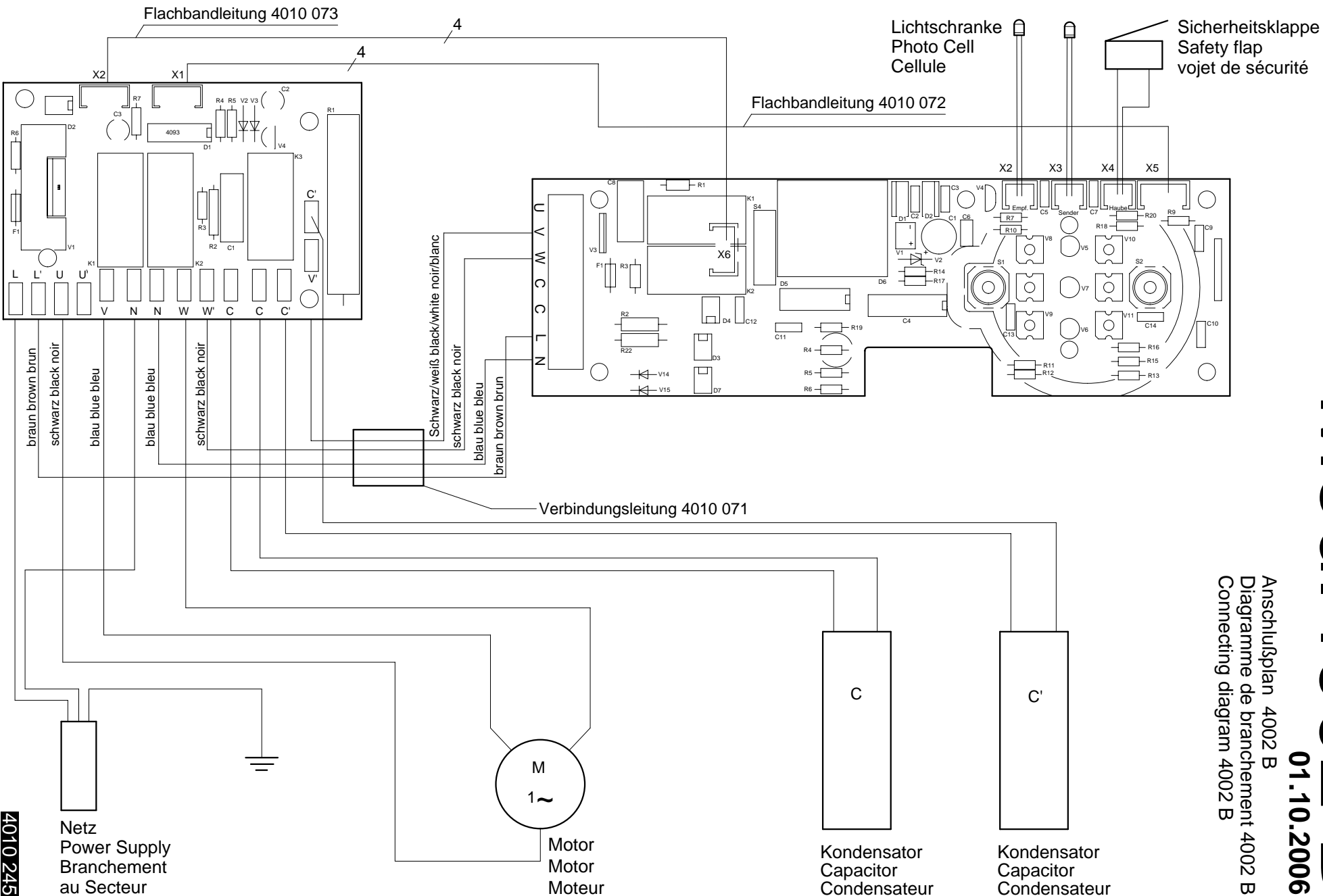

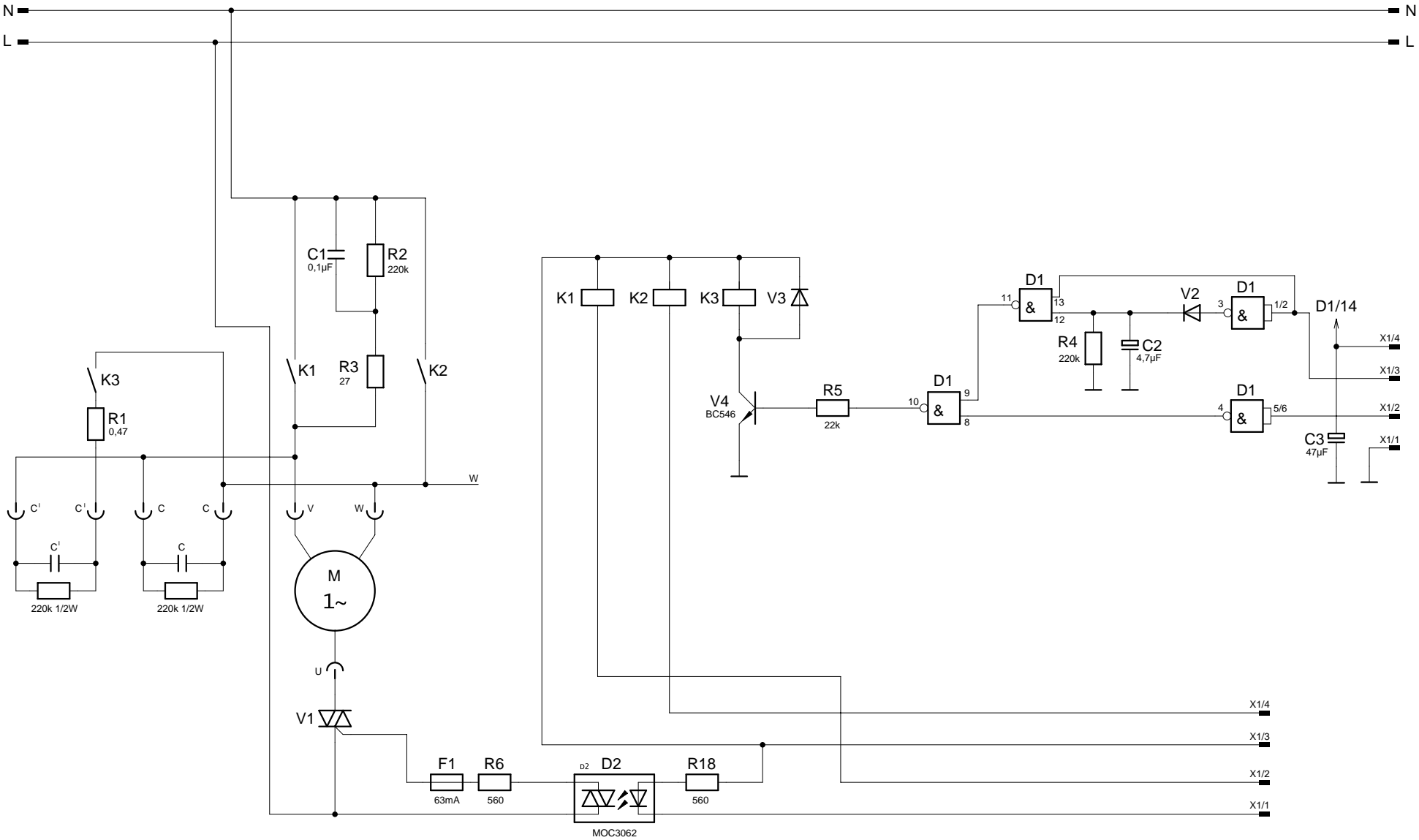

Stromlaufplan 4002 B
 schema de
 circuit électrique 4002 B
 wiring diagram 4002 B

4010 110
 7

Mod. 4002 B
 01.10.2006