

# IDEAL 5560 A

01.01.2014

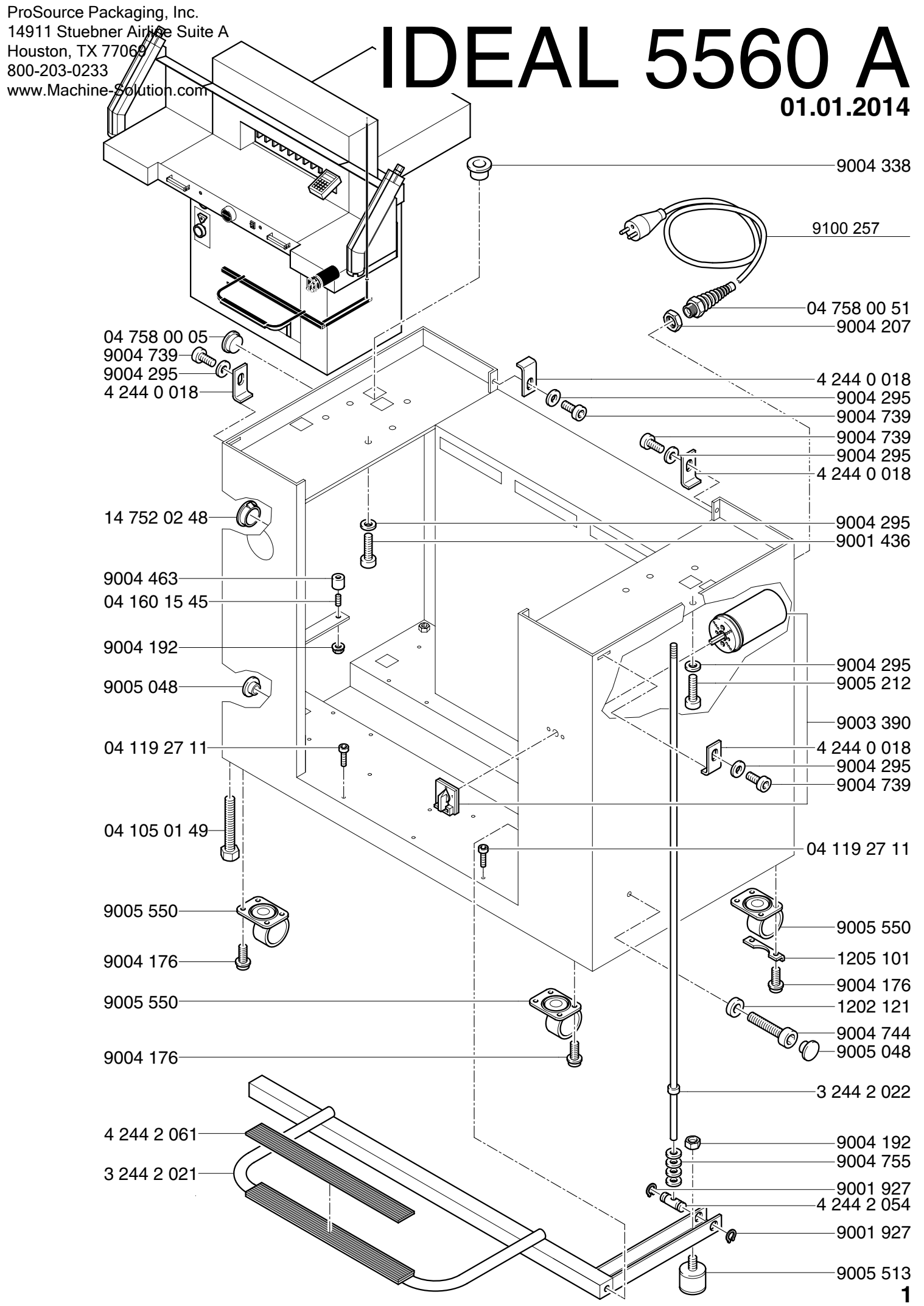

# IDEAL 5560 A

01.01.2014

14 752 05 47/115V  
14 752 05 35/230V

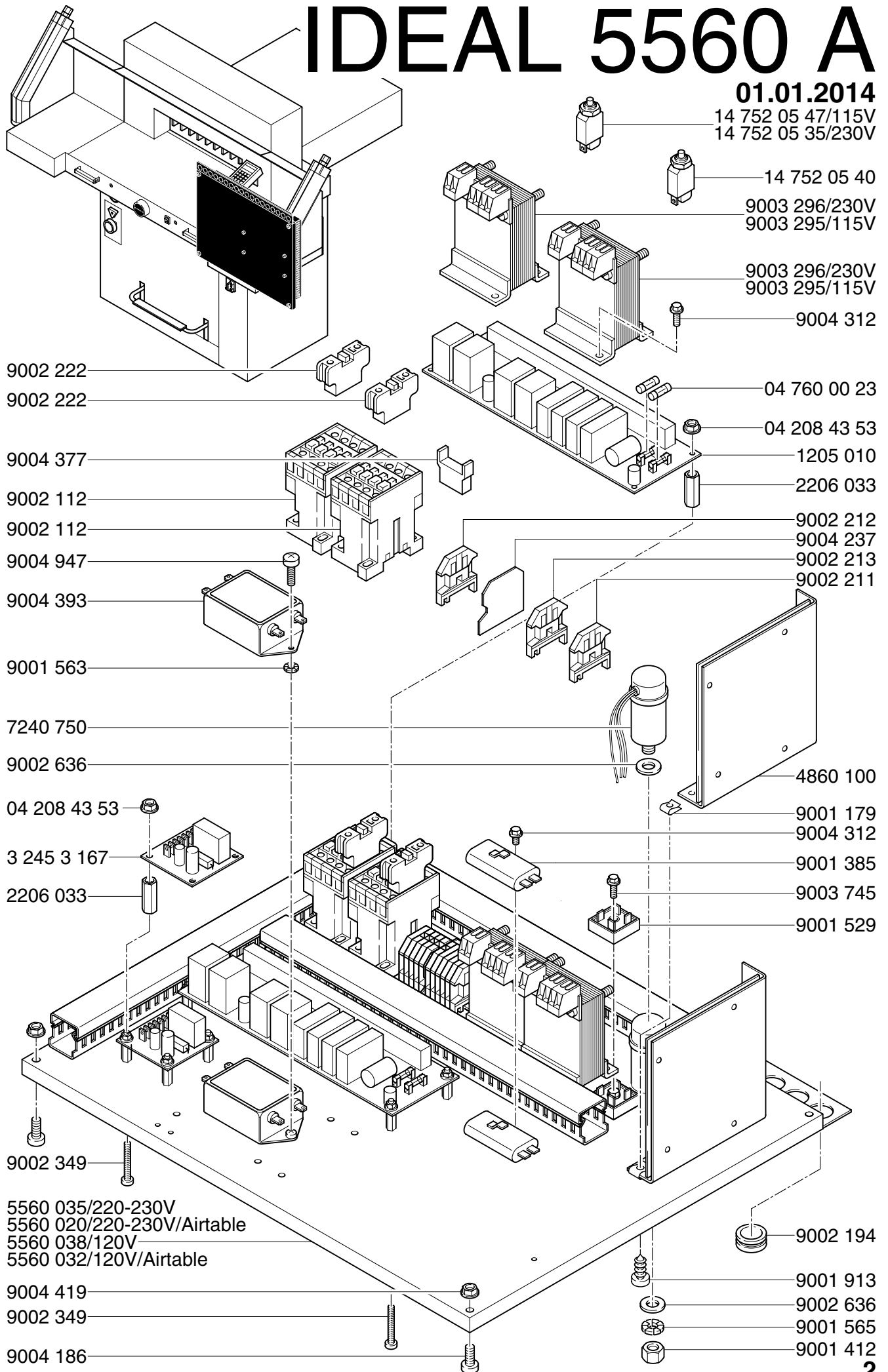

# IDEAL 5560 A

01.01.2014

14 750 02 98/230V/50Hz  
9005 501/115V/60Hz

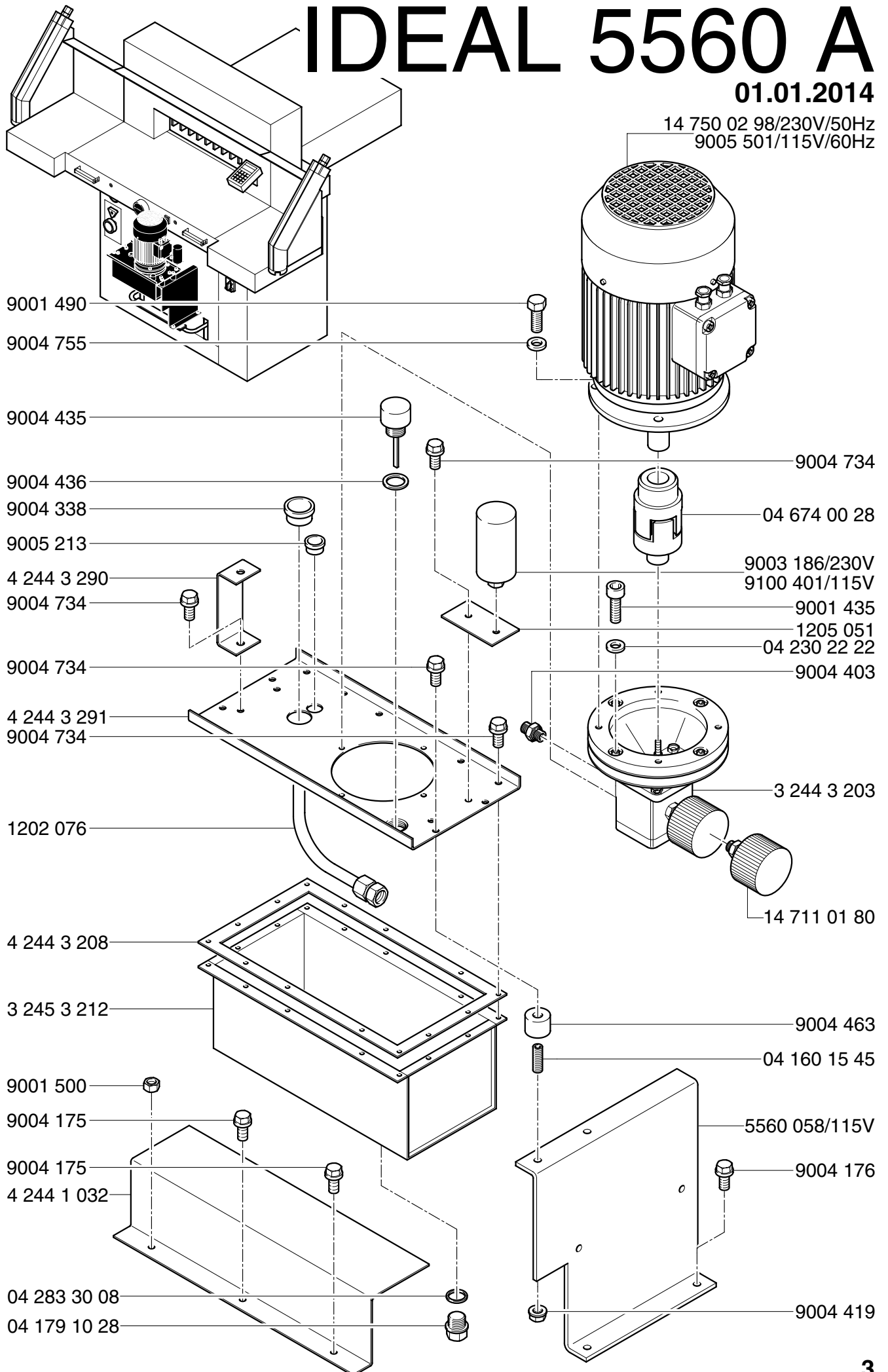

# IDEAL 5560 A

01.01.2014

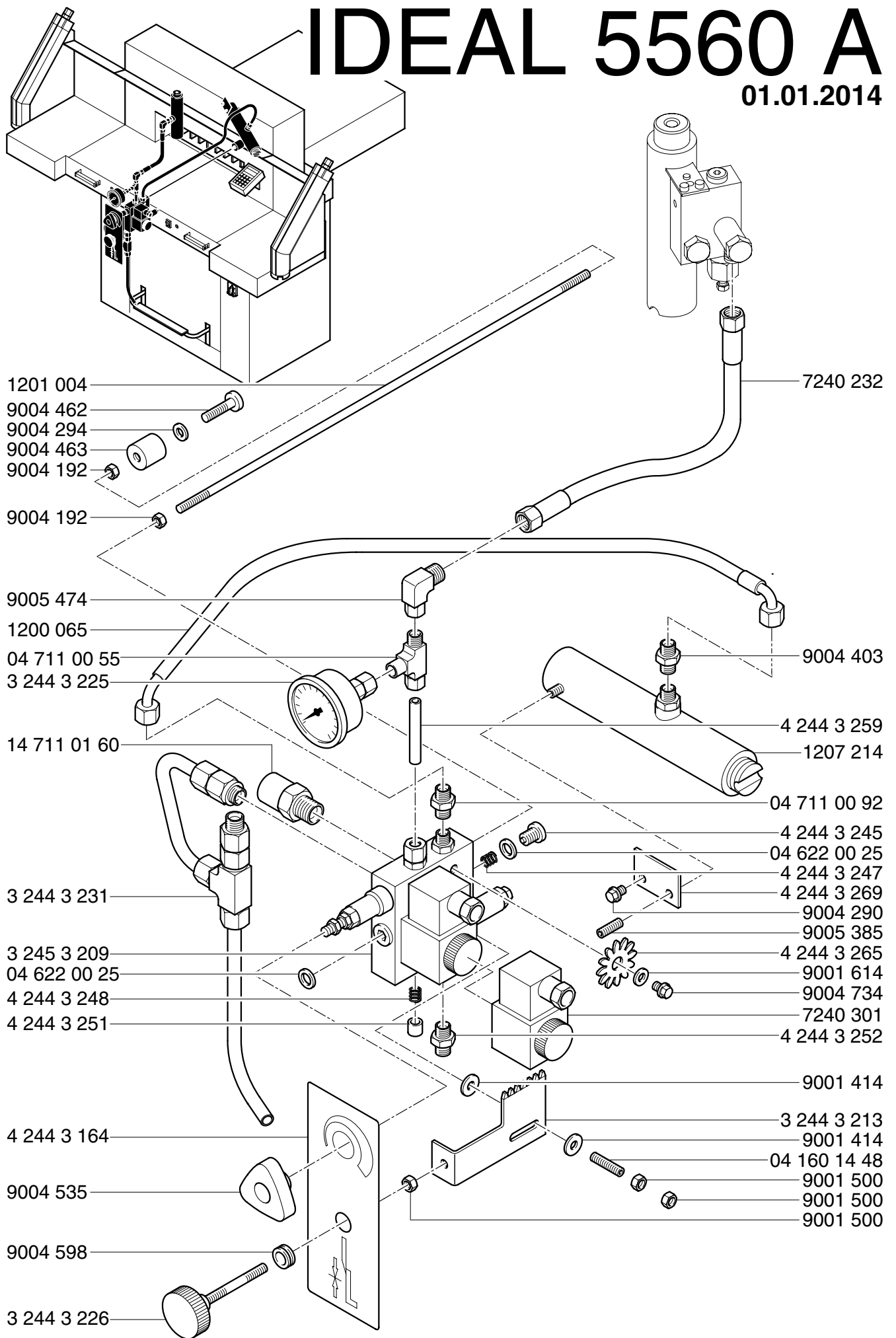

# IDEAL 5560 A

01.01.2014

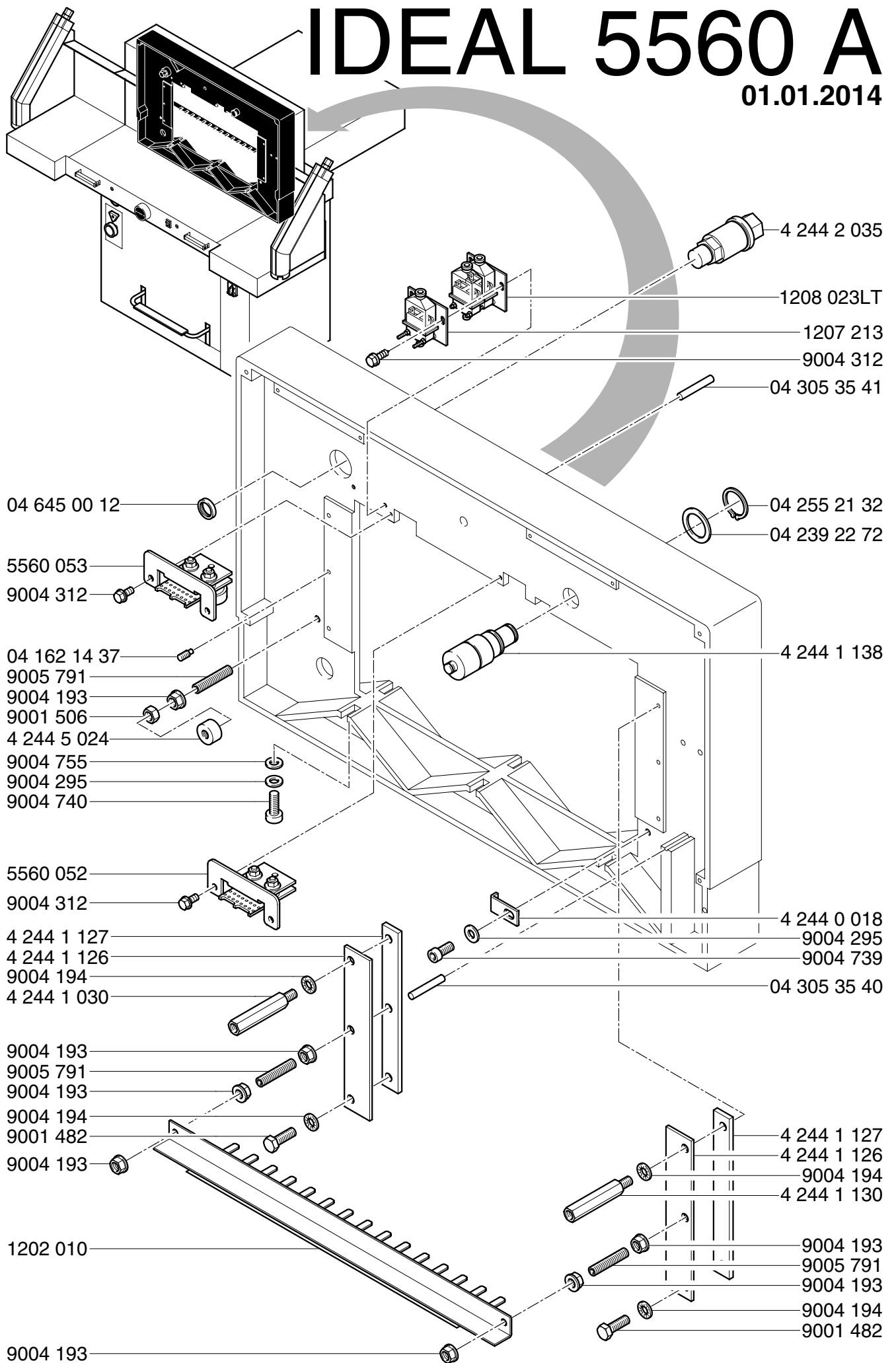

# IDEAL 5560 A

01.01.2014

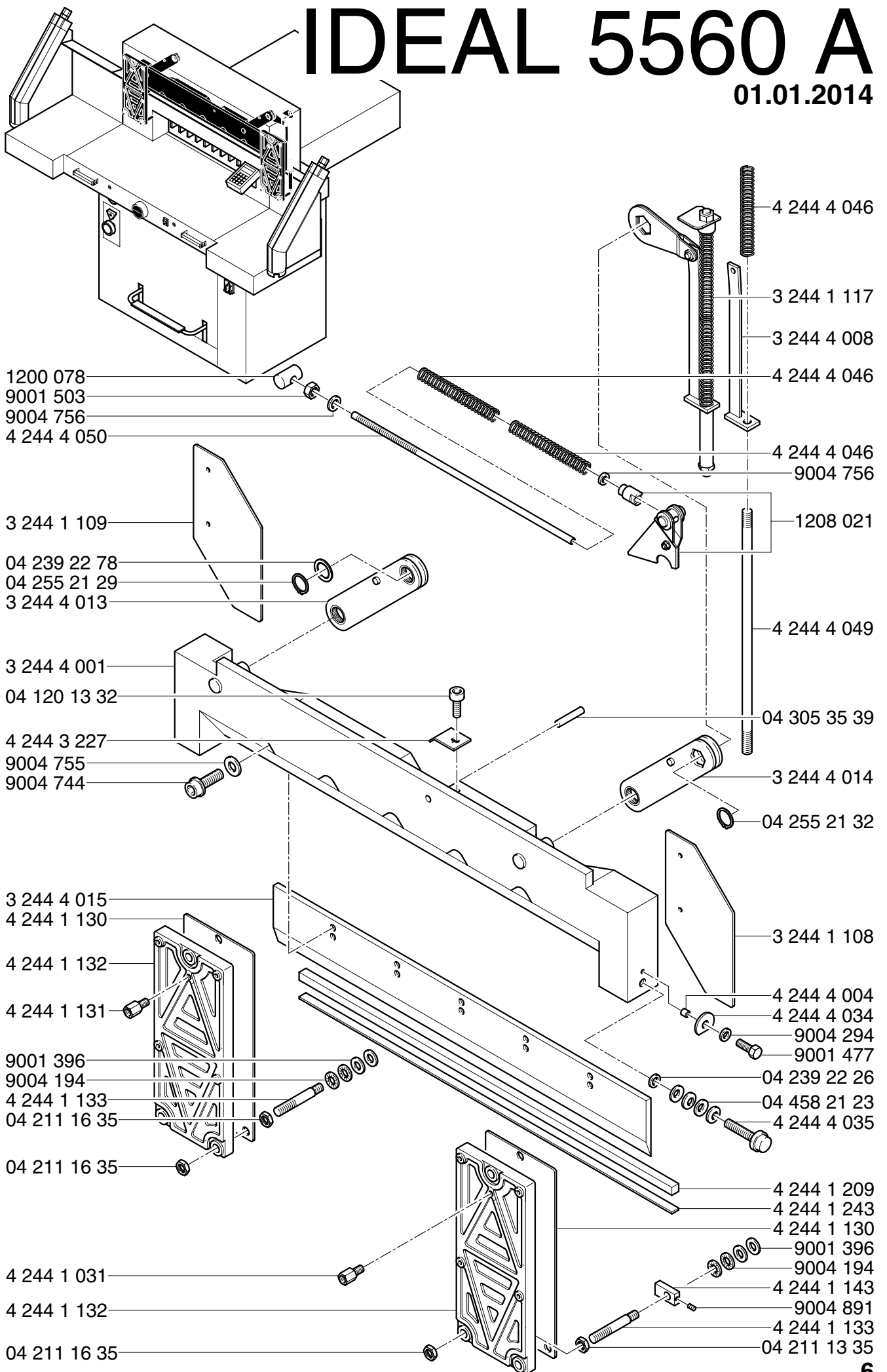

# IDEAL 5560 A

01.01.2014

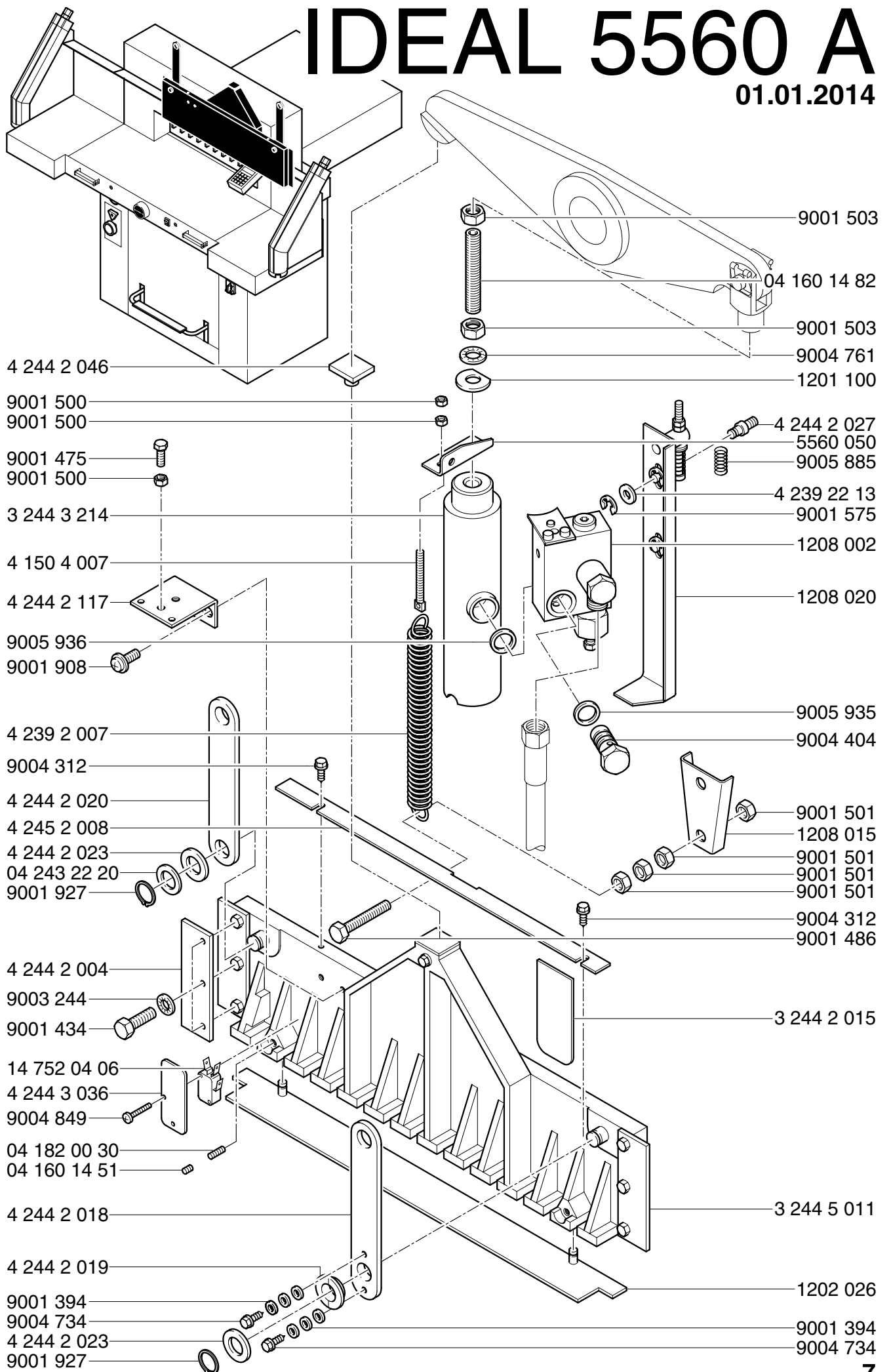

# IDEAL 5560 A

01.01.2014

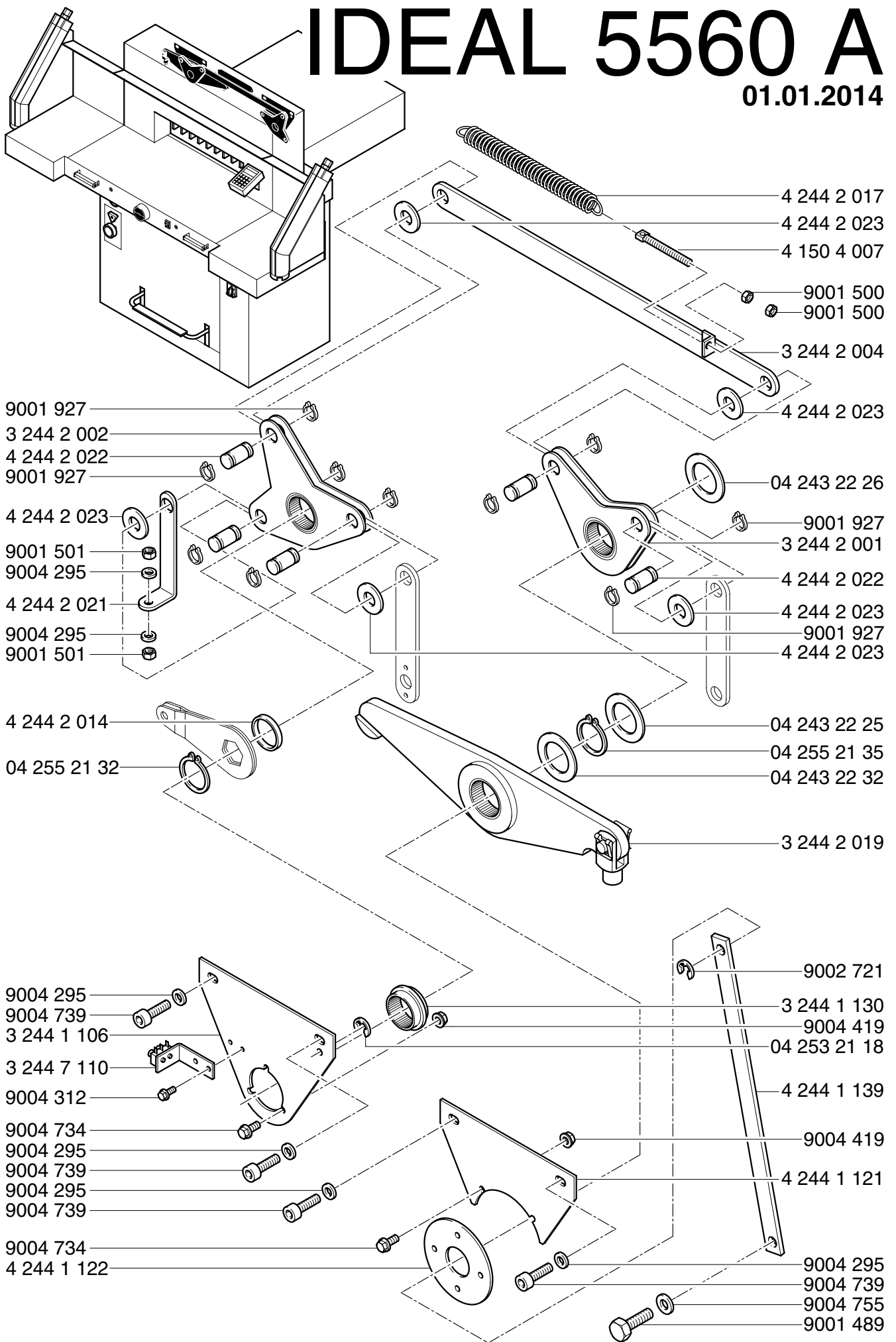



# IDEAL 5560 A

01.01.2014

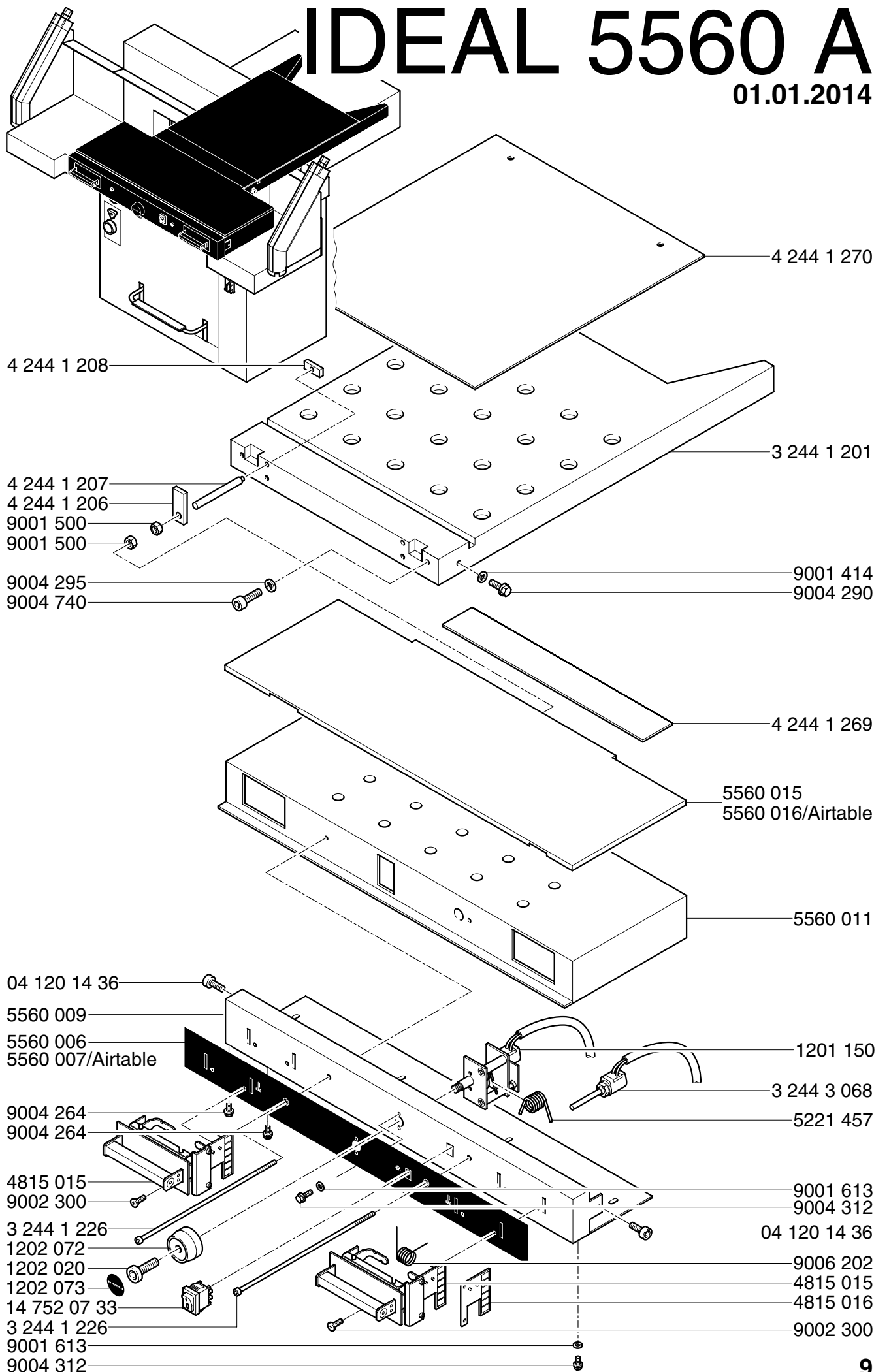

# IDEAL 5560 A

01.01.2014

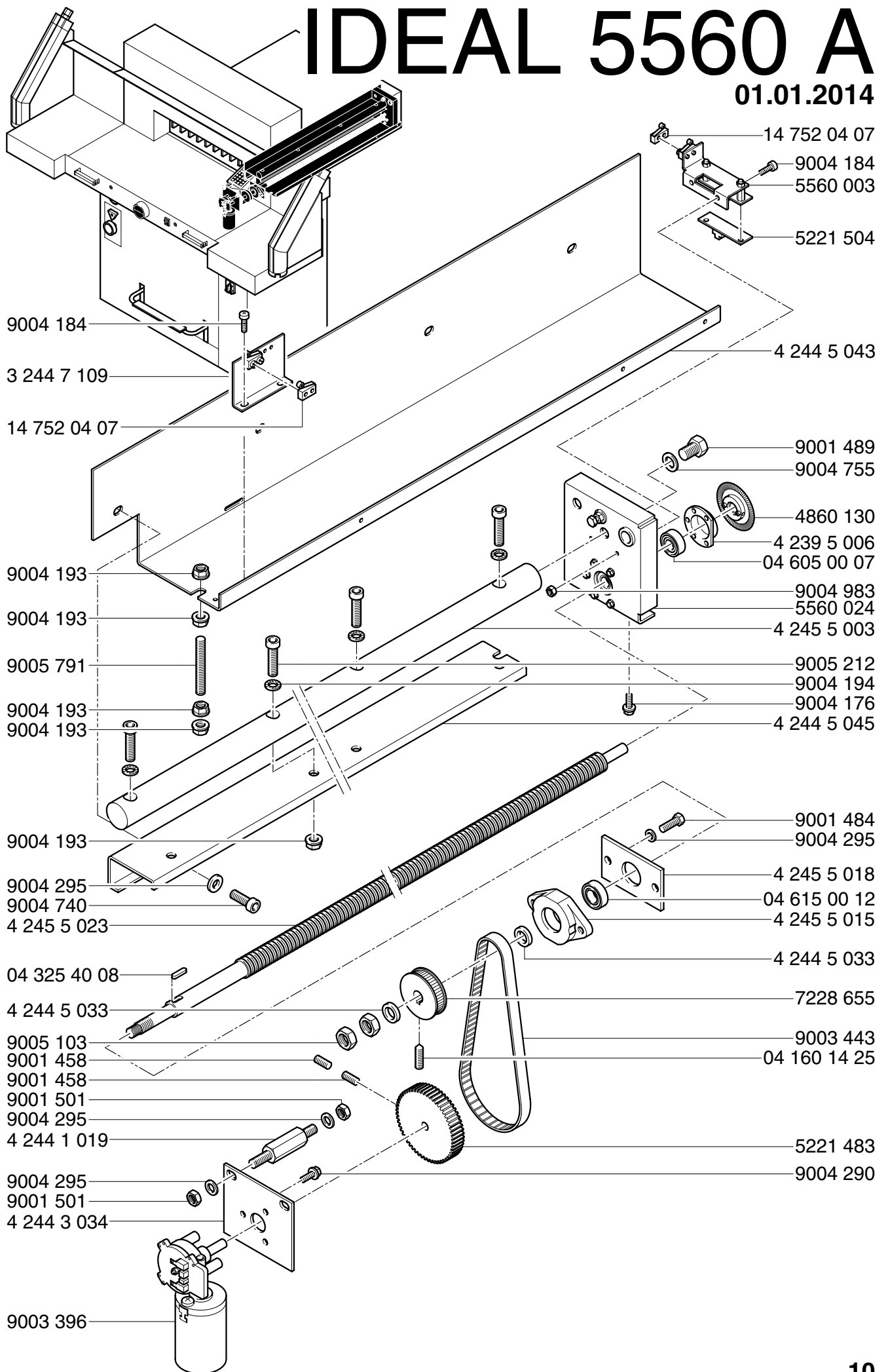

# IDEAL 5560 A

01.01.2014

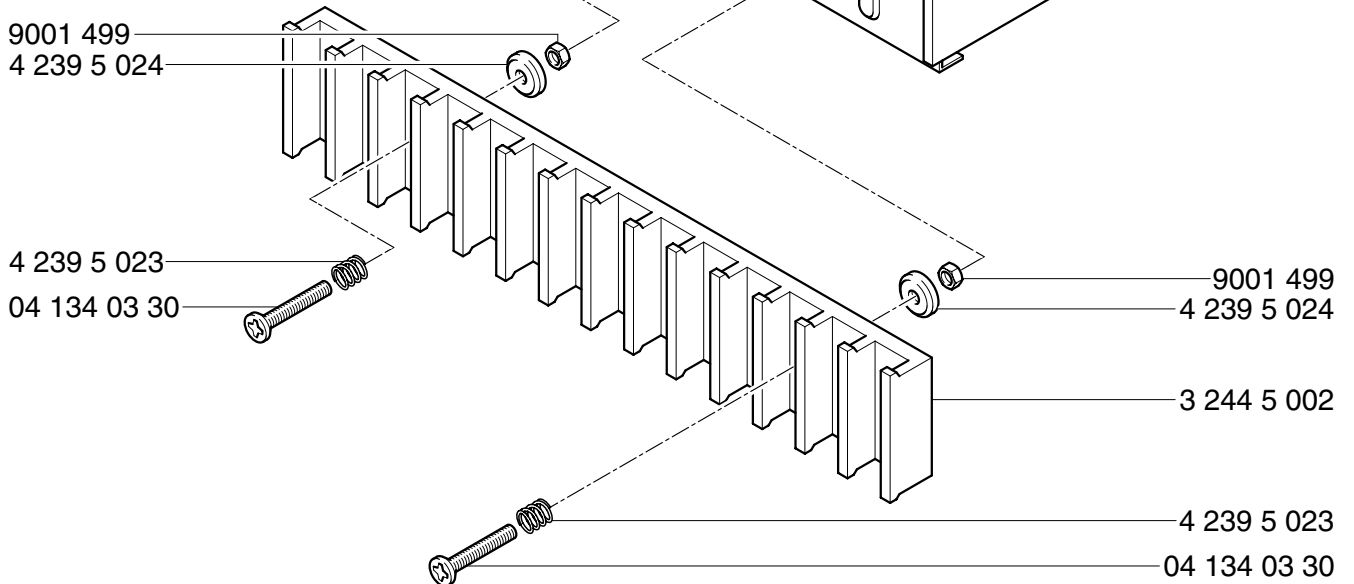
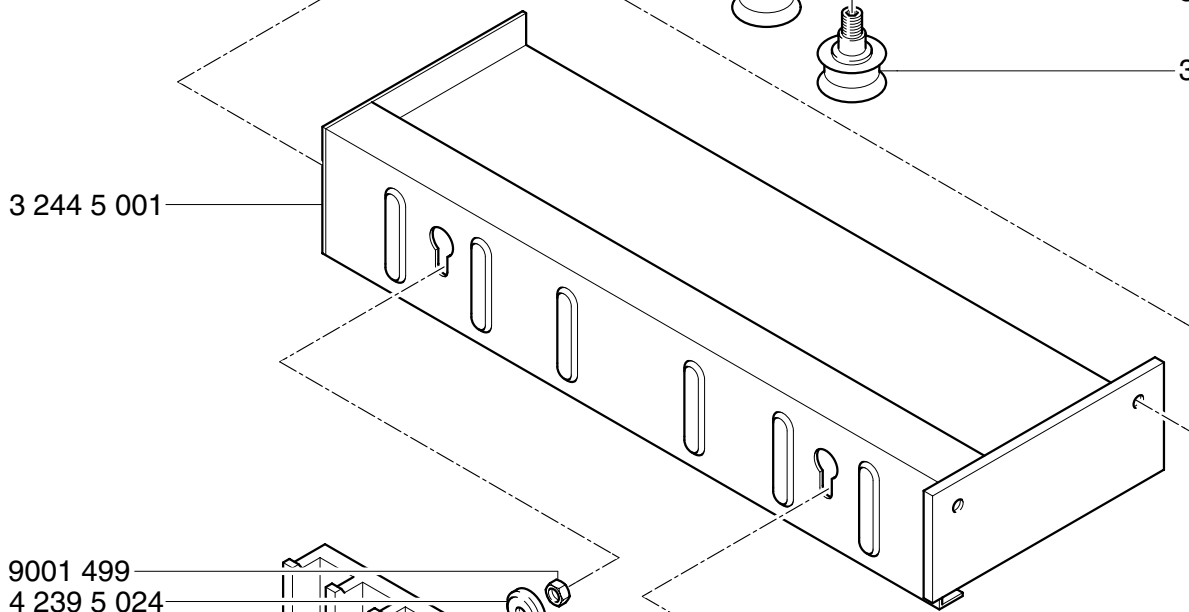
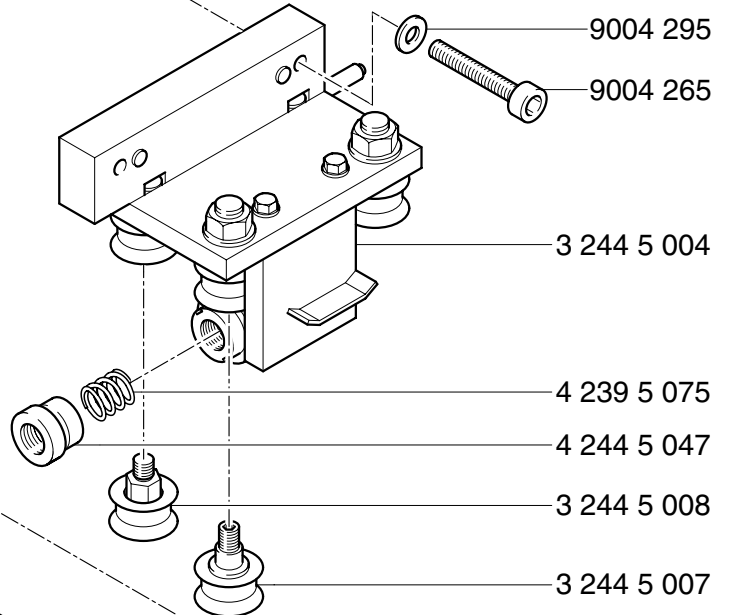
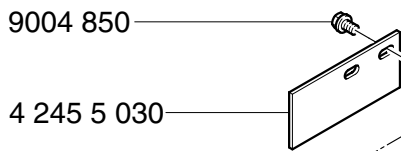
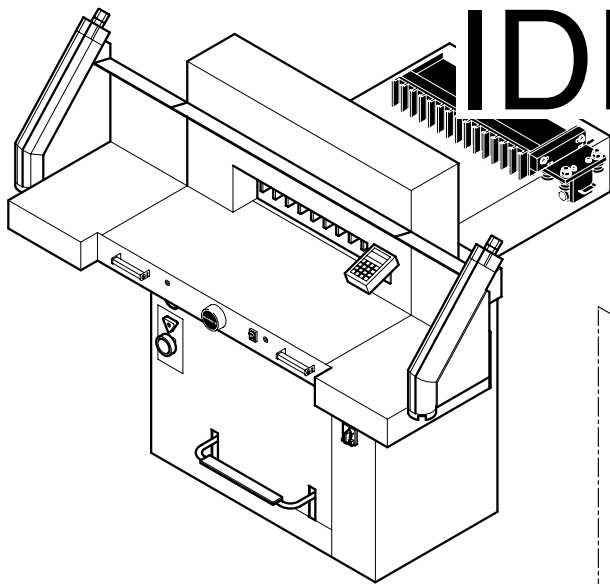

# IDEAL 5560 A

01.01.2014

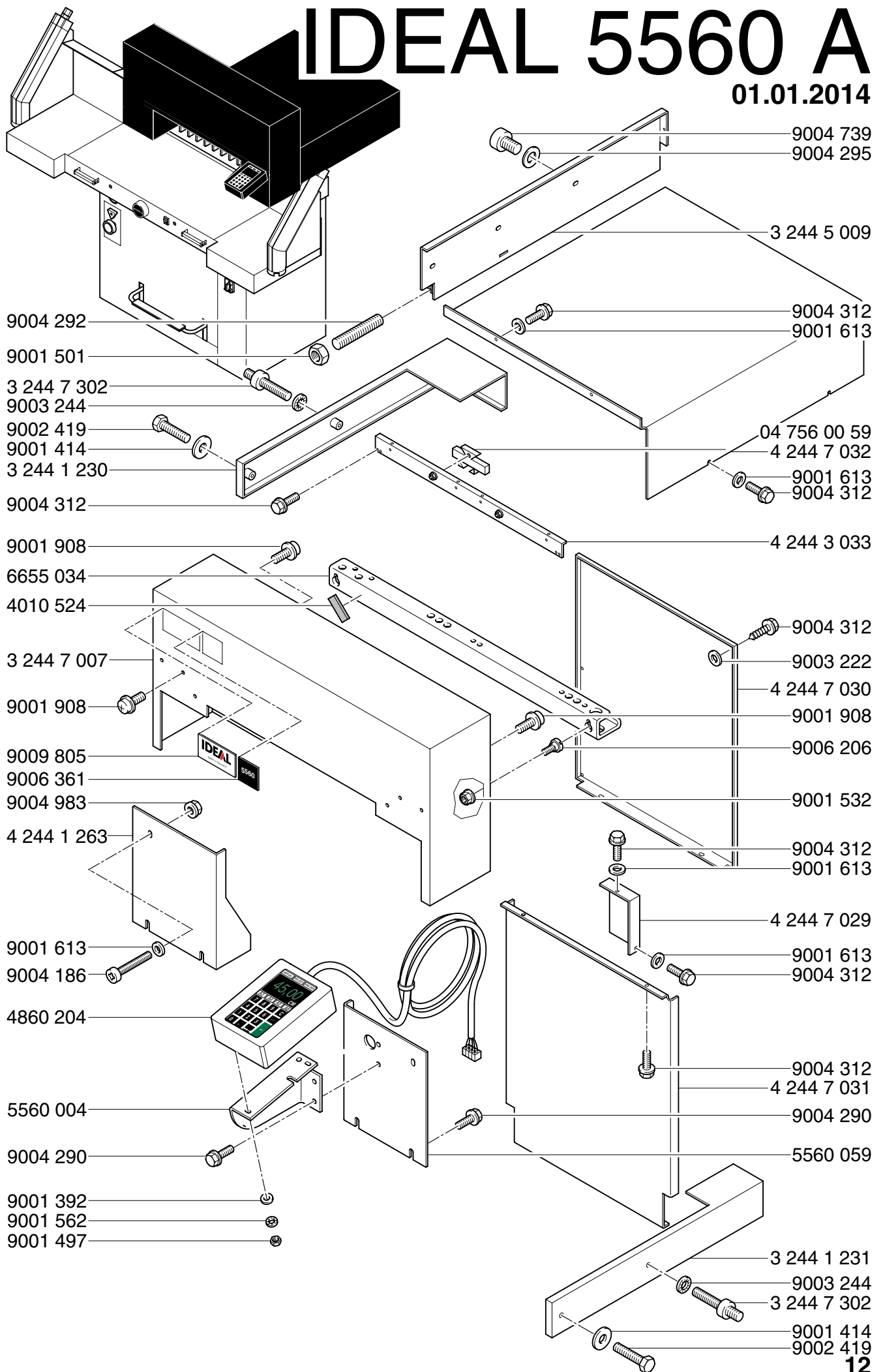

# IDEAL 5560 A

01.01.2014

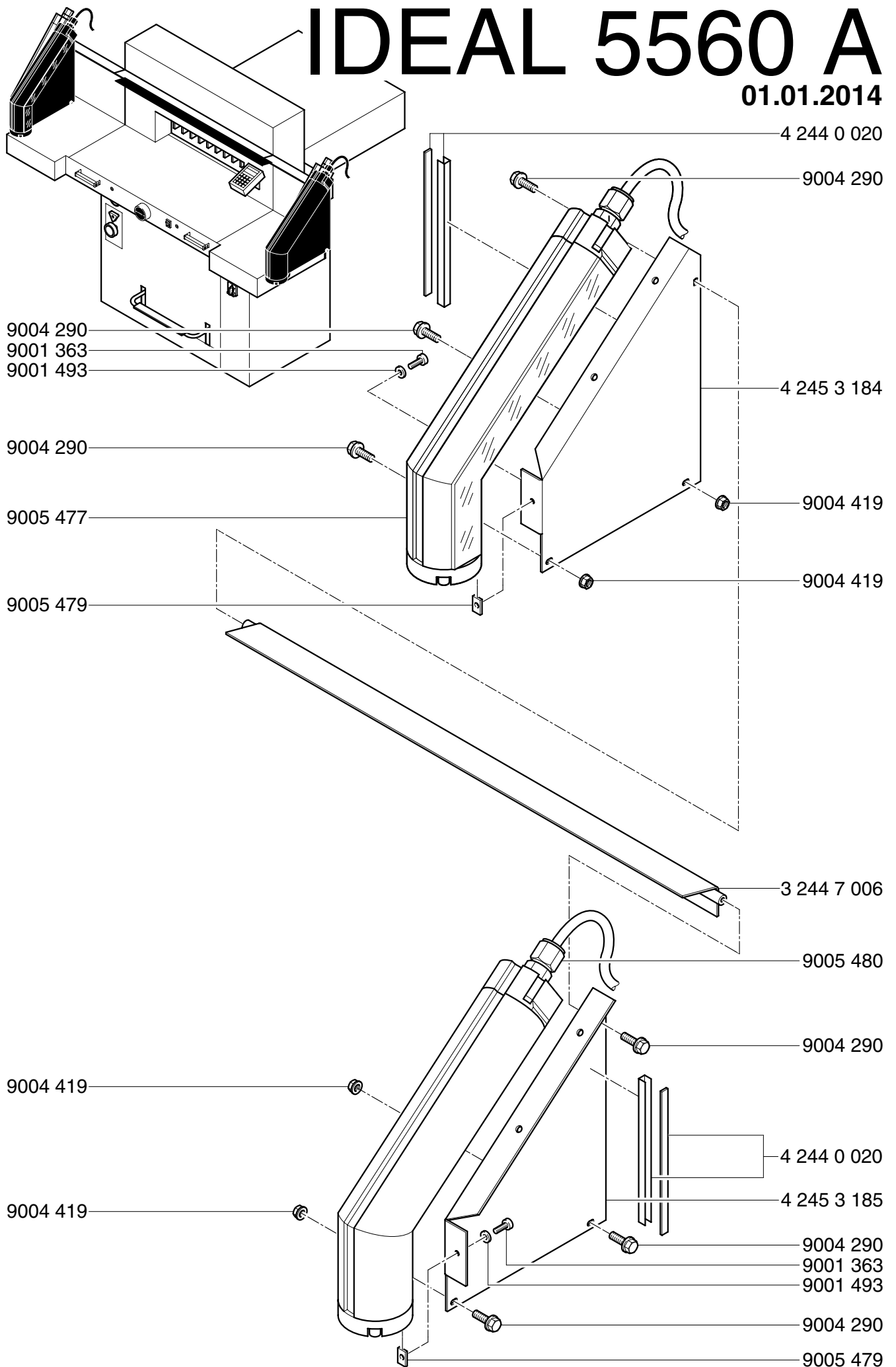

# IDEAL 5560 A

01.01.2014

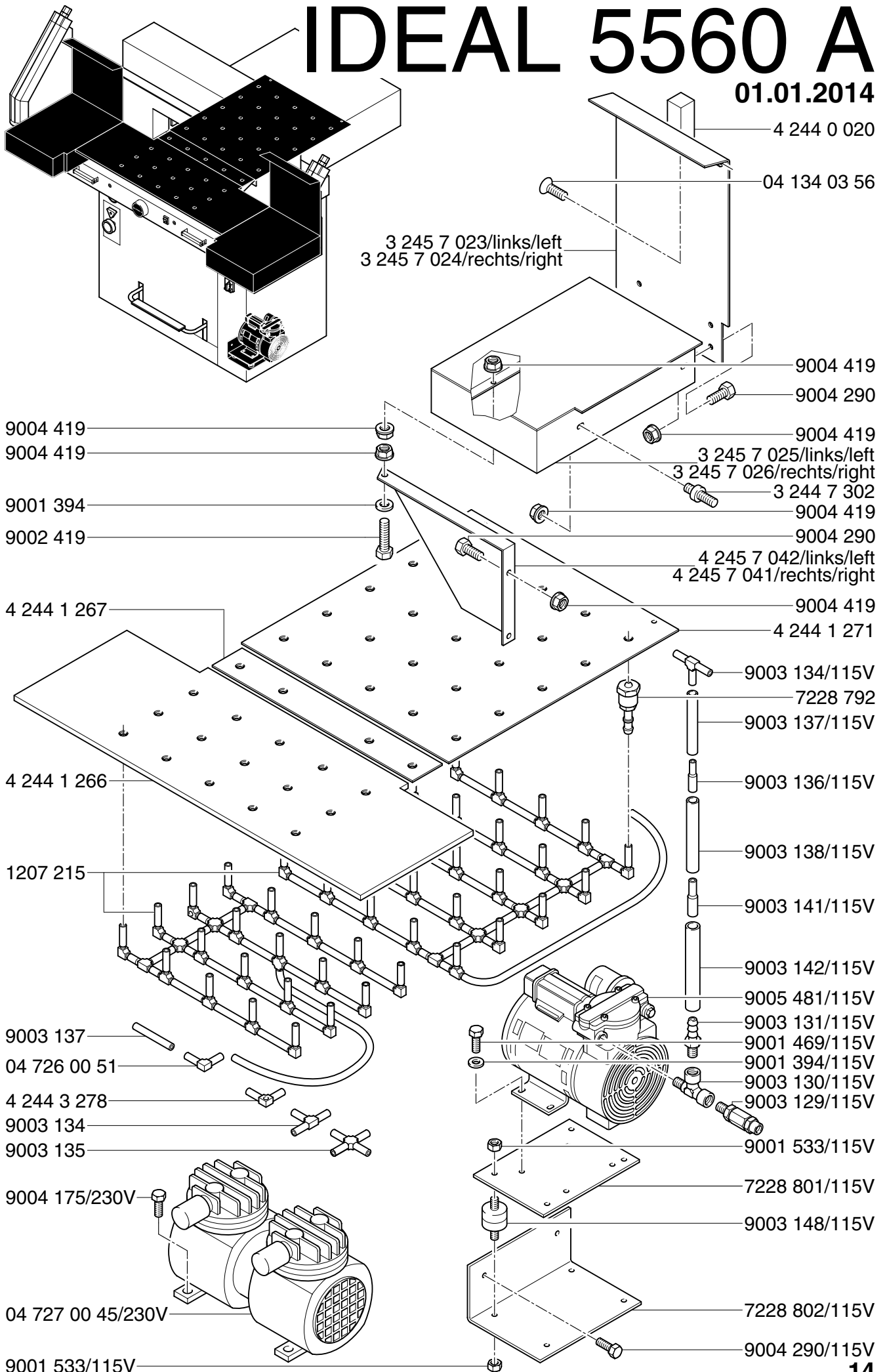

# IDEAL 5560 A

01.01.2014

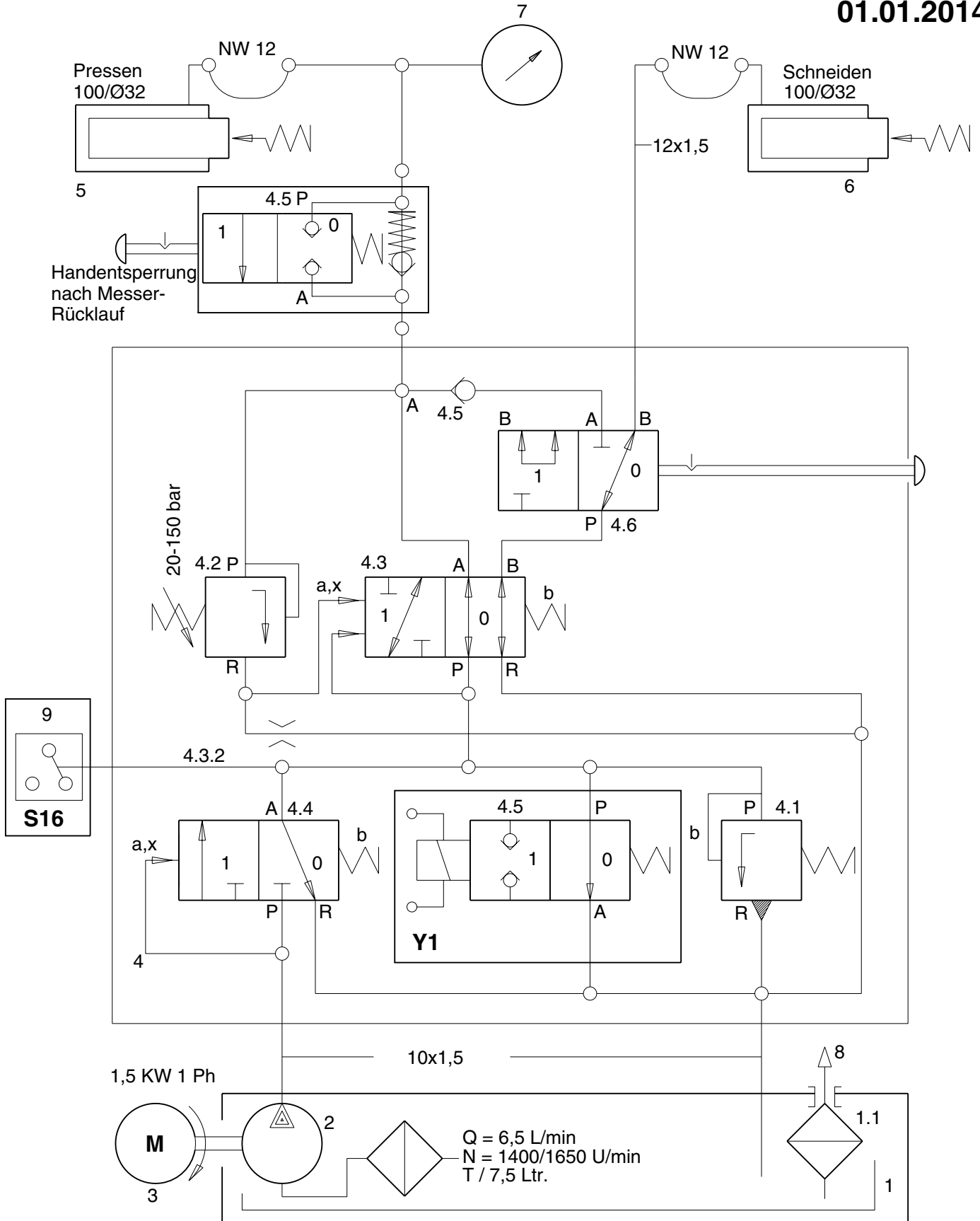

Max. Druck	160 bar
Ölempfehlung	Hydrauliköl DIN 52524T.7
Ölsorte	Aral Vitma DE 46
Fördermenge	6,4 L/min
Einfüllmenge	7,5 L
Filterfeinheit	100 um
E.-Motor, Drehzahl	1400 / 1650 U/min

4 245 3 258

# IDEAL 5560 A

01.01.2014

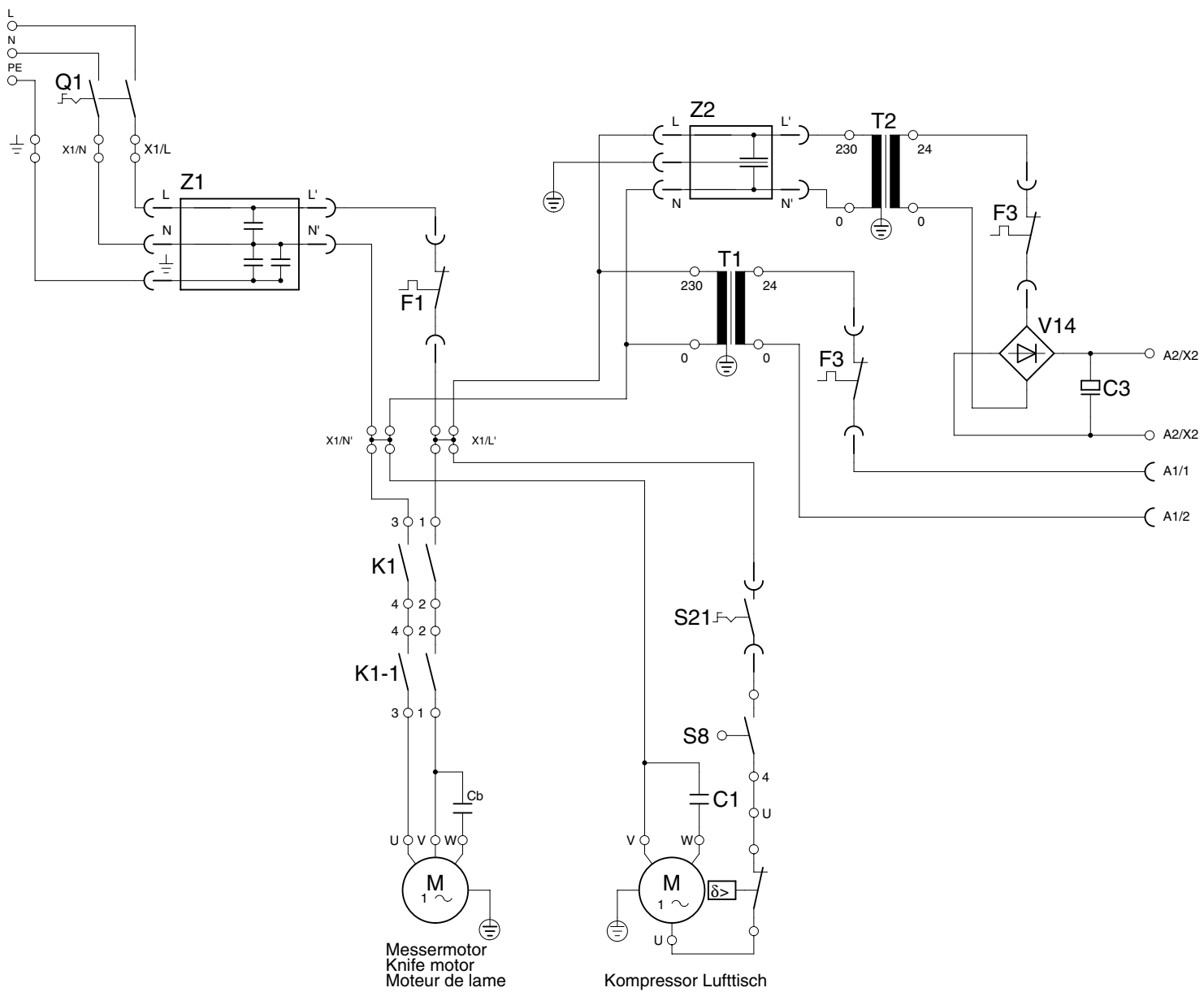



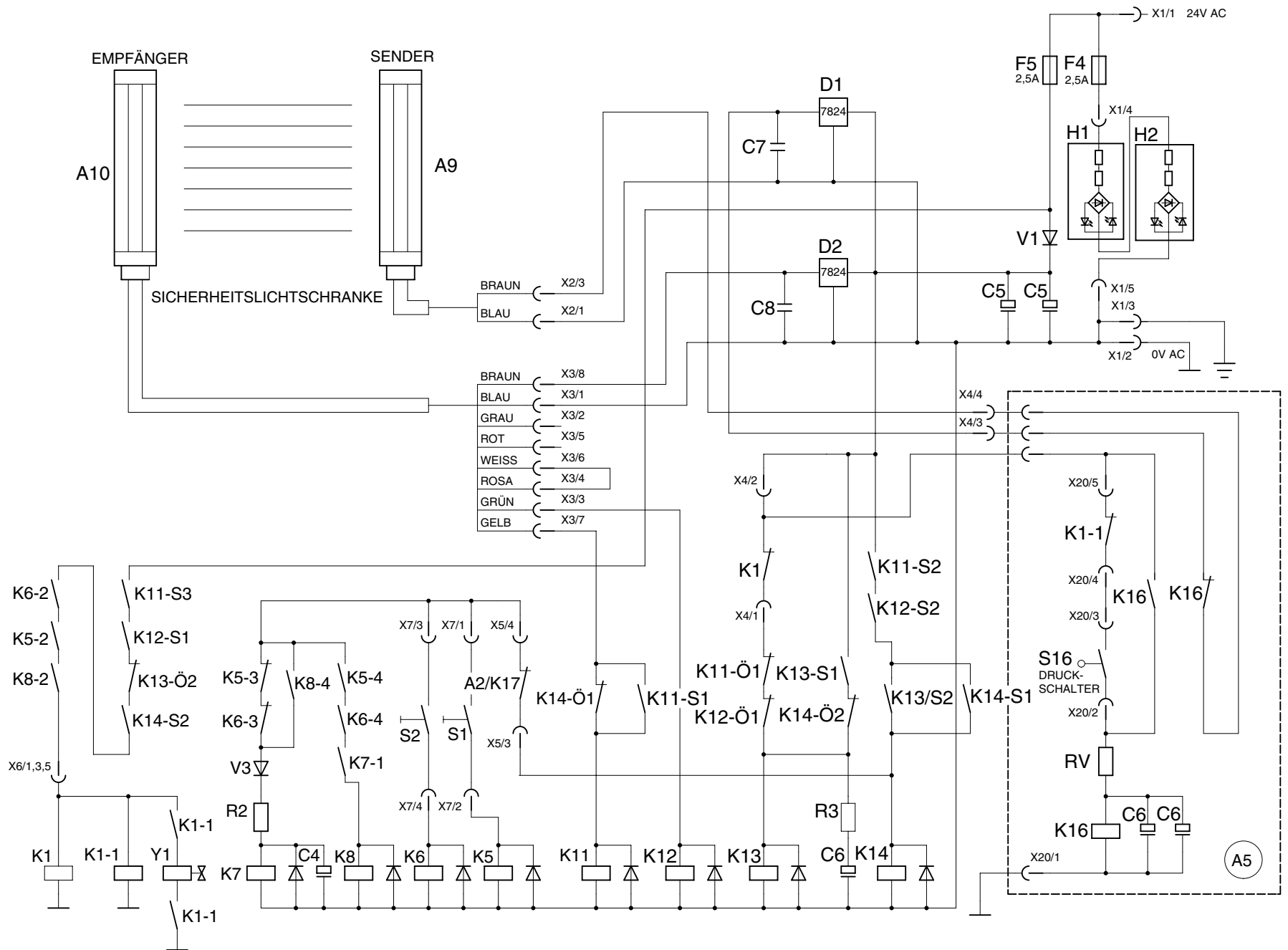

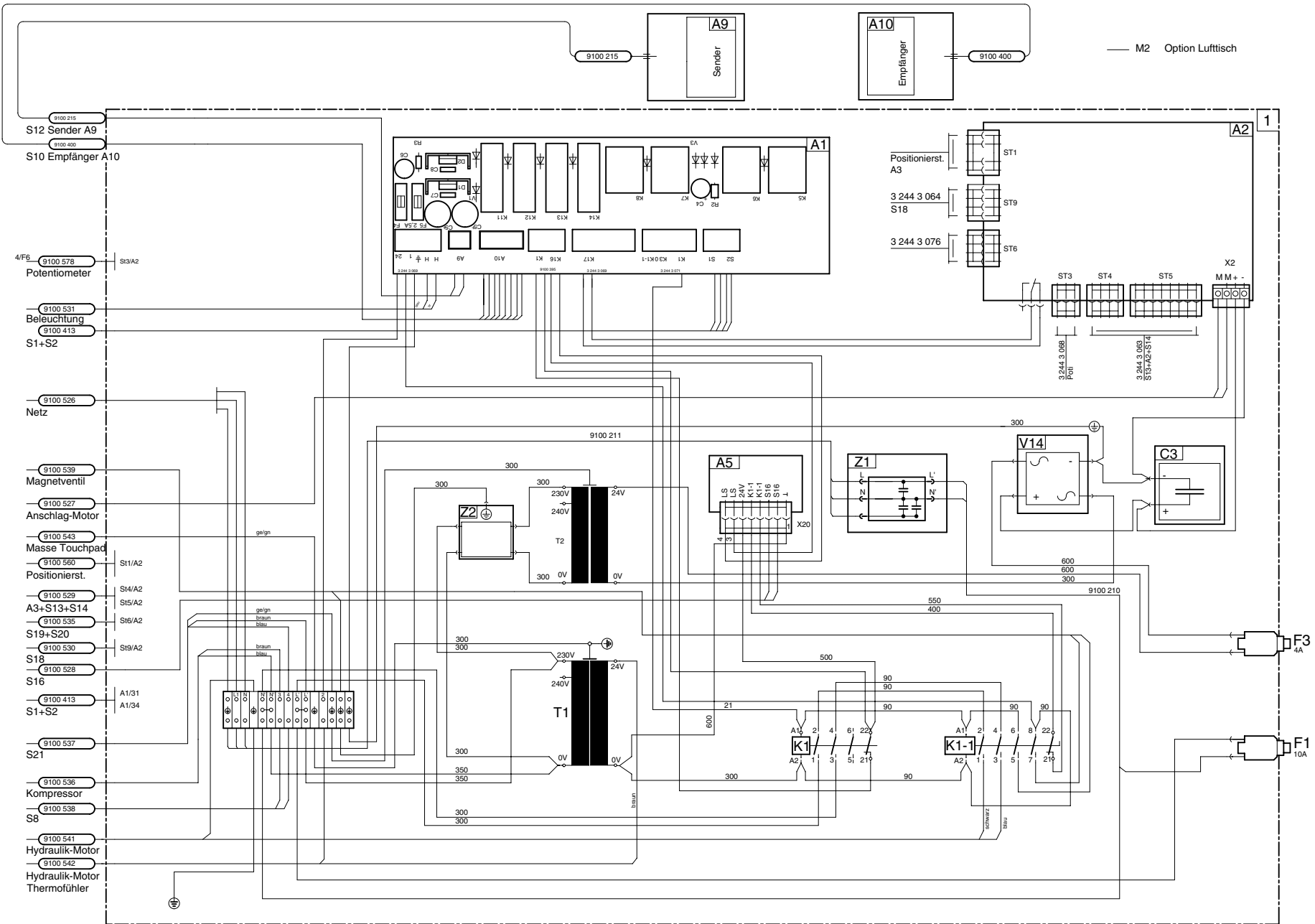

- 9100 215 S12 Sender A9
- 9100 400 S10 Empfänger A10
- 4/FB 9100 578 Potentiometer
- 9100 531 Beleuchtung
- 9100 413 S1+S2
- 9100 526 Netz
- 9100 539 Magnetventil
- 9100 527 Anschlag-Motor
- 9100 543 Masse Touchpad
- 9100 560 Positionierst.
- 9100 529 A3+S13+S14
- 9100 535 S19+S20
- 9100 530 S18
- 9100 528 S16
- 9100 413 S1+S2
- 9100 537 S21
- 9100 536 Kompressor
- 9100 538 S8
- 9100 541 Hydraulik-Motor
- 9100 542 Hydraulik-Motor Thermofühler

# IDEAL 5560 A

220-230V 01.01.2014

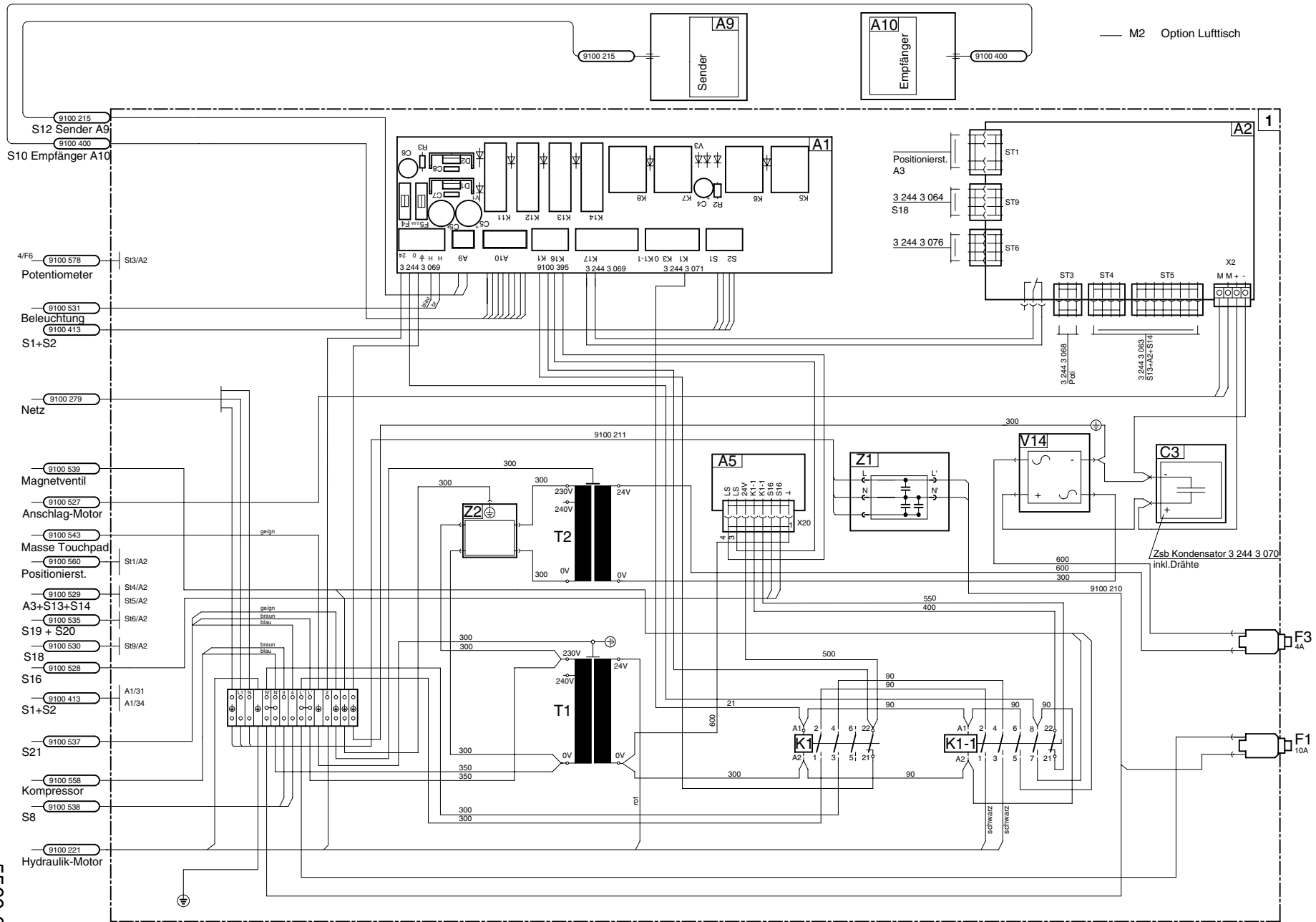

— M2 Option Lufttisch

# IDEAL 5560 A

120V 01.01.2014

# IDEAL 5560 A

01.01.2014

ST 1 = BUSKABEL ANZEIGEPLATINE  
 ST 3 = ANSCHLUSSKABEL HANDRAD  
 ST 4 = ANSCHLUSSKABEL DREHGEBER  
 ST 5 = ANSCHLUSSKABEL ENDSCHALTER  
 ST 6 = ANSCHLUSSKABEL MESSER OT/UT  
 ST 9 = ANSCHLUSSKABEL ABDECKBLECH (PRESSBALKEN)  
 M = ANSCHLUSS VORSCHUBMOTOR  
 +/- = ANSCHLUSS VERSORGNUNGSSPANNUNG  
 B/NC = KONTAKT SCHNEIDFREIGABE

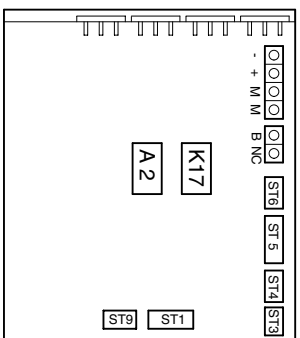
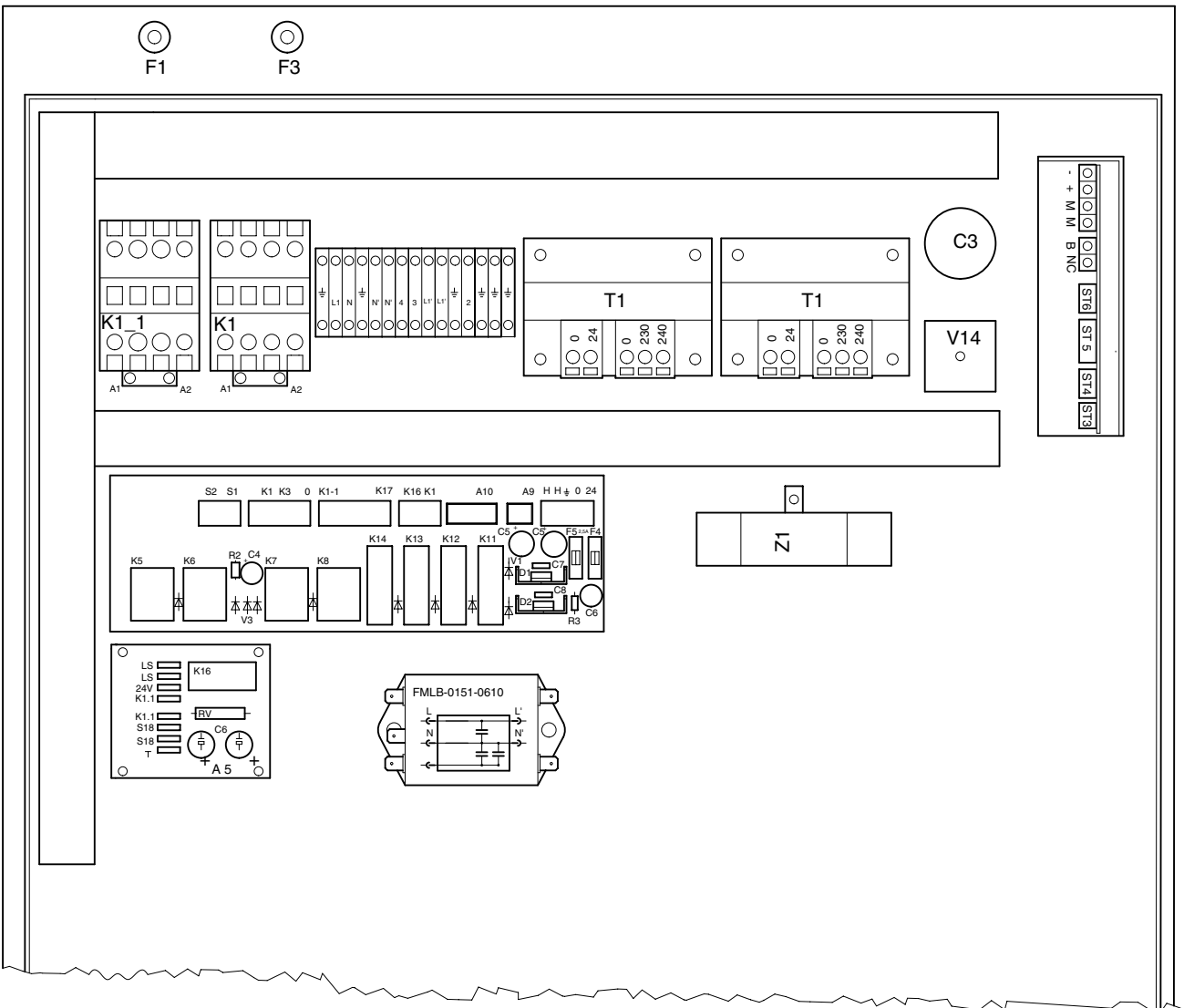

Code	Deutsch	English	Français	Nederlands	Italiano	Español
A1	Platine Steuerung	PCB control	Platine de commande	Stuurprintplaat	Scheda controllo	Placa de control
A4	Platine Rückanschlag	PCB backgauge	Platine butée arrière	Printplaat zadelmotor sturing	Scheda di battuta posteriore	Placa escuadra trasera
A5	Platine Geber	PCB encoder	Platine compteur d'impulsions	Printplaat encoder	Scheda contatore	Placa del encoder
A6	Platine Touchpad	PCB Touchpad	Platine Touchpad	Printplaat Touchpad	Scheda Touchpad	Placa Touchpad
A9	Platine Nachlauf	PCB overrun	Platine ralentissement	Printplaat vertraging	Scheda oltrecorsa	Placa deceleración
A10	Lichtschranke Sender	Photo cell transmitter	Cellule emettrice	Photocel zender	Fotocellula trasmittente	Transmisor célula fotoeléctrica
A11	Lichtschranke Empfänger	Photo cell receiver	Cellule receptrice	Photocel ontvanger	Fotocellula ricevente	Receptor célula fotoeléctrica
C1	Kondensator Motor	Capacitor motor	Condensateur moteur	Condensator motor	Condensatore motore	Condensador motor
C3	Kondensator Rückanschlag	Capacitor backgauge	Condensateur de butée arrière	Condensator achteraanleg	Condensatore battuta posteriore	Condensador escuadra trasera
C5	Kondensator Kompressor	Capacitor compressor	Condensateur compresseur	Condensator compressor	Condensatore compressore	Condensador compresor
F1	Überlastschutz Messermotor	Cutting motor overload protection	Disjoncteur moteur de lame	Thermische beveiliging snijmotor	Interruttore sovraccarico motore lama	Protector sobrecarga motor de corte
F3	Überlastschutz Rückanschlagmotor	Backgauge motor overload protection	Disjoncteur moteur de butée arrière	Thermische beveiliging motor achteraanleg	Interruttore sovraccarico motore battuta posteriore	Protector sobrecarga motor escuadra trasera
F4	Sicherung auf A1	Fuse on A1	Fusible sur A1	Zekering naar A1	Fusible su A1	Fusible a A1
F5	Sicherung auf A1	Fuse on A1	Fusible sur A1	Zekering naar A1	Fusible su A1	Fusible a A1
F6	Thermoschutz Hydraulik	Thermal protection hydraulics	Disjoncteur moteur hydraulique	Thermische beveiliging Hydrauliek	Interruttore sovraccarico idraulica	Protector sobrecarga hidráulica
F7	Thermoschutz Lufttisch	Thermal protection air table	Disjoncteur moteur table soufflante	Thermische beveiliging lucht tafel	Interruttore sovraccarico tavolo aria	Protector sobrecarga mesa de aire
H1	Schnittandeuter	Cutting line light	Ampoule ligne de coupe	Snijlijn-verlichting	Indicatore taglio	Luz de línea de corte
H2	Schnittandeuter	Cutting line light	Ampoule ligne de coupe	Snijlijn-verlichting	Indicatore taglio	Luz de línea de corte
K1	Schütz Messer ab	Knife-down contactor	Contacteur descente de lame	Relais-mes omlaag	Interruttore discesa lama	Contacto bajada cuchilla
K1/1	Schütz Messer ab	Knife-down contactor	Contacteur descente de lame	Relais-mes omlaag	Interruttore discesa lama	Contacto bajada cuchilla

Code	Deutsch	English	Français	Nederlands	Italiano	Español
K5	Relais Taster S1	Relay push button S1	Relais bouton poussoir S1	Relais-drukknop S1	Relè pulsante S1	Relé botón S1
K6	Relais Taster S2	Relay push button S2	Relais bouton poussoir S2	Relais-drukknop S2	Relè pulsante S2	Relé botón S2
K7	Relais Zeitverzögerung	Time-delay relay	Relais temporisé	Vertragsrelais	Relè de ritardo	Relé de atraso
K8	Relais Schnittwiederholung	Relay cutting repetition	Relais répétition de coupe	Relais-snijgangerhaling	Relè riperizione taglio	Relé repitição corte
K11	Sicherheitsrelais	Safety relay	Relais de sécurité	Veiligheidsrelais	Relè sicurezza	Relé de seguridad
K12	Sicherheitsrelais	Safety relay	Relais de sécurité	Veiligheidsrelais	Relè sicurezza	Relé de seguridad
K13	Sicherheitsrelais	Safety relay	Relais de sécurité	Veiligheidsrelais	Relè sicurezza	Relé de seguridad
K14	Sicherheitsrelais	Safety relay	Relais de sécurité	Veiligheidsrelais	Relè sicurezza	Relé de seguridad
K16	Relais Nachlaufüberwachung	Relay overrun control	Relais contrôle de ralentissement	Relais vertraging bewaking	Relè controllo oltrecorsa	Relé vigilancia de deceleración
K17	Relais Schnittsperre	Relay cut lock	Relais interdiction de coupe	Relais snij blokkering	Relè blocco di taglio	Relé bloqueo de corte
M1	Antriebsmotor Hydraulik	Hydraulic motor	Moteur pompe hydraulique	Motor hydrauliek	Motore trazione idraulica	Motor hidráulico
M3	Motor Rückanschlag	Backgauge motor	Moteur de butée arrière	Motor achter aanleg	Motore battuta posteriore	Motor de escuadra trasera
M4	Kompressor	Compressor	Compresseur	Compressor	Compressore	Compresor
Q1	Hauptschalter	Main switch	Interrupteur principal	Hoofdschakelaar	Interruttore principale	Interruptor principal
R9	Potentiometer Rückanschlag	Potentiometer backgauge	Potentiomètre butée arrière	Potentiometer aanleg achter	Potenzimetro battuta posteriore	Potenciómetro de escuadra trasera
S1	Taster Presse + Messer ab	Push button clamp + knife	Bouton poussoir commande presse + lame	Drukknop pers + mes	Pulsante pressino + lama	Botón prensa + cuchilla
S2	Taster Presse + Messer ab	Push button clamp + knife	Bouton poussoir commande presse + lame	Drukknop pers + mes	Pulsante pressino + lama	Botón prensa + cuchilla
S8	OT-Stopschalter Presse	Stop switch clamp top	Fin de course arrêt presse haut	Schakelaar pers boven	Fermo pressino alto	Detención prensa arriba
S13	Endschalter Rückanschlag vorne	Limit switch backgauge forward	Fin de course avant butée arrière de sécurité	Eindschakelaar aanleg voor	Interruttore limite di avanzamento squadra	Interruptor marca frontal
S14	Endschalter Rückanschlag hinten	Limit switch backgauge backward	Fin de course avant butée arrière	Eindschakelaar aanleg achter	Interruttore limite di ritorno squadra	Interruptor marca trasera

Code	Deutsch	English	Français	Nederlands	Italiano	Español
S16	Schalter Öldruck Überwachung	Switch oil pressure control	Interrupteur contrôle de pression d'huile	Schakelaar overdrukventiel	Interruttore controllo	Interruptor vigilancia del oleografía
S17	Schalter Pressbalkenabdeckung	Switch false clamp plate	Interrupteur présence plaque de presse	Persebalk afdekplaat achakelaar	Pressione dell'olio	Interruptor protección falso pisón
S19	UT-Stopschalter Messer	Stop switch knife bottom	Fin de course arrêt lame bas	Schakelaar mes beneden	Fermo lama basso	Detención cuchilla abajo
S20	OT-Stopschalter Presse	Stop switch clamp top	Fin de course arrêt presse haut	Schakelaar pers boven	Fermo pressino alto	Detención prensa arriba
S21	Schalter Lufttisch	Switch air table	Interrupteur table soufflante	Loket lucht tafel	Interruttore tavolo aria	Interruptor mesa de aire
T1	Transformator	Transformer	Transformateur	Transformator	Trafoformatore	Transformador
T2	Transformator	Transformer	Transformateur	Transformator	Trafoformatore	Transformador
V14	Gleichrichter Rückanschlag	Rectifier backgauge	Redresseur butée arrière	Gelijkrichter- achteraanleg	Raddrizzatore battuta posteriore	Rectificador escuadra trasera
Y1	Hydraulik Ventil	Hydraulic valve	Electrovanne hydraulique	Hydrauliek Ventiel	Valvola idraulica	Válvula hidráulica
Z1	Netzfilter	Filter	Filtre	Netfilter	Filtro	Filtro
Z2	Netzfilter	Filter	Filtre	Netfilter	Filtro	Filtro

# IDEAL 5560 A

01.01.2014

