

Mod. 5009-3
 CROSS / CUT
 01.11.2010

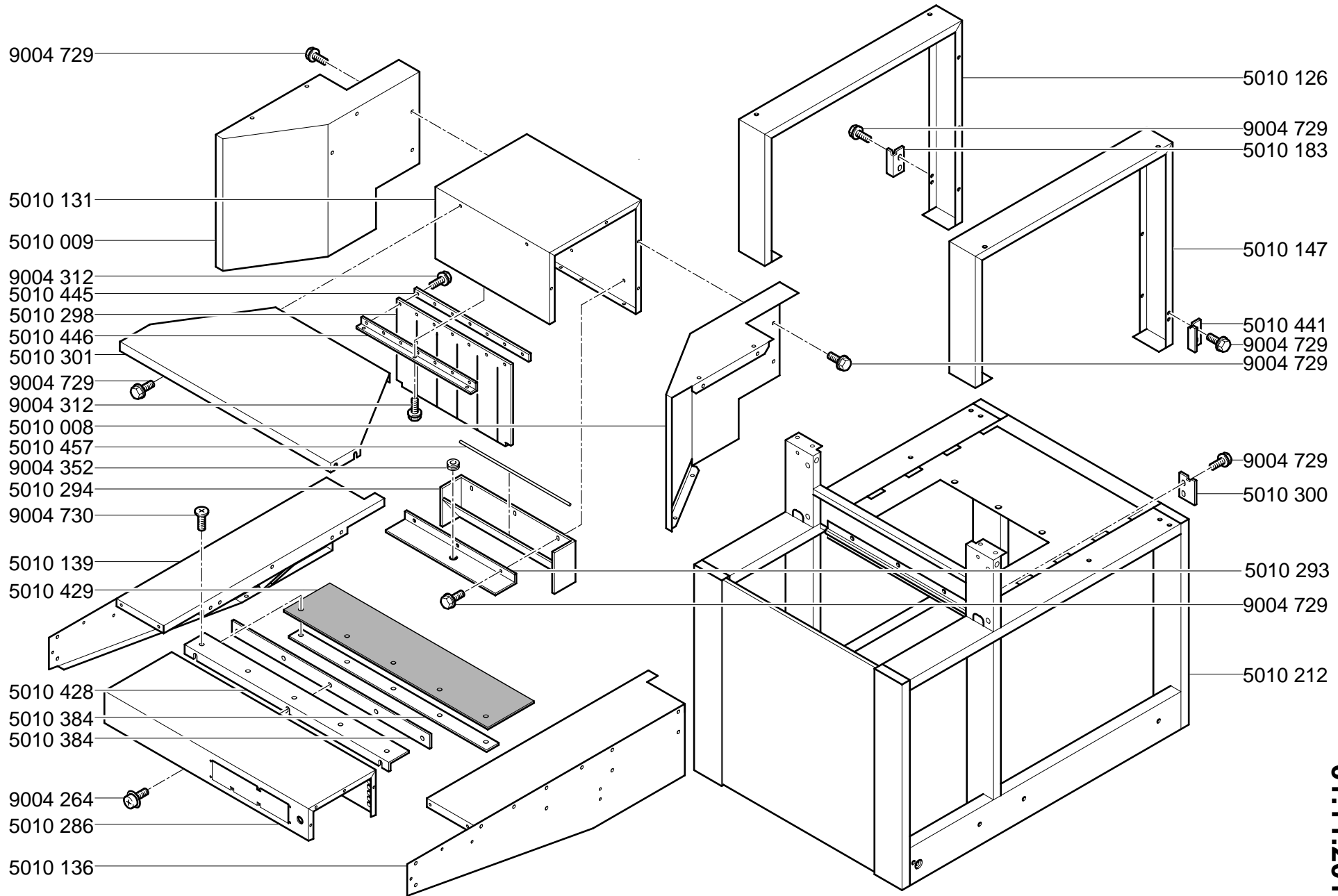

Mod. 5009-3
 CROSS / CUT
 01.11.2010

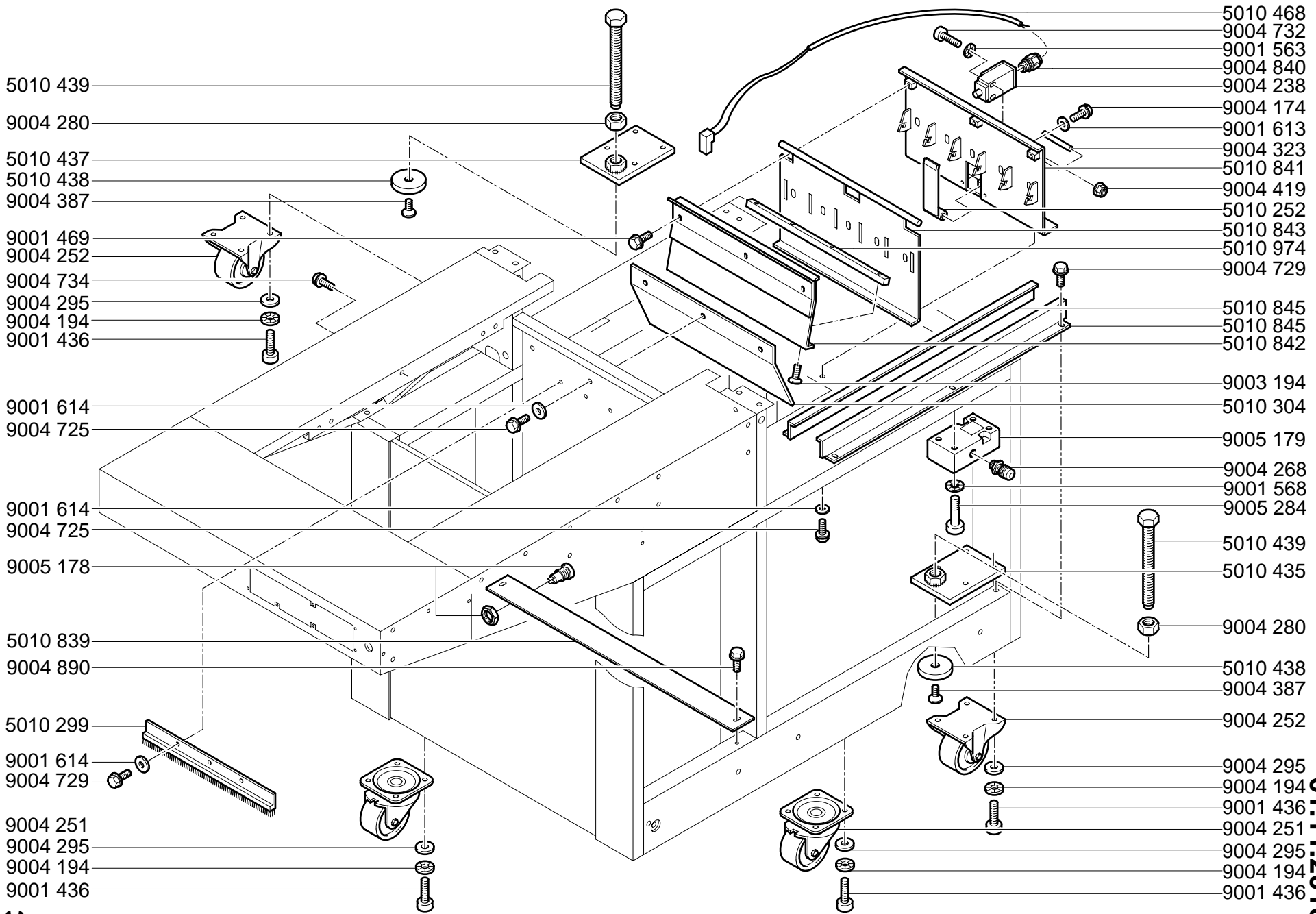

Mod. 5009-3
 CROSS / CUT
 01.11.2010

CROSS / CUT Mod.5009-3

01.11.2010

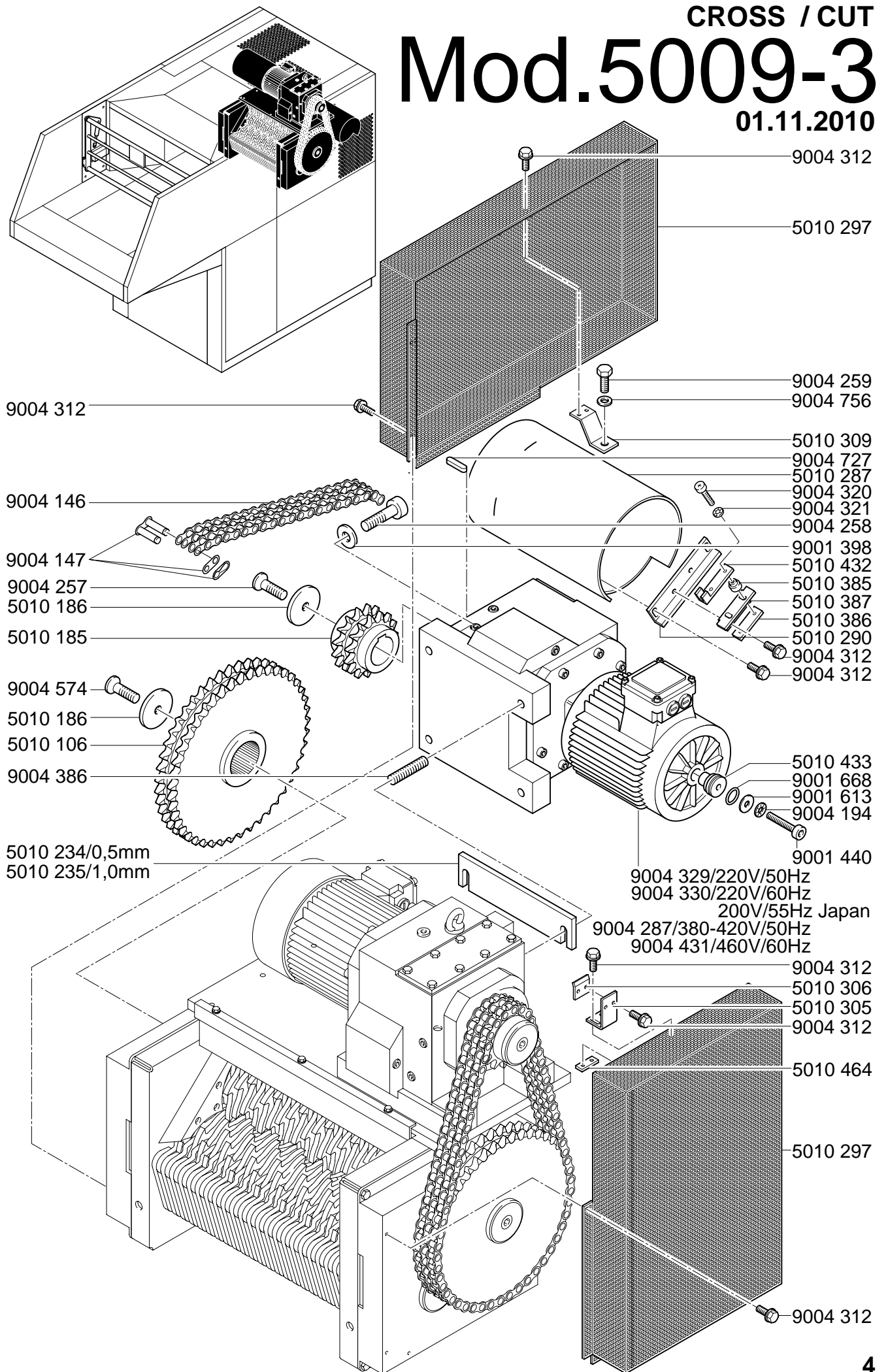

CROSS / CUT
Mod.5009-3
 01.11.2010

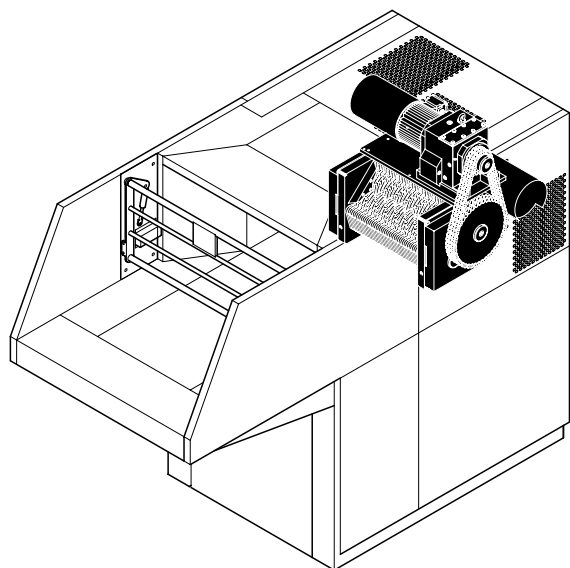

9004 258
 9001 398

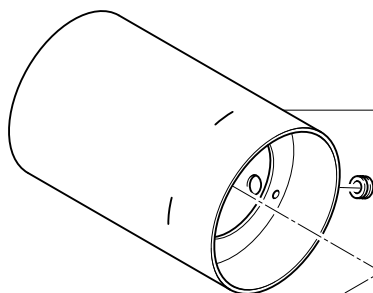

5010 287

9002 194

9004 727

9004 329/220V/50Hz
 9004 330/220V/60Hz
 200V/55Hz Japan
 9004 287/380-420V/50Hz
 9004 431/460V/60Hz

5010 234/0,5mm
 5010 235/1,0mm

9004 170
 5010 321

5010 178
 9001 503
 9001 331

5010 687

9001 819
 9004 367
 9004 331
 9004 259

9001 502
 9004 288

5010 444

9001 502
 9004 288

9004 146

5010 185

5010 186

9004 257

9004 147

5010 106

5010 186

9004 574

9001 819

9004 259

9001 503

9005 092

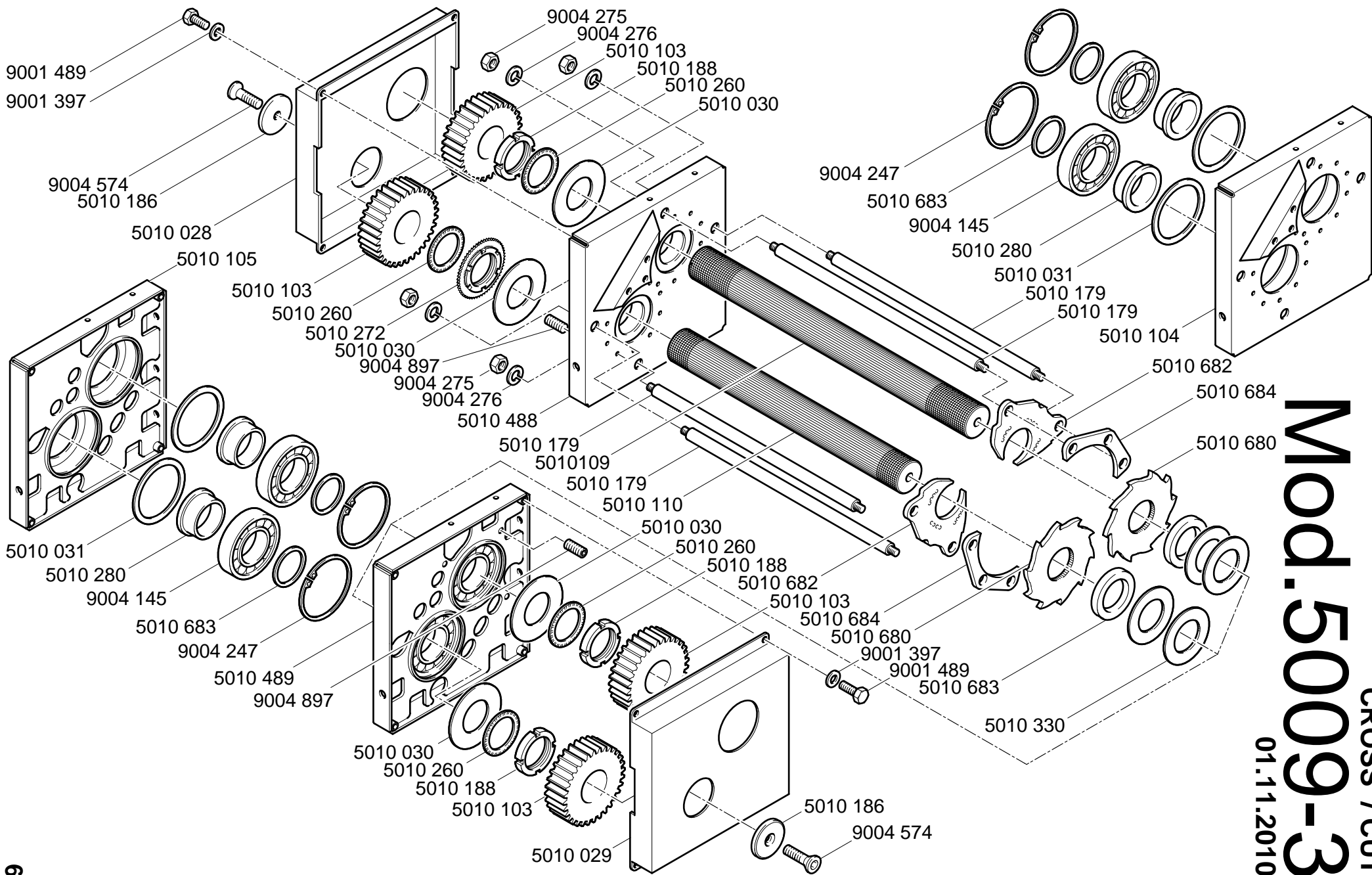

Mod. 5009-3
 CROSS / CUT
 01.11.2010

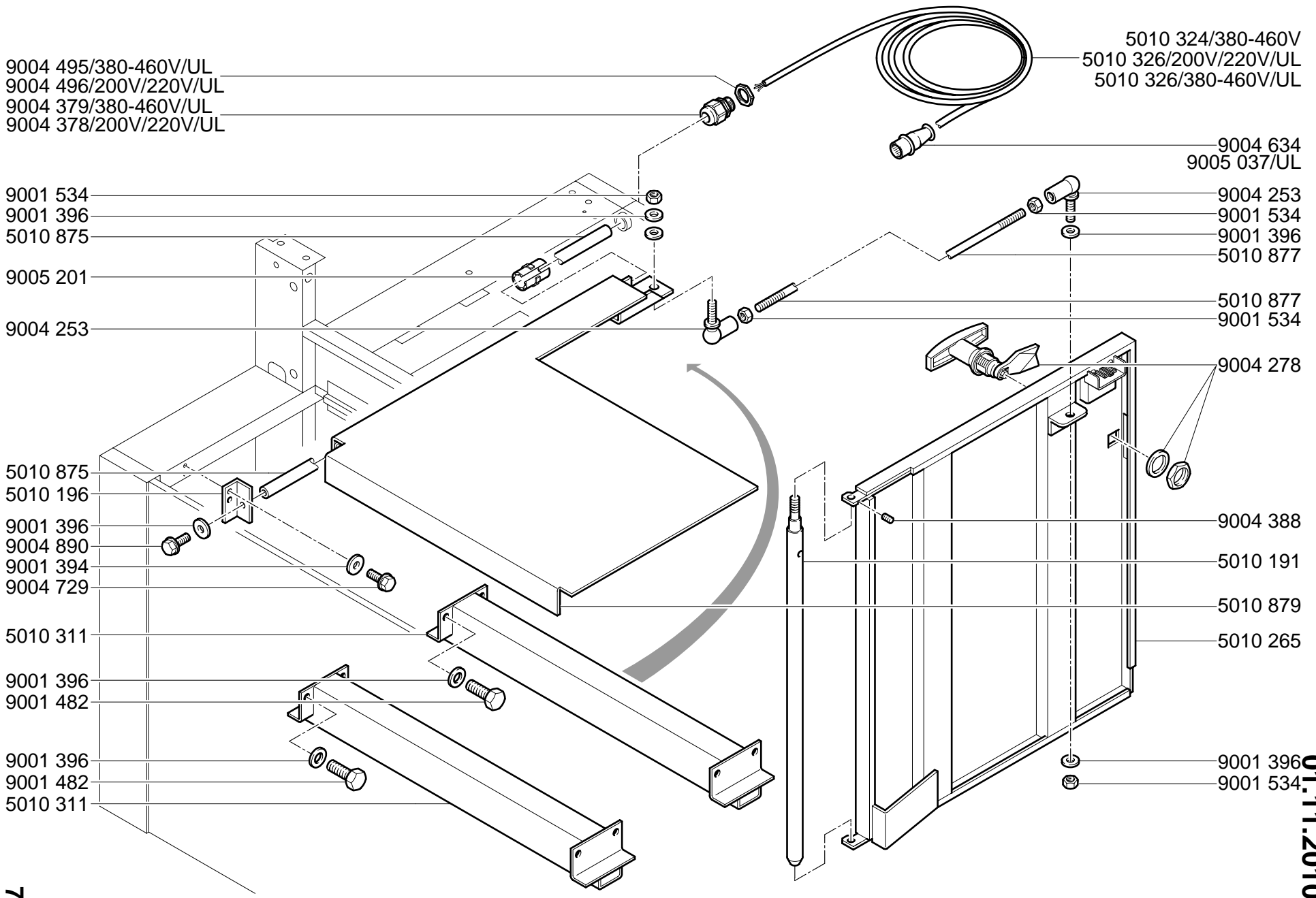

CROSS / CUT
Mod. 5009-3
 01.11.2010

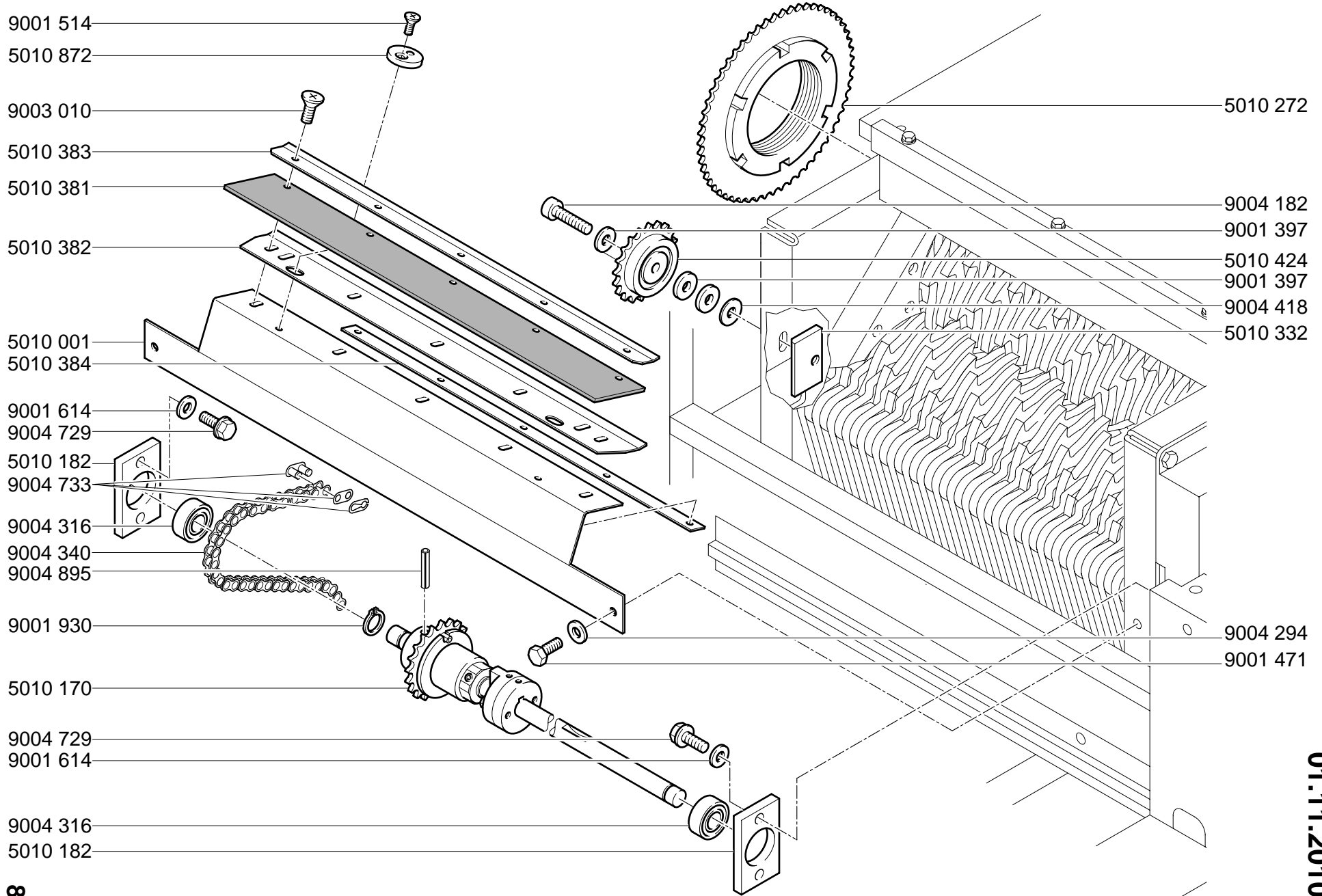

CROSS / CUT
Mod. 5009-3
 01.11.2010

CROSS / CUT
Mod.5009-3
 01.11.2010

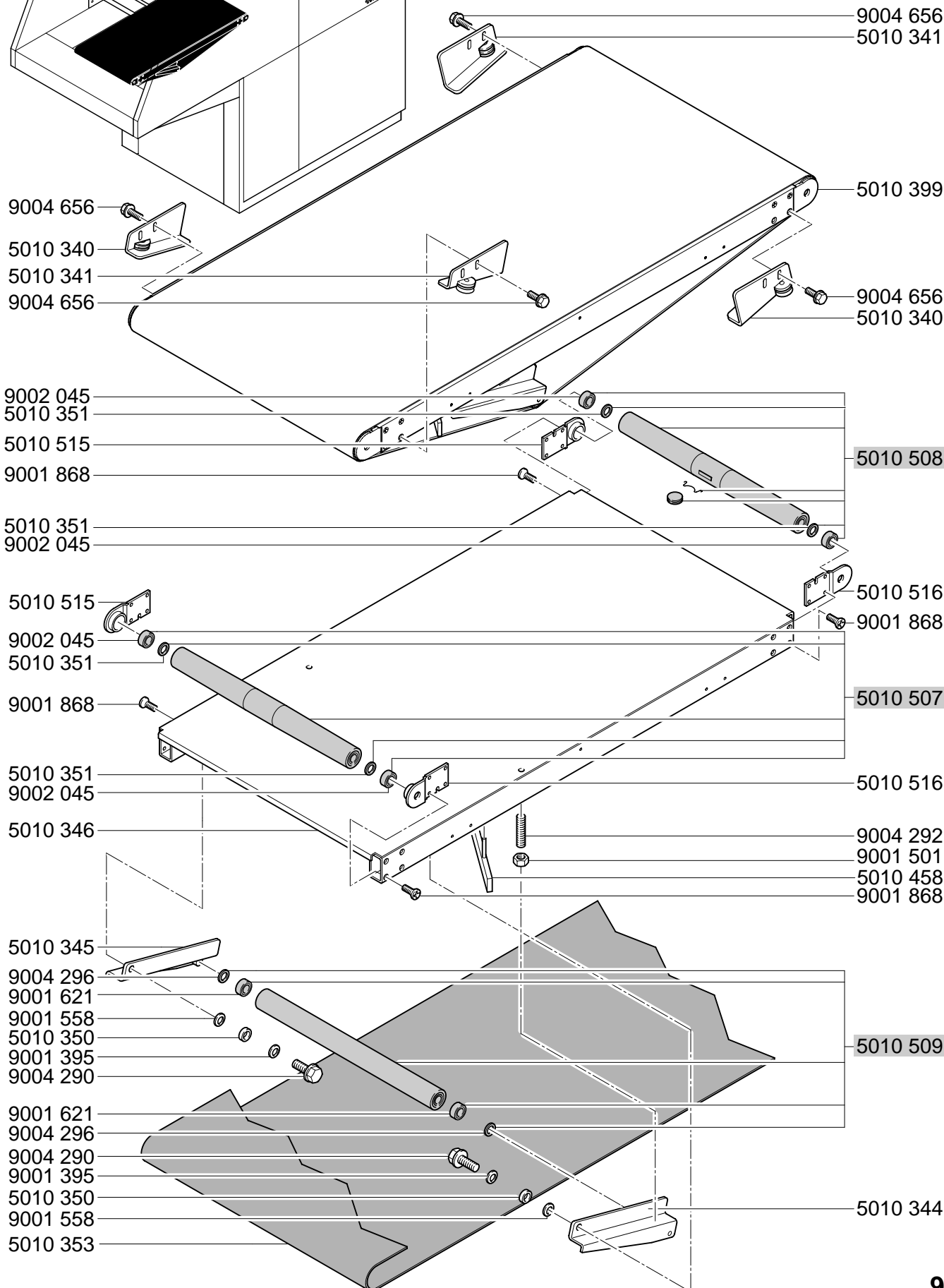
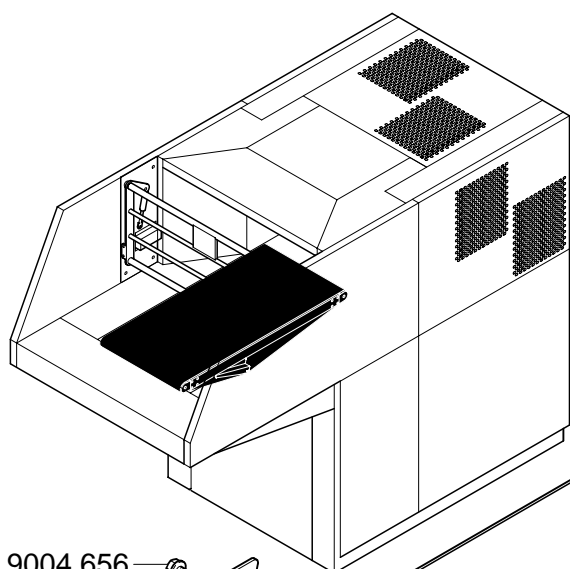

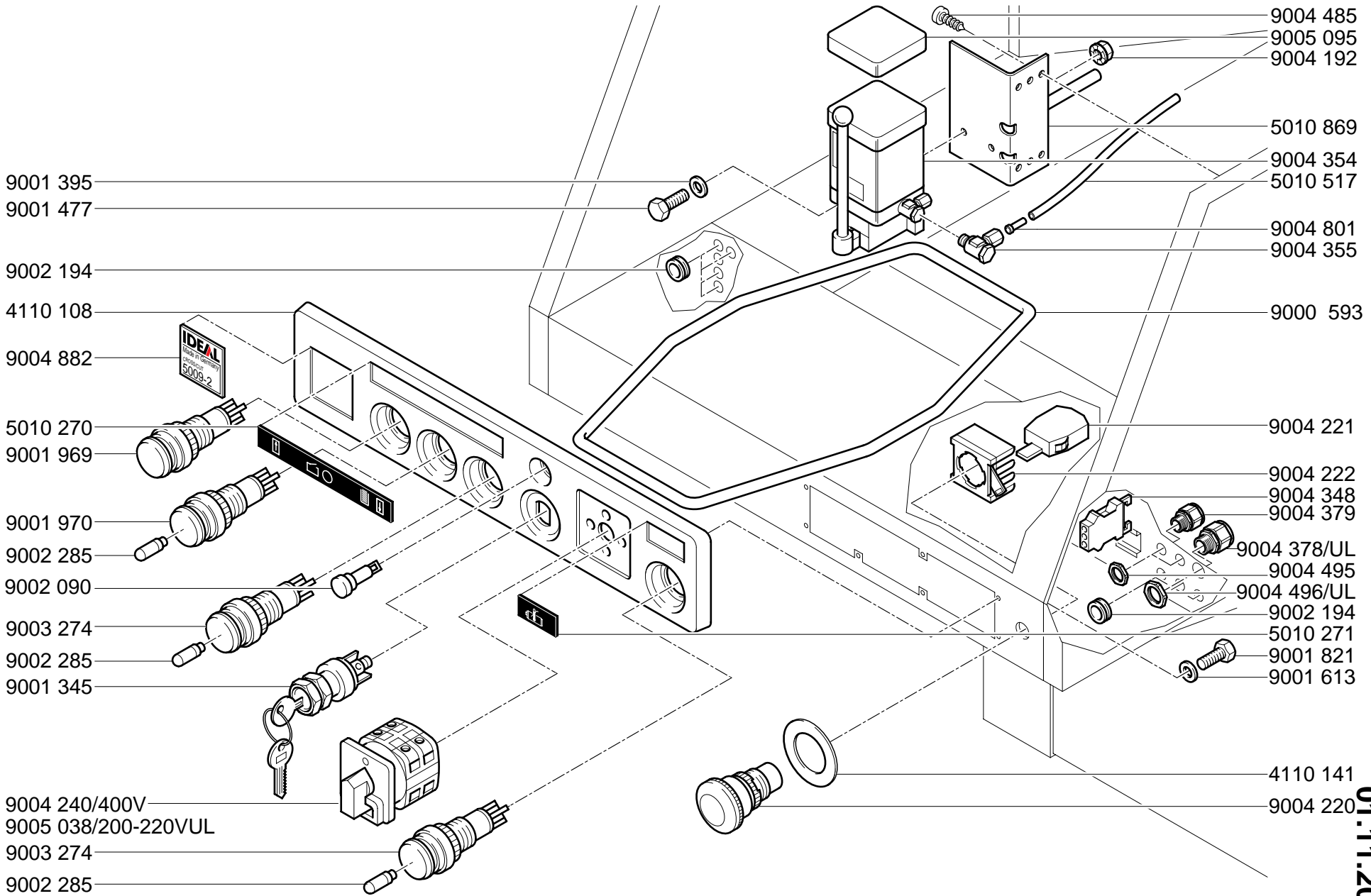

CROSS / CUT
Mod. 5009-3
 01.11.2010

CROSS / CUT
Mod.5009-3
01.11.2010

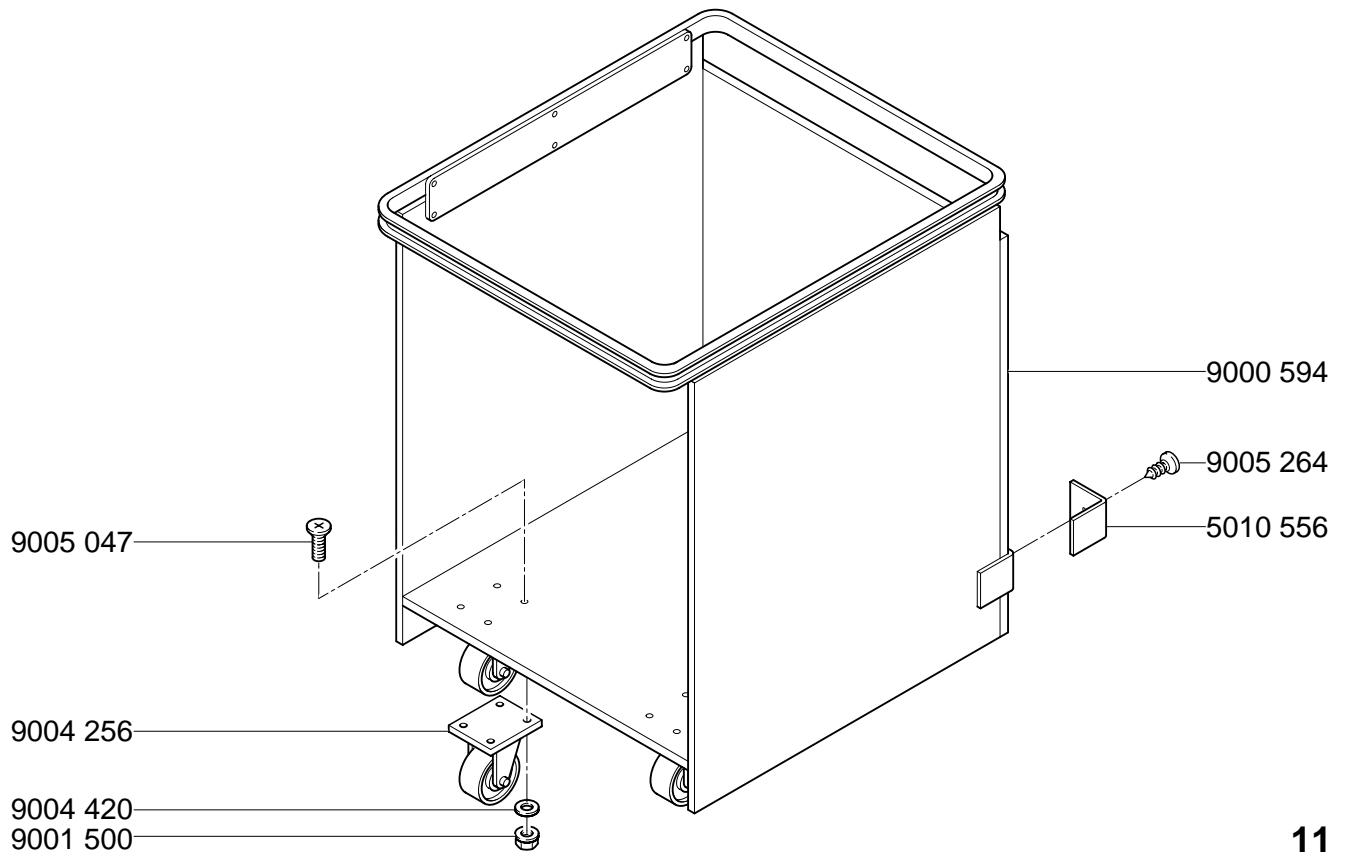
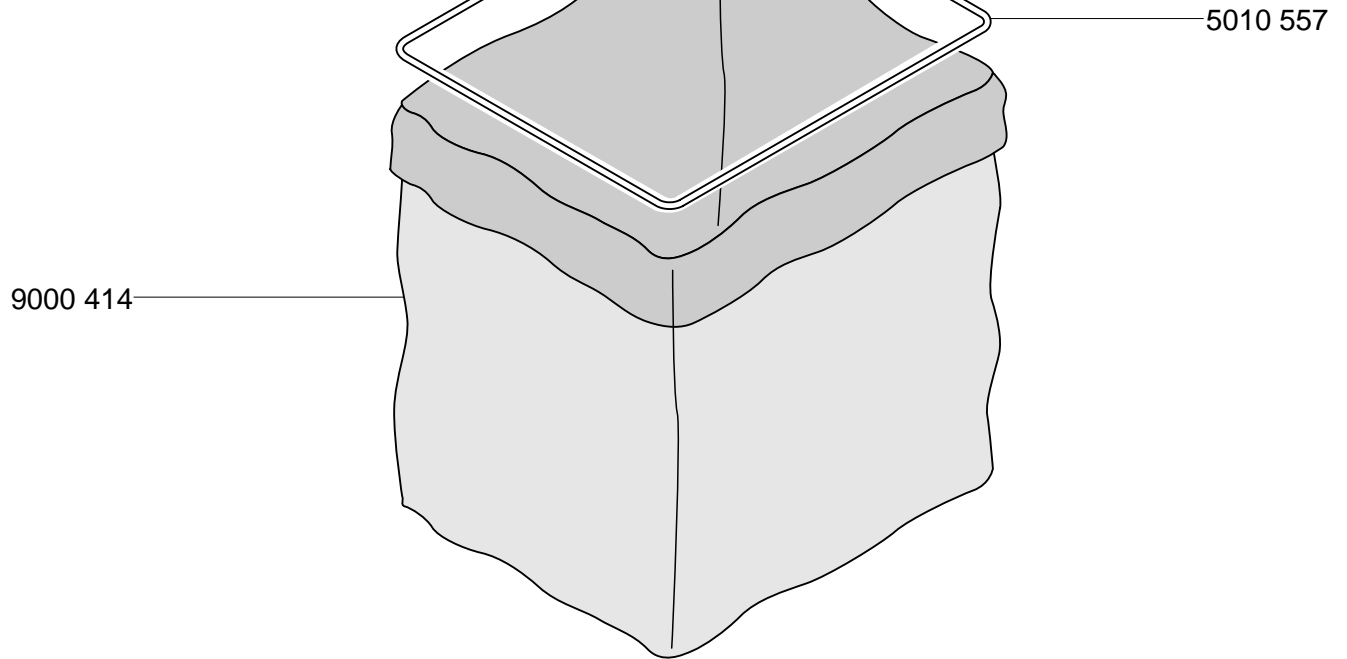
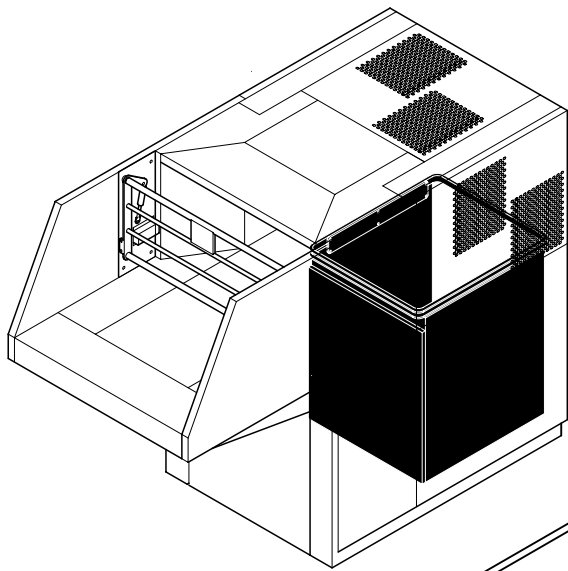

Mod.5009-3

01.11.2010

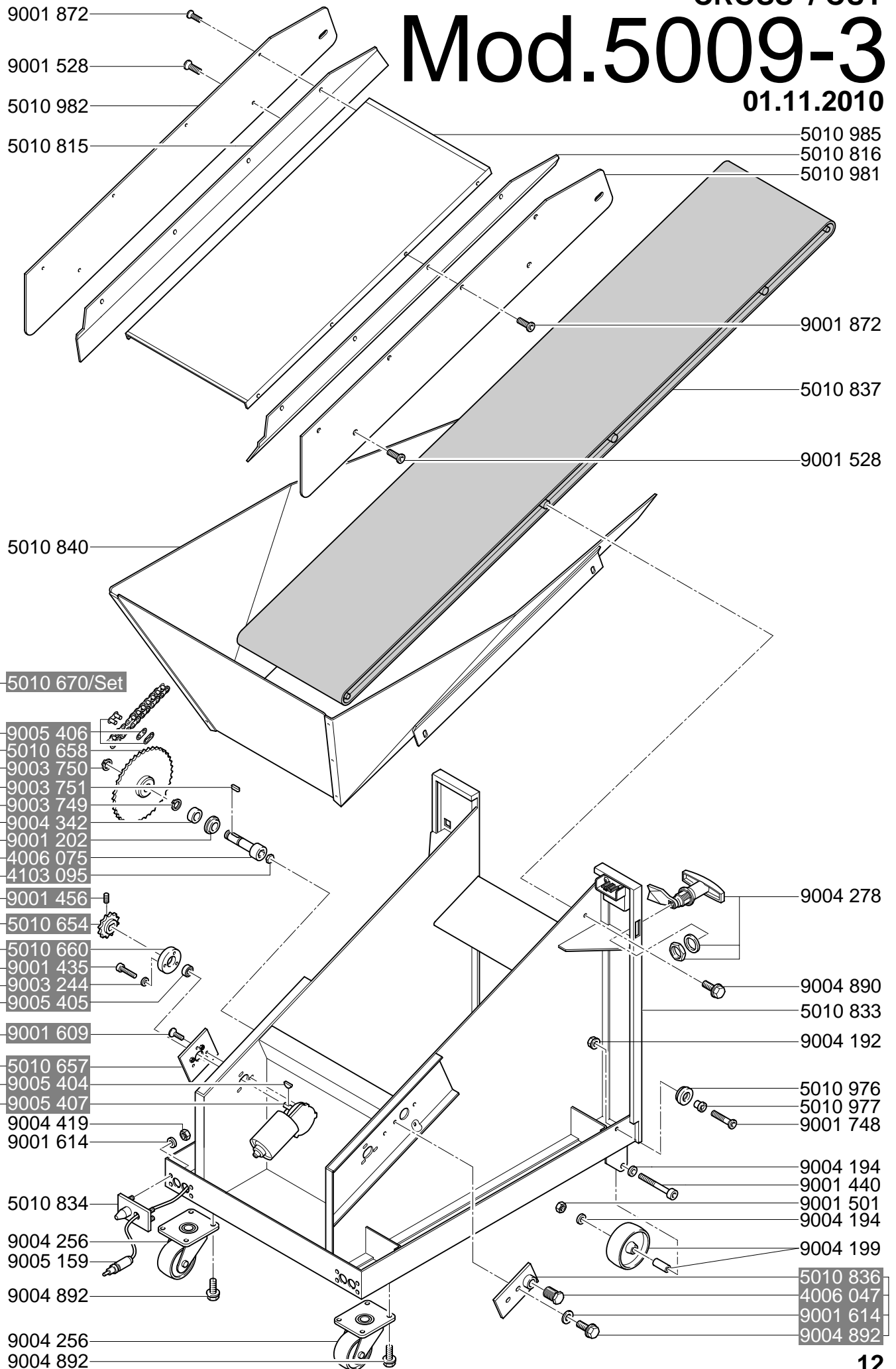

CROSS / CUT
Mod.5009-3

01.11.2010

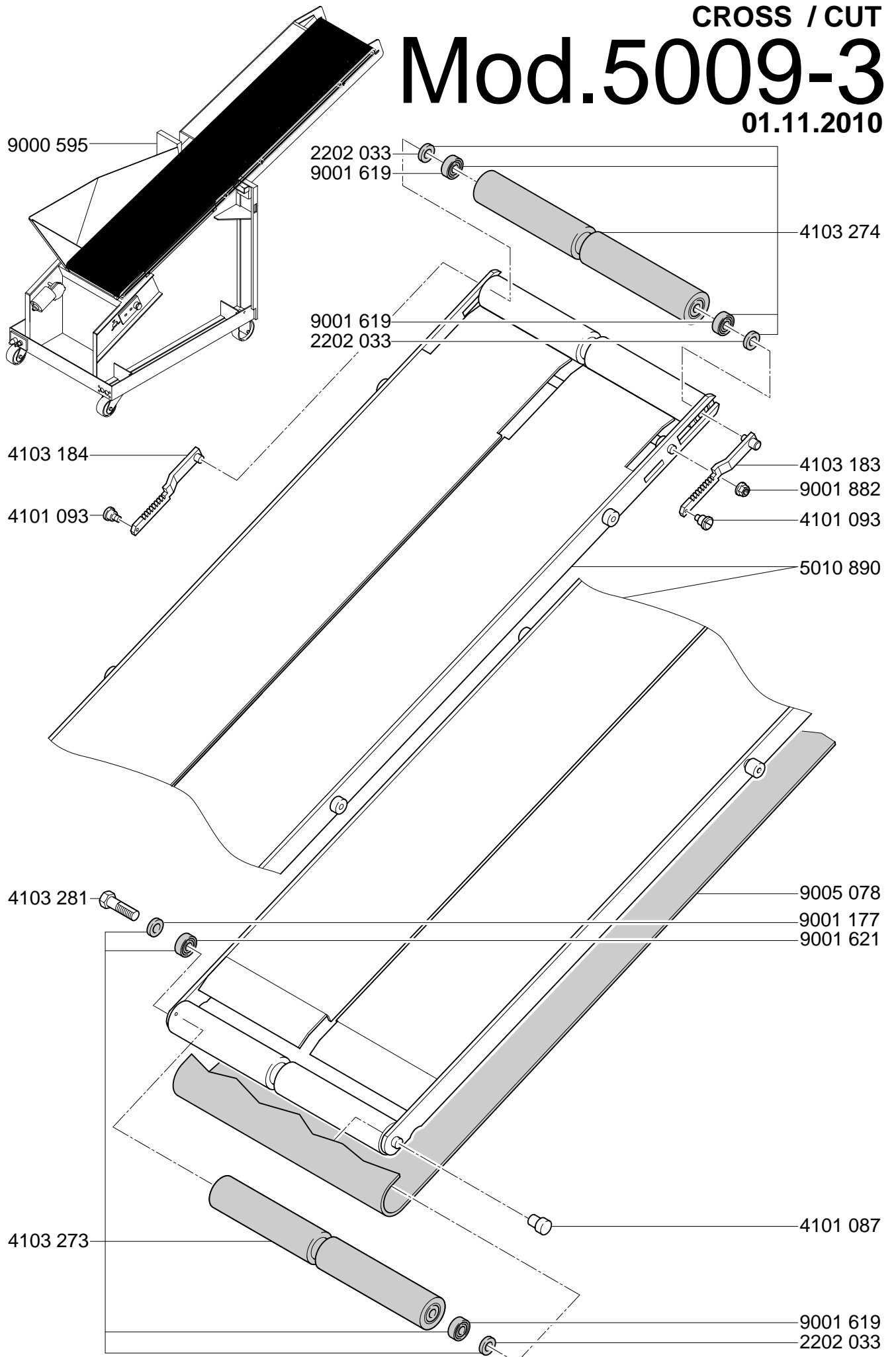

CROSS / CUT
Mod.5009-3
01.11.2010

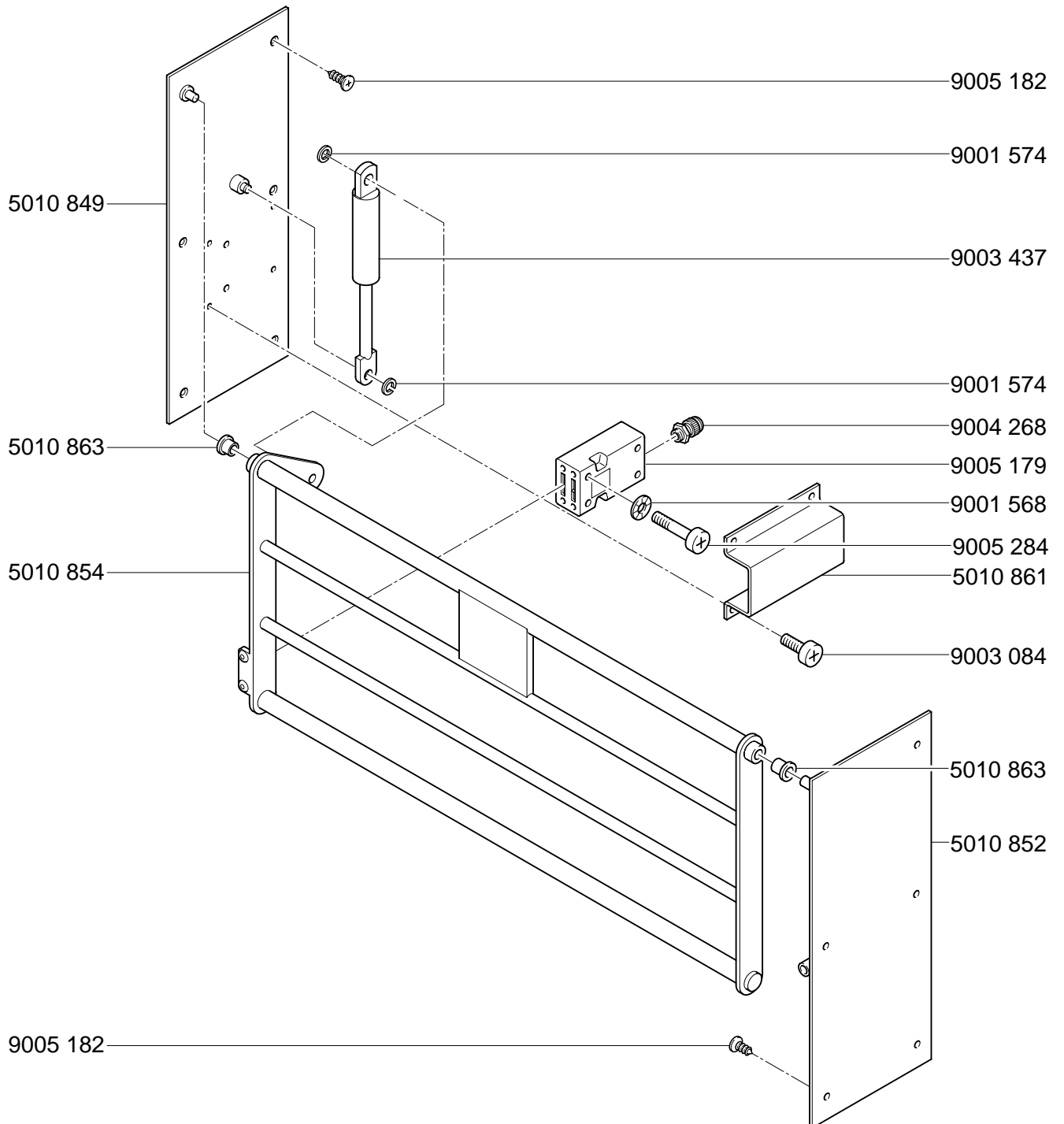
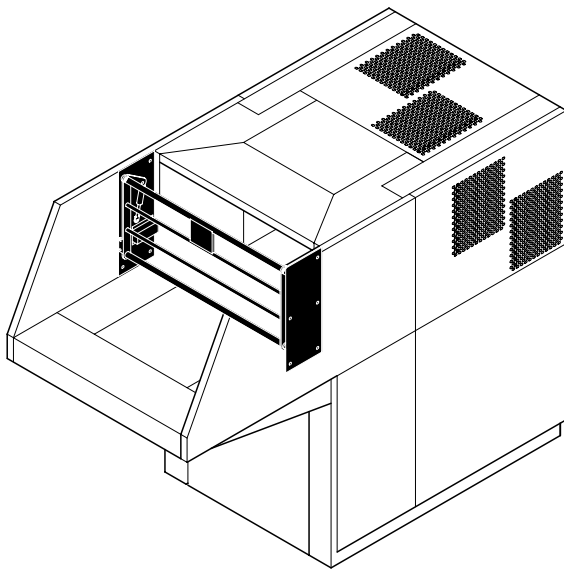

CROSS / CUT Mod.5009-3

01.11.2010
200V/220V

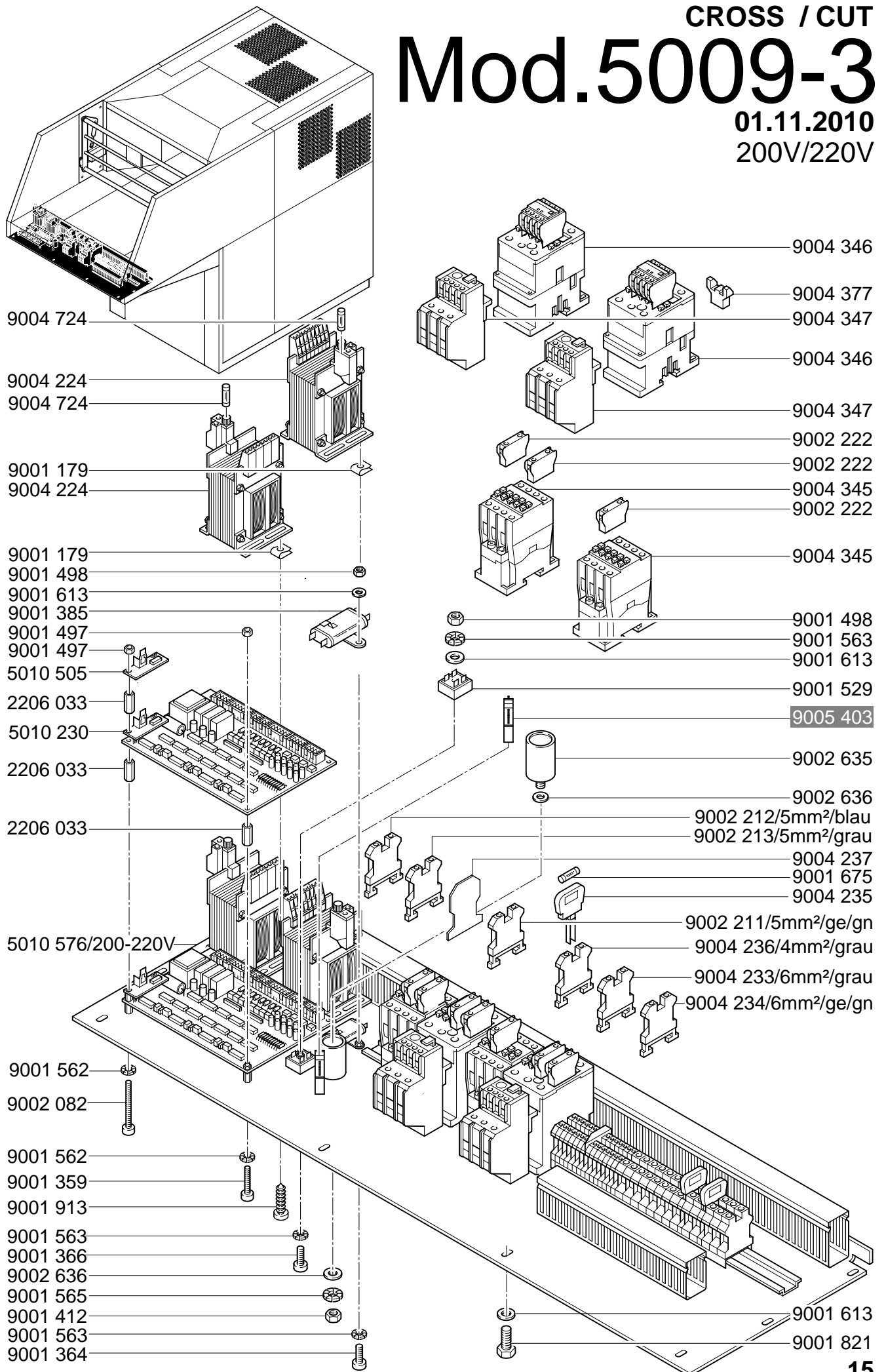

CROSS / CUT Mod.5009-3

01.11.2010
380V-460V

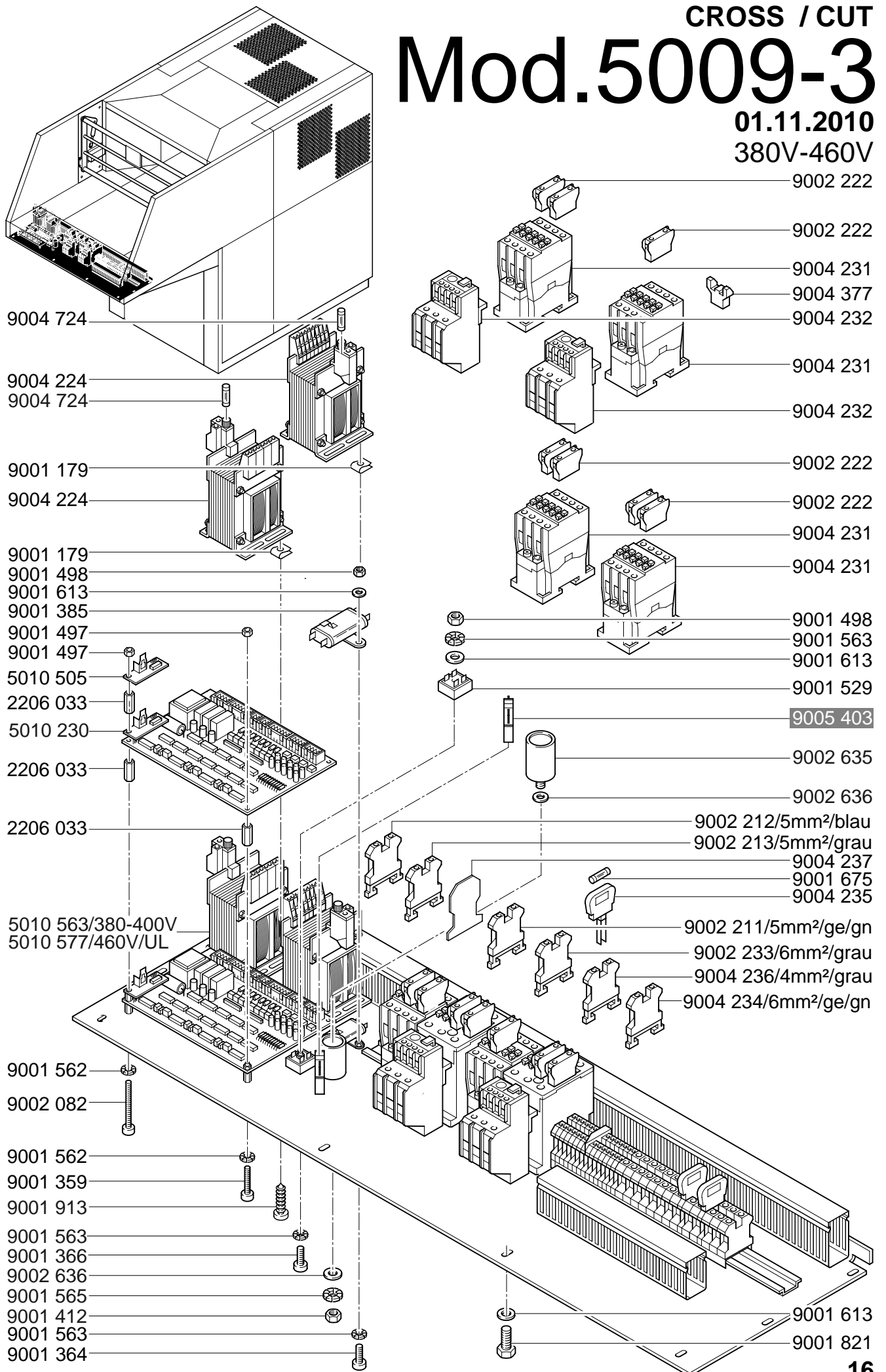

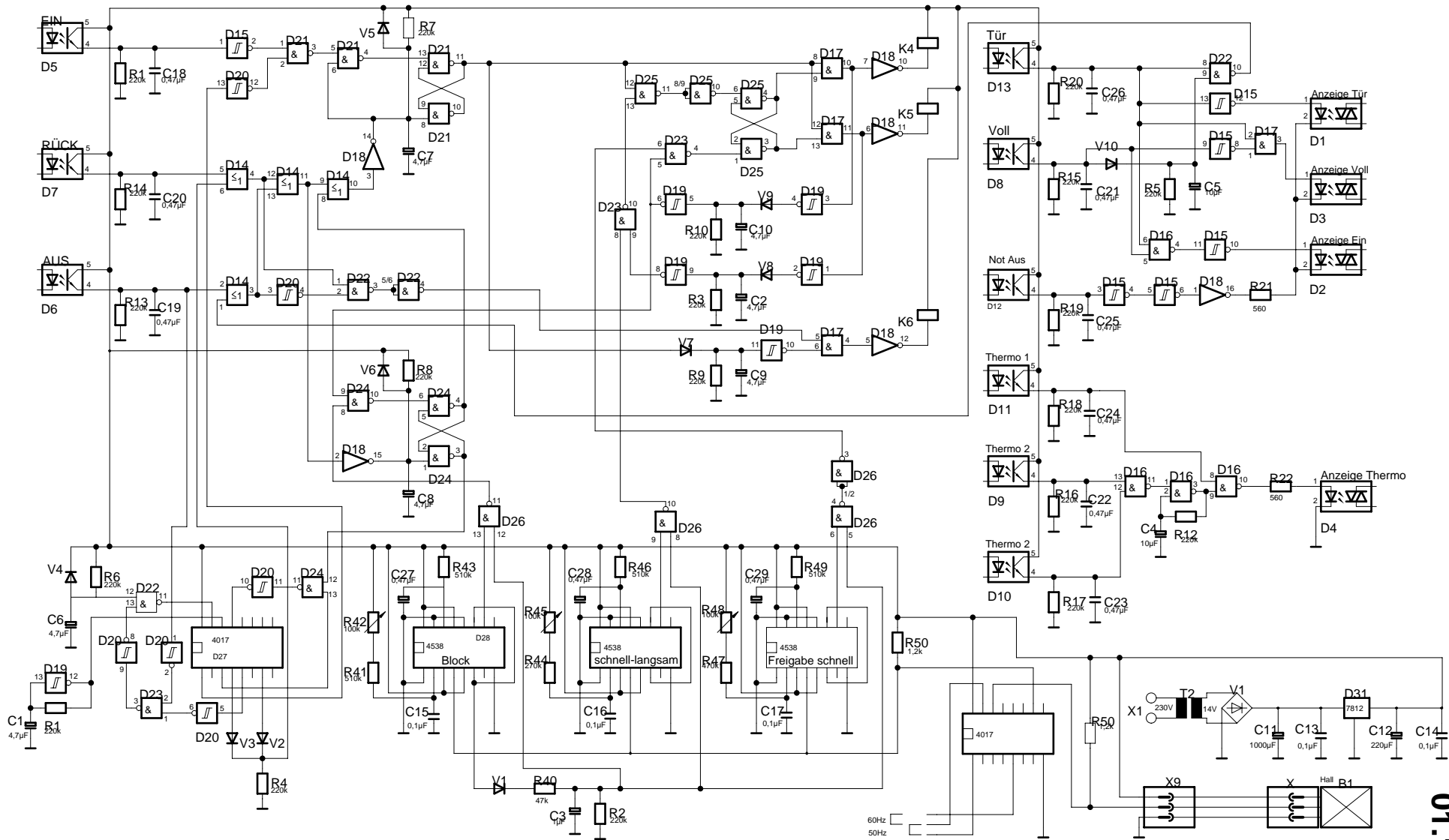

Mod. 5009-3

CROSS / CUT

01.11.2010

Stromlaufplan für Leiterplatte 5009-3
 Stromlaufplan pur Platine de Commande 5009-3
 Stromlaufplan for PC - Board 5009-3

5010 514
 17

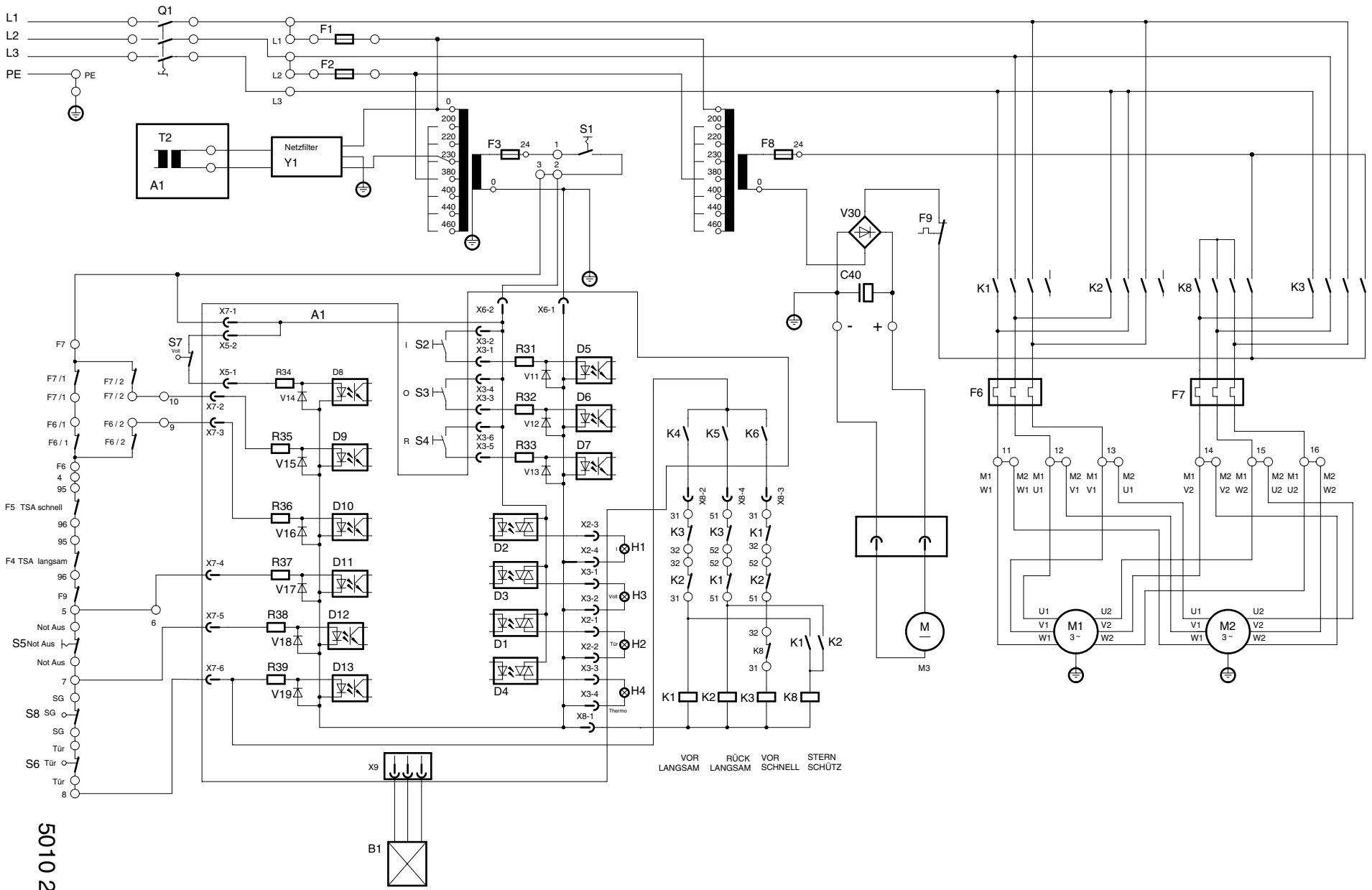

CROSS / CUT
Mod. 5009-3
 01.11.2010

Index 5009-3 / CROSS / CUT

Code	Deutsch	English	Francais	Holländisch	Italiano	Espanol
A1	Platine Steuerung	PCB - control	Platine de comande	Stuurprint	Scheda controllo	Placa de control
F1, F2	Sicherung 2,5A	Fuse 2,5A	Fusible 2,5A	Glaszekering 2,5A	Fusibile 2,5A	Fusible 2,5A
F3	Sicherung 6,3A	Fuse 6,3A	Fusible 6,3A	Glaszekering 6,3A	Fusibile 6,3A	Fusible 6,3A
H1	Kontroll Leuchte grün	Pilot light green	Voyant de contrôle vert	Controle lamp groen	Spia di controllo verde	Luz piloto verde
H2	Glühlampe weiß	Pilot light white	Voyant blanc	Gloeilamp wit	Spia bianco	Luz piloto blanco
H3	Glühlampe gelb	Pilot light yellow	Voyant Jaune	Gloeilamp geel	Spia gialla	Luz piloto amarilla
H4	Glühlampe gelb	Pilot light yellow	Voyant Jaune	Gloeilamp geel	Spia gialla	Luz piloto amarilla
F4, F5	Motorschutzrelais	Thermal fuse motor	Disjoncteur Thermique	Thermische zekering	Fusibile motore	Fusible motor
K1	Schütz vor langsam	Contacteur slow forward	Contacteur avantlent	Relais, langzaam vooruit	Relè avanti lento	Contactor marcha adelante lenta
K2	Schütz rück	Contacteur reverse	Contacteur Retour	Relais, achteruit	Relè indietro	Contactor marcha atrás
K3	Schütz vor schnell	Contacteur fast forward	Contacteur avant rapide	Relais, snel vooruit	Relè avanti veloce	Contactor marcha adelante rápida
K4, K5, K6	Relais Leiterplatte	Relay PCB	Relais Platine	Relais print	Relè PCB	Relé placa circuito
K8	Sternschütz	Star contactor	Contacteur Etorle	Relais (Ster-Driehoek)	Relè start	Contactor de inicio
M1, M2	Motor mit Getriebe	Motor	Moteur	Aandrieff motor	Motore	Motor
M3	DC - Motor mit Getriebe	DC - Motor	DC - Moteur	DC - Aandrieff motor	DC - Motore	DC - Motor
Q1	Hauptschalter	Main switch	Interrupteur principal	Hooldschakelaar	Interruttore principale	Interruptor principal
S1	Schaltenschloß	Key switch	Contacteur á clé	Sleutelschakelaar	Interruttore a chiave	Interruptor de liave
S2	Drucktaster "EIN"	Push-button on	Touche de commande marche	Drukschakelaar (aan)	Pulsante d'arresto	Botón de avance
S3	Drucktaster "AUS"	Push-button off	Touche Arvêt	Drukknop uit	Pulsante off	Botón de paro
S4	Drucktaster "RÜCK"	Push-button reverse	Touche Retour	Drukknop terug	Pulsante indietro	Botón demarcha atrás
S5	Not-Aus-Taster	Emergency cutout	Touche de commande	Noodschakelaar	Interruttore d'arresto d'emergenza	Corte de emergencia
S6	Sicherheitsschalter Tür	Saftey switch Door	Micro-contact rampe	Veiligheidsschakelaar (deur)	Interruttore di sicurezza dello sportello	Micro interruptor de seguridad puerta
S7	Schalter "Sack voll"	Switch "bag full"	Micro-contact sac plein	Schakelaar (Zak vol)	Interruttore "sacco pieno"	Micro interruptor de "bolsa liena"
S8	Sicherheitsschalter Schutzgitter	Switch safely barrier	Micro-contact grille de sécurité	Beveiligingsrooster voor schakelaar	Interruttore di sicurezza della sbare	Barrera de seguridad del interruptor
T1	Transformator	Transformer	Transformateur du circuit de commande	Transformator	Transformatore	Transformator
X9	Kfz - Stecker	Car plug	Prise de connexion	Adapter	Spina della machina	Enchufe de automovil
Y1	Netzfilter	Power line filter	Filtre Alimentation	Netfilter	Filtro linea	Filtro linea de fuerza eléctrica
Y2 - Y5	RC-Entstörglied	Arc suppressor	Antiparasite	RC ontstoorspoel	Filtro di rete	Antiparásitos

Mod. 5009-3
 CROSS / CUT
 01.11.2010