

## IDEAL 5560





- D** Bitte lesen Sie vor Inbetriebnahme der Maschine unbedingt diese Betriebsanleitung und beachten Sie die Sicherheitshinweise. Die Betriebsanleitung muss jederzeit verfügbar sein.
- GB** Please read these operating instructions before putting the machine into operation and observe the safety precautions. The operating instructions must always be available.
- F** Nous vous prions de lire attentivement le mode d'emploi avant d'utiliser la machine, et attirons votre attention sur les consignes de sécurité. Les instructions d'utilisation et les consignes de sécurité doivent toujours être disponibles. Les instructions d'utilisation et les consi.
- NL** Leest u voor de ingebruik name van het apparaat a.u.b. deze gebruiksaanwijzing goed door en neemt u de veiligheidsinstructies n acht. De gebruiksaanwijzing en de veiligheidsvoorschriften moeten altijd binnen handbereik zijn.
- I** Per favore legga questo manuale di istruzione prima di mettere in funzione il distruggidocumenti e osservi le regole di sicurezza. Le istruzioni d'uso devono essere sempre disponibili.
- E** Le recomendamos lea las instrucciones antes de poner en funcionamiento esta máquina y cumpla las normas de seguridad. Las instrucciones de servicio y seguridad deben estar siempre disponibles.
- S** Läs igenom denna bruksanvisning innan ni startar maskinen. Var noga med säkerhetsföreskrifterna. Instruktionsmanualen måste alltid finnas tillgänglig.
- FIN** Lue nämä käyttö-ohjeet läpi ennenkuin käynnistät laitteen !  
Noudata turvaohjeita. Käyttöohjeiden on oltava aina saatavilla.
- N** Lees gjennom denne bruksanvisningen før De tar i bruk maskinen  
Vær oppmerksom på sikkerhetsforskriftene. Operatormanualen må alltid være tilgjengelig.
- PL** Proszę uważnie przeczytać instrukcję obsługi przed uruchomieniem urządzenia i stosować się do przepisów bezpieczeństwa. Instrukcje obsługi muszą być zawsze dostępne.
- RUS** Пожалуйста, прочитайте инструкцию по эксплуатации перед установкой аппарата, соблюдайте технику безопасности. Инструкция по эксплуатации должна находиться в доступном для пользователя месте.
- H** A gép üzembe helyezésé előtt figyelmesen olvassa el a kezelési utasítást és tartsa be a biztonsági előírásokat. Kezelési utasításnak mindig elérhetőnek kell lennie.
- TR** Lütfen makineyi çalıştırmadan önce bu kullanma talimatlarını dikkatli bir şekilde okuyunuz ve belirtilen güvenli k önlemlerine uyunuz. Kullanma Talimatları her zaman kullanıma hazır olmalıdır.
- DK** Før installation af maskinen bedes De venligst læse brugervejledningen og være opmærksom på sikkerhedsanvisningerne. Brugervejledningen skal altid være tilgængelig.
- CZ** Prosim přečtete si instrukce k obsluze a dodržujte bezpečnostní upozornění. Návod k obsluze musí být vždy dostupný.
- P** Por favor leiam o manual de instruções antes de colocar a máquina em operação e vejã as precauções de segurança. As instruções de operação deverão estar sempre disponíveis.
- GR** ΠΑΡΑΚΑΛΩ ΔΙΑΒΑΣΤΕ ΤΙΣ ΟΔΗΓΙΕΣ ΧΡΗΣΕΩΣ ΚΑΙ ΤΙΣ ΠΡΟΦΥΛΑΞΕΙΣ ΑΣΦΑΛΕΙΑΣ ΠΡΙΝ ΒΑΛΕΤΕ ΤΟ ΜΗΧΑΝΗΜΑ ΣΕ ΛΕΙΤΟΥΡΓΙΑ. ΟΙ ΟΔΗΓΙΕΣ ΧΡΗΣΗΣ ΠΡΕΠΕΙ ΝΑ ΕΙΝΑΙ ΠΑΝΤΑ ΔΙΑΘΕΣΙΜΕΣ.
- SLO** Prosim preberite navodila za uporabo ter upoštevajte varnostna opozorila preden zaženete napravo. Navodila naj bodo vedno pri roki.
- SK** Starostlivo si preštudujte tento návod na obsluhu pred uvedením stroja do prevádzky a najmä bezpečnostné predpisy. Držte tento návod na obsluhu na dostupnom mieste.
- EST** Palun lugege enne masina käivitamist käesolevat kasutusjuhendit ning järgige ohutusnõudeid. Kasutusjuhend peab alati käepärast olema.
- CHI** 使用機器前，請閱讀此操作指引，並留意安全守則  
操作手冊必須是經常可用的。
- UAE** والامان الوقاية تعليمات ملاحظة نرجو كما الماكينة بتشغيل البدء قبل التشغيل تعليمات قراءة نرجو لا بد من وجود تعليمات التشغيل دائما



- D** Keine Bedienung durch Kinder!  
**GB** Children must not operate the machine!  
**F** Pas d'utilisation par un enfant!  
**NL** Geen bediening door kinderen!  
**I** Non lasciare utilizzare il tagliacarte a bambini!  
**E** No dejar que la utilicen los niños!  
**S** Installera maskinen utom räckhåll för barn!  
**FIN** Asentakaa laite lasten ulottumattomiin !  
**N** Installer maskinen utenfor rekkevidde for barn!  
**PL** Dzieciom nie wolno obsługiwać urządzenia !  
**RUS** Не допускайте детей к пользованию аппаратом!  
**H** Gyerekek a gépet nem kezelhetik  
**TR** Makinayı Çocuklar Kullanmamalıdır.  
**DK** Må kun betjenes af voksne  
**CZ** Stroj nesmí být obsluhováni dětmi!  
**P** As crianças não devem trabalhar com a máquina!  
**GR** ΑΠΑΓΟΡΕΥΕΤΑΙ Η ΧΡΗΣΗ ΑΠΟ ΠΑΙΔΙΑ.  
**SLO** Otroci ne smejo uporabljati naprave  
**SK** So strojom nesmú pracovať deti!  
**EST** Lapsed ei tohi masinat kasutada!  
**CHI** 勿让儿童使用机器!  
**UAE** يجب علي الأطفال عدم تشغيل الماكينة.



- D** Nicht unter das Messer fassen!  
**GB** Do not reach beneath the blade!  
**F** Ne pas passer les mains sous la lame!  
**NL** Niet met de handen onder het mes komen!  
**I** Non toccare la lama nella parte inferiore!  
**E** ¡No tocar debajo de la cuchilla!  
**S** Sträck inte in handen under kniven!  
**FIN** Älä laita kättäsi terän alle !  
**N** Plasser aldri hender ol. under kniven !  
**PL** Nie wkładać rąk pod noże!  
**RUS** Избегайте попадания рук под лезвие!  
**H** Ne nyúljon a kés alá!  
**TR** Elinizi bıçağın altına sokmayınız!  
**DK** Stik ikke hænderne ind under knivbladet!  
**CZ** Nesahejte pod ostrří nože!  
**P** Não tocar na parte inferior da faca!  
**GR** ΜΗΝ ΑΓΓΙΖΕΤΕ ΤΟ ΚΑΤΩ ΜΕΡΟΣ ΤΗΣ ΛΕΠΙΔΑΣ!  
**SLO** Ne segajte z roko pod rezilo!  
**SK** Nevkladajte ruky pod nôž!  
**EST** Ärge pange kätt tera alla!  
**CHI** 请勿接触刀具的下方。  
**UAE** لا تصل تحت السكين





- D** Messer nie lose liegen lassen!  
Messer nur mit Messerwechsellvorrichtung oder im Messertransportkasten befördern!  
(siehe Seite 26 und 28).  
⚠ **Warnung!** Verletzungsgefahr!
- GB** Never leave the blade unattended!  
Do not extract or transport the blade without protection!  
(See page 26 and 28).  
⚠ **Danger!** Risk of injury!
- F** Ne jamais laisser la lame sans protections !  
Elle ne doit être démontée qu'à l' aide du dispositif de changement de lame (cf. page 26 et 28), ou transportée dans son étui en bois !  
⚠ **Danger!** Risques de coupures !
- NL** Laat nooit de messen alleen achter.  
Transporteer de messen niet zonder de houten bescherming (zie pagina 26 en 28).  
⚠ **Waarschuwing!** Opgelet voor ongevallen!
- I** Non lasciare mai la lama incustodita. Non rimuovere o trasportare la lama senza protezione. (Vedi pagina 26 e 28).  
⚠ **Attenzione!** Rischio di infortunio!
- E** ¡No quitar la cuchilla sin prestar atención. No desmontar no transportar la cuchilla sin protección! (vérase pág. 26 y 28)  
⚠ ¡**Advertencia!** ¡Peligro de hacerse daño!
- S** Lämna aldrig maskinen obemannad. Ta inte ur eller transportera kniven utan skydd. (se sid 26 och 28).  
⚠ **Skaderisk!**
- FIN** Käsittelle terää aina varoen. Älä siirrä tai kuljeta terää ilman suojaa ! (katso sivu 26 ja 28)  
⚠ **Loukkaantumisen vaara !**
- N** La aldri kniven ligge ubeskyttet. Ta aldri ut kniven eller transporter den uten beskyttelse (Se side 26 og 28)  
⚠ **FARE !** Muligheter for skade !
- PL** Nigdy nie pozostawiać noży bez nadzoru.  
Nie wyciągać lub transportować noży bez osłon!  
(zobacz strona 28 i 30).  
⚠ **Ryzyko skaleczenia sie!**
- RUS** Не оставляйте открытое лезвие без присмотра! Не пытайтесь извлечь или транспортировать лезвие без специальных мер предосторожности!  
(См. страницы 26 и 28)  
⚠ **Соблюдайте выше перечисленные правила для избежания травм!**
- H** Soha ne hagyja a kést őrizetlenül!  
Ne vegye ki vagy ne szállítsa a kést védőtok nélkül!  
(Lásd 26. és 28. oldal)  
⚠ **Veszély!** Sérülésveszély!
- TR** Bıçağı hiçbir zaman gözetimsiz bırakmayınız!  
Bıçağı muhafazasız olarak yerinden çıkartmayınız veya taşımayınız! (Sayfa 26 ve 28'e bakınız)  
⚠ **Dikkat!** Yaralanma riski!



- DK** Knivbladet må aldrig efterlades uden opsyn.  
Forsøg ikke at afmontere eller transportere knivbladet uden beskyttelse! (Se side 26 og 28)  
⚠ **FARE! Risiko for legemlig beskadigelse.**
- CZ** Nikdy nenechávejte nůž bez krytu.  
Nikdy nevyjímejte nebo neprepravujte nůž bez ochranného krytu (viz. strany 26 a 28)  
⚠ **Nebezpečí! Riskujete zranění**
- P** Deixar a faca sempre em local seguro!  
Não retirar ou transportar a faca sem protecção!  
(Ver pág. 26 e 28)  
⚠ **Perigo! Risco de dano!**
- GR** ΜΗΝ ΑΦΗΝΕΤΕ ΤΗΝ ΛΕΠΙΔΑ ΑΝΕΠΙΤΗΡΗΤΗ!  
ΜΗΝ ΑΜΛΑΖΕΤΕ Ή ΜΕΤΑΦΕΡΕΤΕ ΤΗΝ ΛΕΠΙΔΑ ΧΩΡΙΣ  
ΠΡΟΦΥΛΑΞΗ (Δείτε σχετικά στις σελίδες 26 & 28)  
⚠ **ΠΡΟΣΟΧΗ ! ΚΙΝΔΥΝΟΣ ΤΡΑΥΜΑΤΙΣΜΟΥ !**
- SLO** Nikoli ne puščajte rezila nazaščitenega. Nikoli ne prenašajte  
rezilo brez zaščite. (glej stran 26 in 28).  
⚠ **Pozor! Nevarnost poškodbe.**
- SK** Nenechávajte nôž nechránený (nezabezpečený)!  
Nevyberajte alebo netransportujte nôž bez ochrany  
(vid s. 26 a 28)  
⚠ **! Riziko úrazu !**
- EST** Ärge jätke lõiketera kunagi järelevalveta!  
Ärge pikendage ega teisdaldate tera kaitseseadmeteta!  
(Vt lk 26 ja 28)  
⚠ **Oht! Vigastuste oht!**
- CHI** 在没人留意的情况下，请勿离开刀具。  
在没有保护的情况下，请勿取出或运送刀具！（参阅第 26 和 28 页）。  
⚠ 危险！可引致受伤！
- UAE** لا تترك السكين بدون اهتمام  
لا تخرج أو تنقل السكين بدون حماية ( انظر صفحة 26 و 28 )  
⚠ خطر ! التعرض للآذى

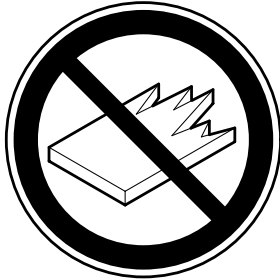

- D** Keine harten und splitternden Materialien schneiden!
- GB** Do not cut hard materials or materials which may splinter!
- F** La coupe de matériaux trop durs ou risquant des projections est interdite !
- NL** Snij geen harde materialen of materiaal dat kan splinteren!
- I** Utilizzare il tagliacarte esclusivamente per il taglio di risme di carta o materiali analoghi!
- E** ¡No cortar materiales duros o materiales que puedan astillarse!
- S** Försör inte hårt material eller material som kan splittras!
- FIN** Asentakaa laite lasten ulottumattomiin !
- N** Ikke kutt hardt metall eller materiale som kan splintre !
- PL** Nie ciąć twardych materiałów lub materiałów, które mogą ulec odprysnięciu!
- RUS** Данный резак не предназначен для резки твердых материалов или материалов, которые могут расщепляться!
- H** Ne vágjon kemény vagy olyan anyagot, amely repedhet!
- TR** Sert veya parçalanabilecek malzemeleri kesmeyiniz!
- DK** Der må ikke skæres i hårde materialer eller i materialer, der kan splintre!
- CZ** Neřežte tvrdý materiál, při kterém mohou ustřelovat ostré úlomky!
- P** Não cortar materiais duros ou materiais que possam lascar!
- GR** ΜΗΝ ΚΟΒΕΤΕ ΣΚΛΗΡΑ ΥΛΙΚΑ Ή ΥΛΙΚΑ ΠΟΥ ΘΡΥΜΜΑΤΙΖΟΝΤΑΙ!
- SLO** Nikoli ne režite trdih materialov ali materialov, ki se lahko razcepijo.
- SK** Nerežte tvrdé materiály, alebo materiály, z ktorých môžu vystrelovať ostré úlomky.
- EST** Ärge lõigake kõvasid materjale ega materjale, mis võivad pilbasteks puruneda!
- CHI** 请勿切割坚硬或可裂成碎片物料。
- UAE** لا تقطع الأشياء الصلبة أو الأشياء التي يتطاير منها شظايا!

• Safety precautions •

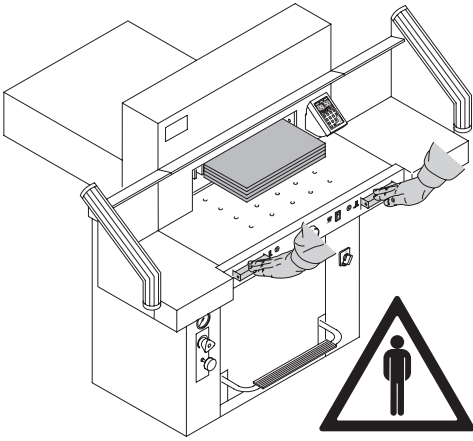

The machine is designed for cutting stacks of paper to a specified size. This machine is constructed for "one-man operation" only!  
⚠ **Warning!** Clips or similar damage the cutting blade.

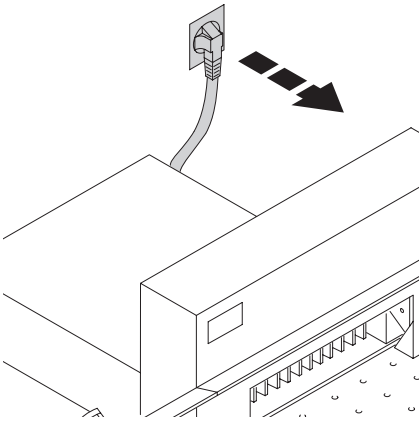

Disconnect from the mains before starting any service work or before removing the panels!

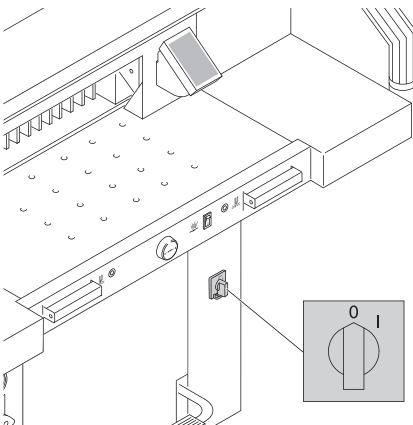

Replacement of blade and cutting stick may be performed only when the main switch is switched off!

## IDEAL 5560

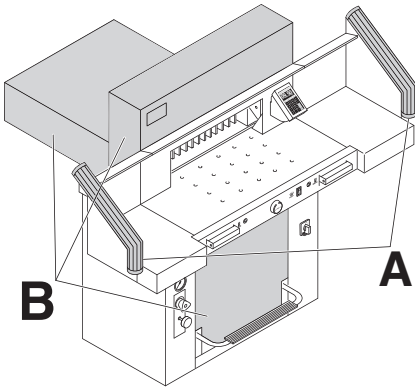

All components which could endanger the operator are covered by a guard **(B)**!

Do not operate the machine without the following safety devices:

- Safety beam guard **(A)**
- Panels, tightly screwed **(B)**.

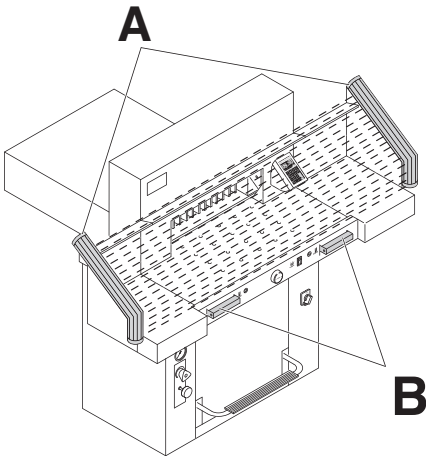

The cutting action, which is dangerous to the operator, is protected by a two-handed control system **(B)** and safety beam guard **(A)**.

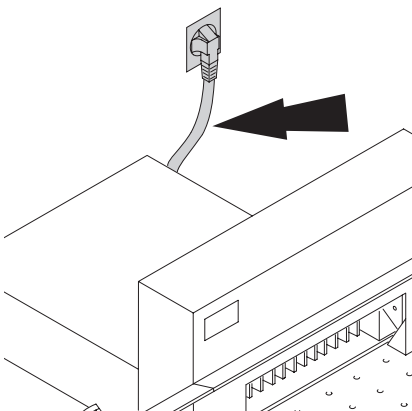

Protect mains cable against heat, oil and sharp edges!

Standard machines are factory-set as follows:

- Voltage 230 V (120 V) 1 phase
- Frequency 50 Hz (60 Hz).



• Safety precautions •

When not in use for a longer period switch off. (Main switch to "0").

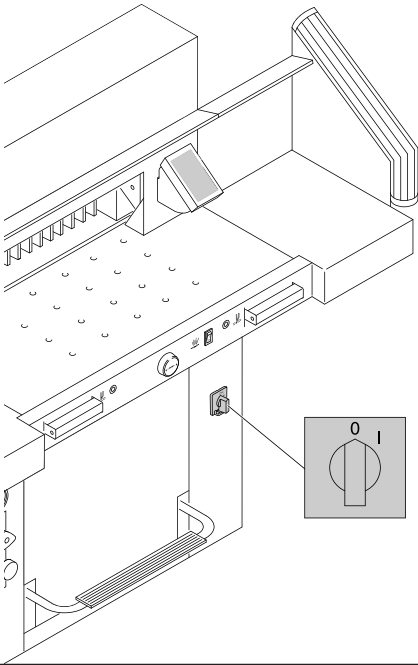

**⚠ Danger!**  
Blade must always be covered by the pressing bar.

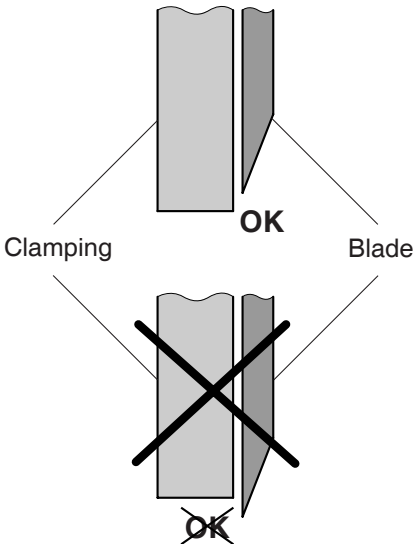

IDEAL 5560

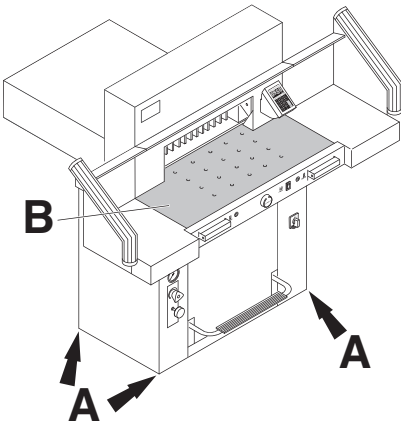

The machine is mobile on castors. Align the machine as follows:

- Align machine with water level and adjust accordingly.
- Reference area machine table (B).

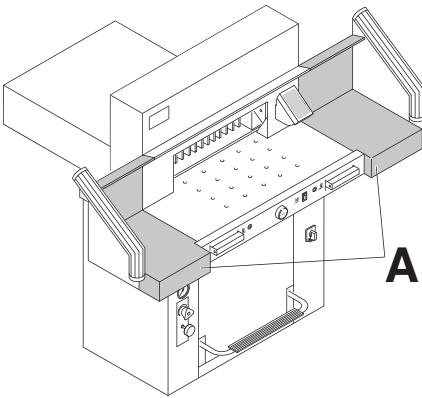

The machine is delivered ready for operation. Side tables (A), left and right are available as an option. Assembly instructions are included.

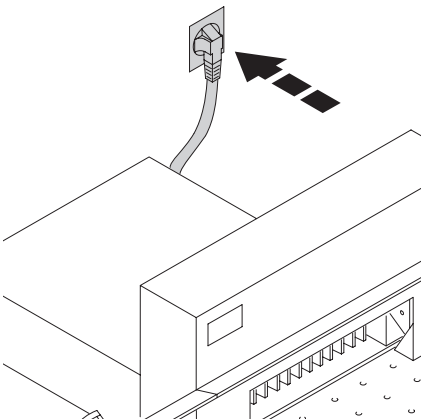

Plug into socket.

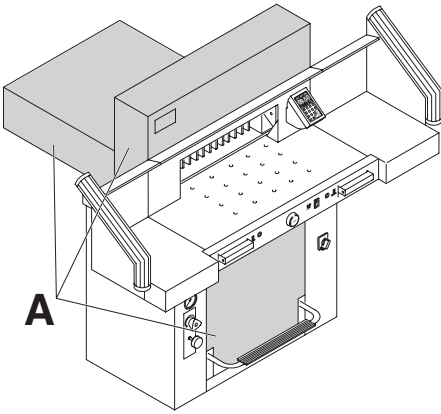

It is forbidden to operate the machine if the operating and safety instructions have not been understood. Please check the safety devices are functioning and complete before use.

- All covers have to be mounted (A).

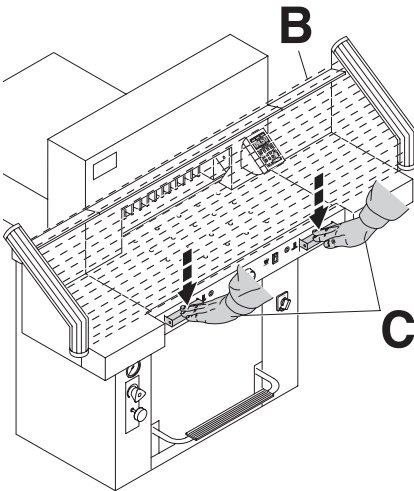

- The release for cutting is allowed only if the two-hand safety device is operated at the same time (C).
- The machine stops immediately if anyone reaches into the cutting area (B).

We recommend you keep a record of your test results.

IDEAL 5560

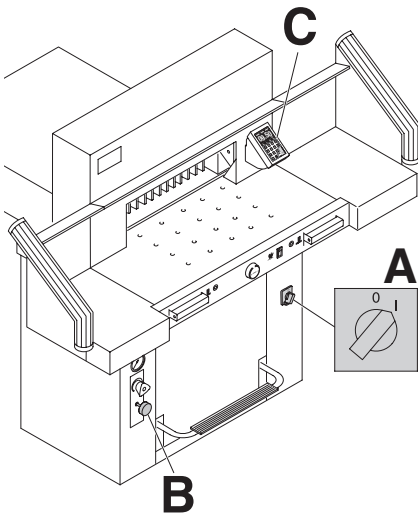

Position the main switch to "I" (A).  
 Blade locking facility (B) must be pulled out.  
 Press  button (C). → Machine will  
 automatically go to the start position.  
 The machine is now ready for use.

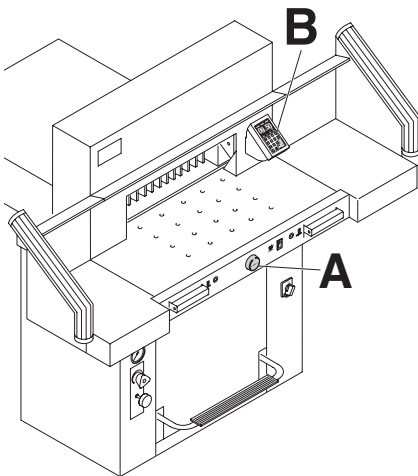

The measurement is set either with the  
 handwheel (A) or by programming (B) the  
 cutting measurements. Measurement is  
 shown on the display in inches or cm (B).

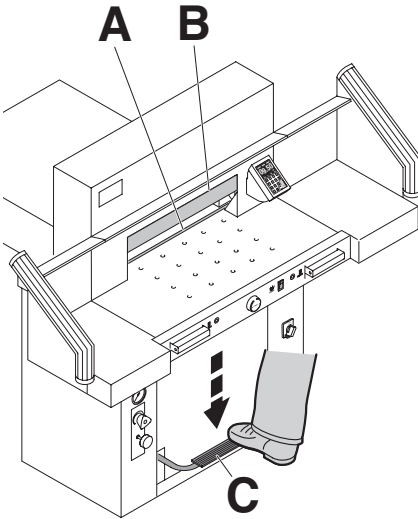

**Optical cutting line indicator:**

Optical cutting red line (A), indicates the position of the cut. Blade cuts on the front edge of the light beam.

**Mechanical cutting line indicator:**

The clamp (B) can be used as cutting line indicator for cutting. Pre-clamping can be performed using the foot pedal (C).

Only use the optical cutting line indicator and mechanical cutting line indicator when no exact cut is required.

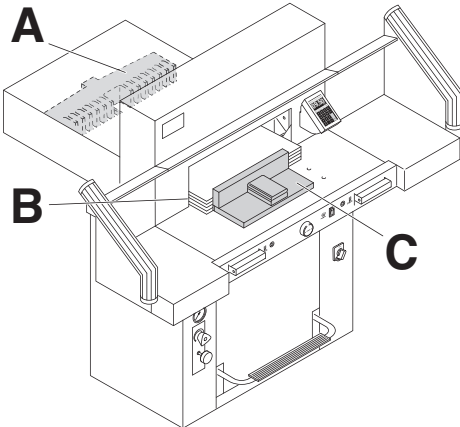

Position the paper on the backgauge (A) and side lays left or right (B). To move paper stacks, please use the paper knock-up block (C) provided. (Run backgauge to the front for turning the paper stack).

IDEAL 5560

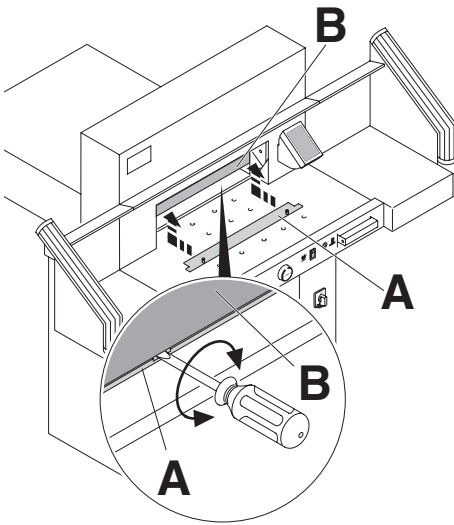

**Clamp plate:**

A clamp plate (A) is fitted to the machine to prevent pressure marks on sensitive material.

**To dismantle:**

- Remove the clamp plate (A) by turning the screwdriver (found in tool box) in the space between the clamp and clamp plate.  
→ The remaining cut is 3,2 cm.

**To mount:**

- The clamp plate (A) is inserted to the top into the clamp (B).  
→ The remaining cut is 6 cm.

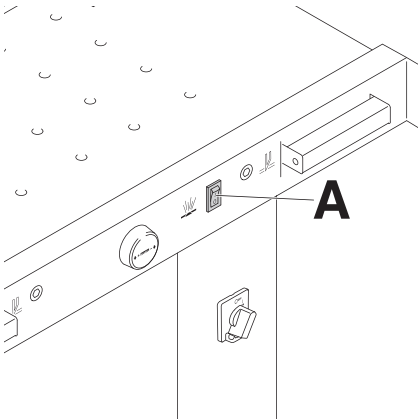

**Air table**

It is easier to position large stacks of paper when the airtable (A) is switched on.

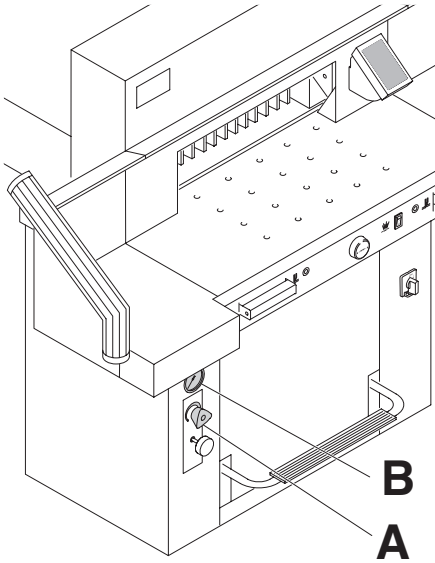

### Setting clamping pressure

If necessary, set clamping pressure with setting wheel (A). If a cutting process has been activated, the oil pressure can be seen on the oil pressure indicator (B).

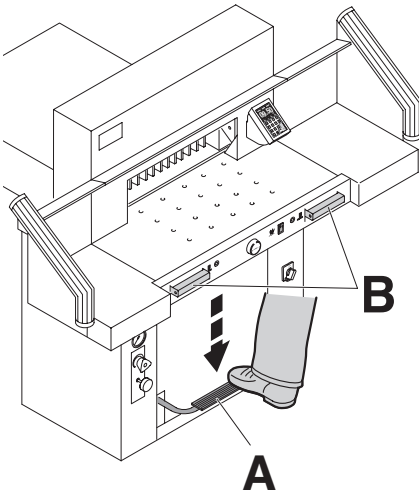

The clamp moves automatically when cutting is activated. The paper can be pressed in advance, with the foot pedal (A). Cutting is activated by pressing both buttons (B) on the front table.

IDEAL 5560

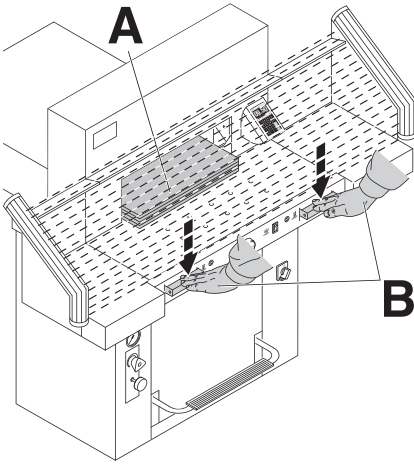

**Cutting activation**

Do not reach into the cutting area when the blade is in motion.

A cut can only be activated when the specified size is approached.

- Release the photo-electric beam guard (A).
- Press both actuators of the safety two-handed control system (B) simultaneously and keep them pressed until the paper is completely cut.

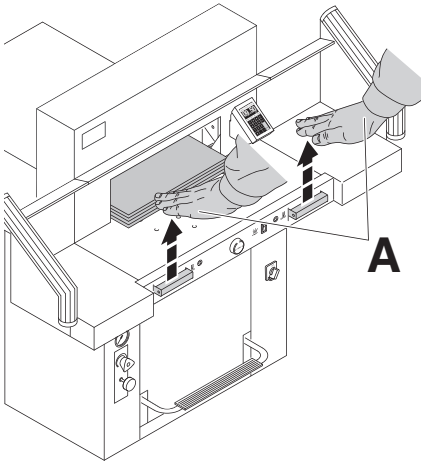

**Cutting stop or interruption:**

Release both actuators of the two-hand control (A).



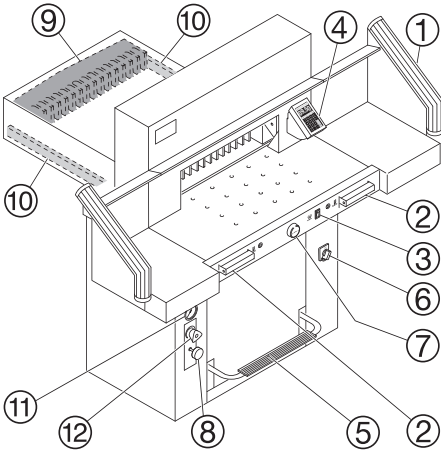

### Operating elements

- ① - Safety light beam
- ② - Safety two-handed control system clamping and cutting
- ③ - Air table On-Off
- ④ - Backgauge control
- ⑤ - Foot pedal
- ⑥ - Main switch
- ⑦ - Hand-wheel for backgauge setting
- ⑧ - Blade locking
- ⑨ - Backgauge
- ⑩ - Side lay left and right
- ⑪ - Clamp pressure
- ⑫ - Clamp pressure adjustment

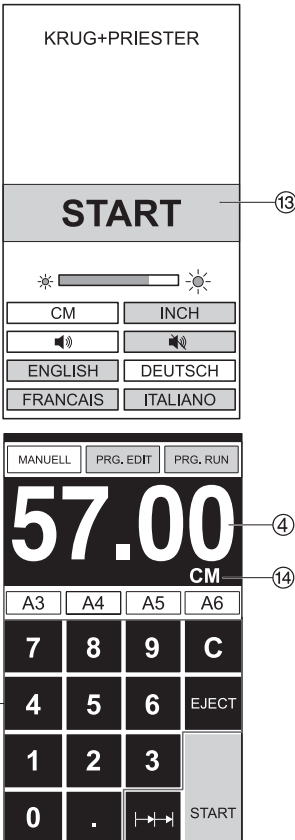

### Start machine

- Main switch ⑥ to position "I".  
Start screen appears  
The following functions are changeable:  
Brightness  
CM/INCH  
Touchtone ON/OFF  
Language
- Press START ⑬ → backgauge ⑨ moves to the rear and searches for the reference position, wait until a measurement is shown in the display ④  
IDEAL 5560 = 57 cm, 22.44 inches
- The DIN measurements in cm (A3, A4, A5, A6) and in inch (LD, LG, LT, hLT) are recallable with the respective buttons.

### ⚠ Warning!

Before storing or cutting a measurement please check if the correct measurement scale (cm or inch) see above is stored. For information on how to store see picture below left  
Is shown on the screen see ⑭.

After 30 minutes the screen switches to energy-saving mode  
The screen is reactivated by touching the keypad area ⑮.

IDEAL 5560

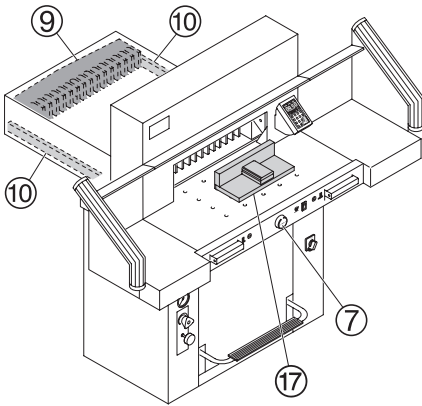

**Cutting activation**

**⚠ Warning!**

- Run backgauge to the front for turning the paper stack
- Do not interrupt the upward movement of the blade by performing switching procedures
- Wait until the display is green before activating a cut
- Blade must always be at the top and be covered by the clamp. Do not touch the blade (see safety information on page 33).

**⚠ Risk of injury!**

**Cutting to specified dimensions**

- Press **MANUAL**
- Enter dimension on the numerical key pad **15**  
→ Measurement is shown in red  
(If a wrong dimension is entered this can be corrected by pressing the **C** button)
- Press **START** **16** → dimension is approached, → Measurement is shown in green
- Insert paper and move by means of the stacking angle **17** to the backgauge **9** and side lay on the left **10**
- Release the cut.

**Cut according to markings**

Press **MANUAL**

- Adjust the backgauge with the hand-wheel **7** to the back
- Insert paper and move by means of the stacking angle **17** to the backgauge **9** and side lay on the left **10**
- Turn the hand-wheel **7** to the right until the marking on the paper to be cut is below the cutting line indicator
- The further the hand-wheel **7** is turned to the right, the quicker the backgauge moves. If the hand-wheel is turned to the left the backgauge will return quicker.

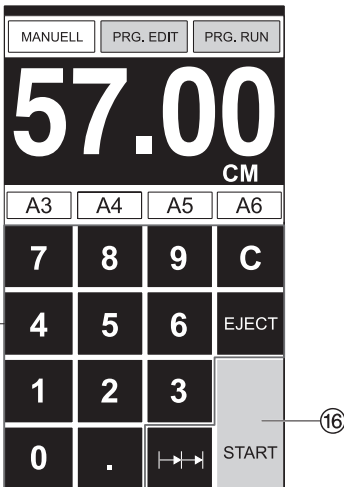

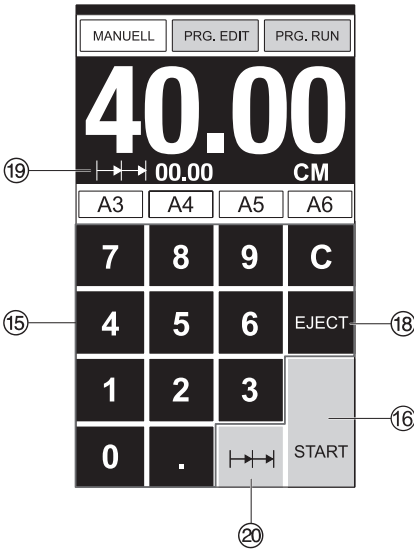

## Eject function

If EJECT (18) is pressed instead of START (16), after inserting the measurement (15), the backgauge will advance forwards so that paper can be removed. Finally the backgauge moves to the last setting.

## Multiple cut

- Enter the start dimension on the display (15)
- Advance to the measurement with the START (16)
- Push the paper to the backgauge (9)
- Press multiple cut (20)
- Multiple cut sign appears top left together with the value 00.00 (19)
- Enter multiple cut measurement (appears in red letters)
- Press START → the backgauge advances by the multiple cut size
- This is repeated everytime a cut is activated.

## Exiting program-mode

- Press multiple cut (20) (yellow).  
Multiple cut sign and value are deleted.

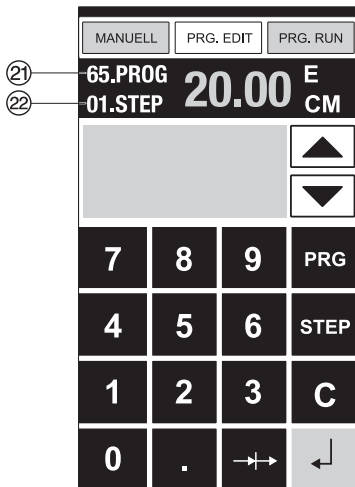

## Programming

This control system enables you to store 99 programs with 99 programmable steps. One step represents one measurement. After entering the program numbers you are able to change between several program steps with the button and .

First figure on display ②① = program number.  
Second figure on display ②② = program step.

Each program step corresponds to one dimension. The indicated program step can be overwritten at any time. These programs remain stored when the machine is off.

### Entering a program

- Press **PRG. EDIT** → "Load program no." appears
- Enter program number 01 ... 99, with (Top number ②① on display = program number)
- If measurement is shown on the display the program is reserved, select another program
- Program step "01 Step" 00.00 ②② appears. (Second figure on display ②② = program step.)
- Enter dimension, or move the backgauge to the desired measurement with the hand-wheel ⑦
- Store the measurement , next program step appears.
- Enter the next measurement and with Enter store the measurement etc.
- Should the entered program be required immediately → press **PRG. RUN**
- Press Enter
- Press START
- Escape the program mode press **MANUAL**

### Cancel a program

- Press **PRG. EDIT**
- Scroll with PRG until "Delete program no." appears
- Enter Program number
- Press Enter
- Press Enter

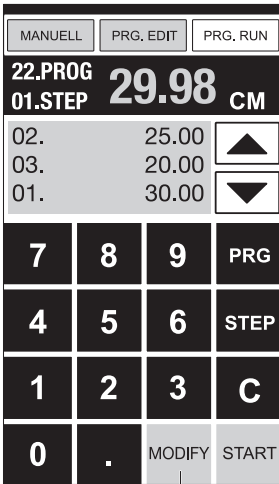

### Adapting a program when the printer's imprint deviates

- Press **PRG. RUN** → "Load program no." appears
- Enter program number 01 ... 99, and with 2 x Enter ↵ proceed to Step 1
- Correct the cutting position of the backgauge with the hand-wheel
- **MODIFY** Ⓜ appears on the screen and the measurement flashes
- To store press **MODIFY**
- Release a cut and turn the paper
- If the printer's imprint deviates it can be corrected during the first two cuts via the hand-wheel – see above
- Correction is only possible during the first two cuts
- After leaving the **PRG. RUN** mode the original data is stored again.

### Delete a step

- Press **PRG. EDIT**
- Enter program number, confirm with Enter ↵
- Select program step with the arrow keys ▲ and ▼
- Scroll with **STEP** until "Delete step no." appears, Press 2 x Enter ↵.

### Insert a step

- Press **PRG. EDIT**
- Select a program, confirm with Enter ↵
- Scroll with **STEP** until "Insert step no." appears
- Enter insert position e.g. 02
- Confirm with Enter ↵
- Enter a measurement
- Store the measurement with ↵
- The cutting position can be shown on the screen with the arrow keys ▲ and ▼.

### Changing a program step

- Press **PRG. EDIT**
- Select a program, confirm with Enter ↵
- Scroll with **STEP** until "Load step no." appears
- Enter step position e.g. 03
- Confirm with Enter ↵
- Enter a new measurement, Store the measurement with ↵.

IDEAL 5560

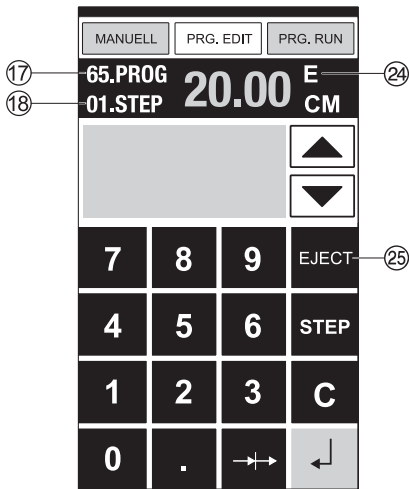

**Eject function program**

- If a short measurement e.g. 30 cm and then a long measurement e.g. 40 cm is cut at the start of a program then it is wise to insert an EJECT 24 after the first cut so that the paper is pushed to the front.
- The EJECT function can be added each time a measurement is entered and ejects before advancing to the next measurement. When the eject function is programmed an "E" 24 appears top right in the display.
- Inserting an Eject function subsequently in the program. Select a program and advance to the step to be changed with the arrow keys ▲ and ▼ Enter the new measurement and before activating the enter button ↵ press EJECT 25.

**Example of a program eject function**

- Press PRG. EDIT
- Enter program number e.g. 08
- Press Enter ↵
- 1. Enter program Step e.g. 30 cm
- Press Enter ↵
- 2. Enter program Step e.g. 40 cm
- Press EJECT and with Enter ↵ store the dimension.

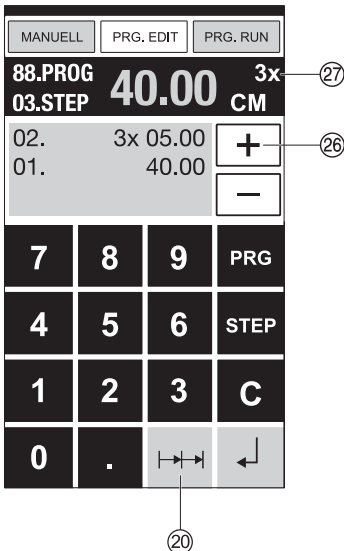

**How the example works**

- Press PRG. RUN
- Enter program number 08
- Press Enter ↵
- Press START, Measurement is approached
- Insert paper
- Release cut 1
- Eject (Ejection is completed, turn the paper)
- The backgauge moves to program step 2
- Release cut 2

**Multiple cut program**

- Press PRG. EDIT
- Enter program number
- Enter the 1. program step e.g. start-up measurement 40 cm
- Store the measurement with Enter ↵
- Press the multiple cut symbol ⇄ 20
- Enter the number of cuts 26 with the + button 27 (max. 15 cuts) followed by the multiple cut size (cutting width).
- Store with Enter ↵.

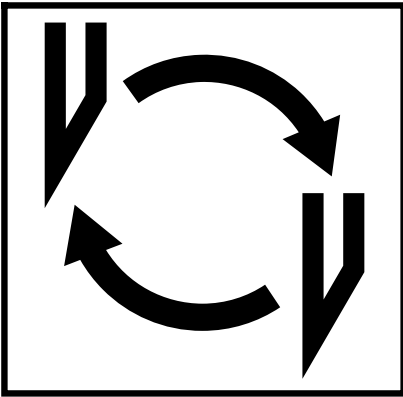

**If the cutting quality decreases:**

- Check the cutting depth (see page 33).
- Check the cutting stick (see page 27).
- Replace or grind the blade (see page 23 - 33).

**The blade cannot be ground if the blade height is less than 8,2 cm / 3,23 inches.**

**A new blade must be used.**

The blade may only be ground by a qualified supplier or from the manufacturer Krug & Priester, D-72336 Balingen.

**⚠ Danger! Risk of injury!**

**The blade is extremely sharp. Do not extract or transport the blade without protection. Changing the blade may only be performed by trained staff.**

**IDEAL 5560**

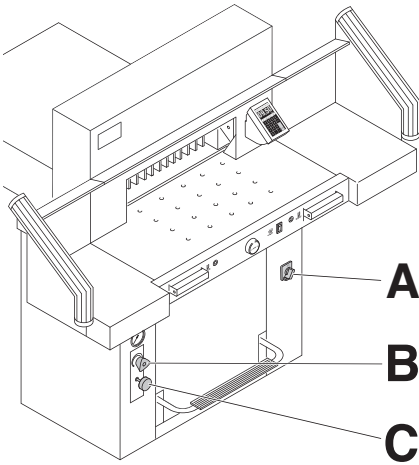

- Set mains switch (**A**) to position "I" .
- Set clamping oil pressure (**B**) to min. 50 bar.
- Press in blade locking key (**C**).
- Activate cutting → blade remains in lowest position.
- Set mains switch to position "0".

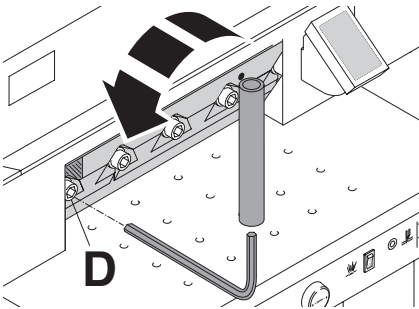

Remove the left screw (D), using the extension.

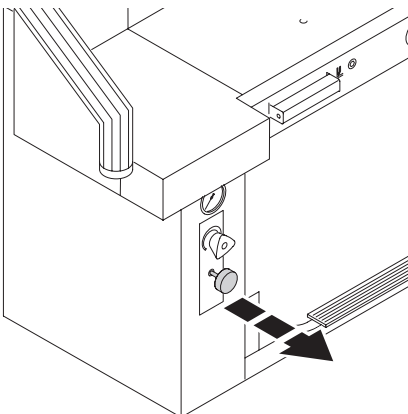

Pull out blade locking key → blade moves to the top.



• Blade and cutting stick replacement •

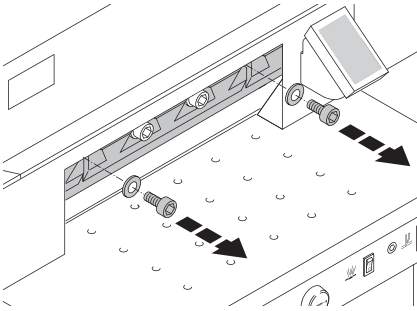

Remove both outer screws.

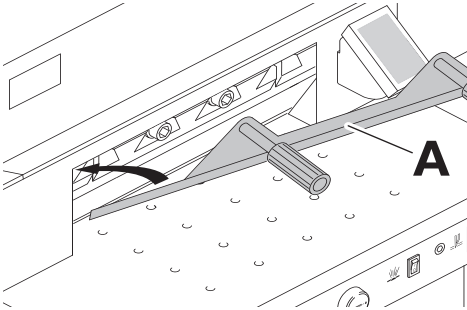

Mount blade changing tool (A).

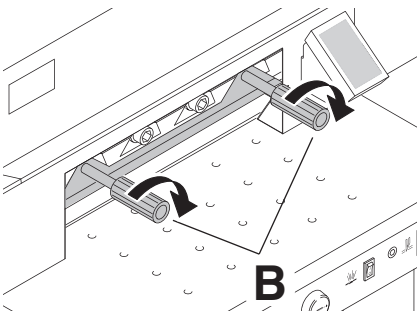

Tighten screws (B).

IDEAL 5560

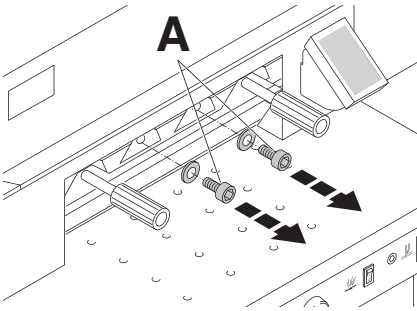

Remove remaining two screws (A).

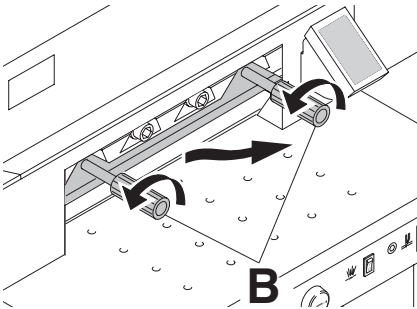

Simultaneously slightly loosen both screws (B) and remove blade with blade changing tool.

**Weight of blade approx. 5 kg.**

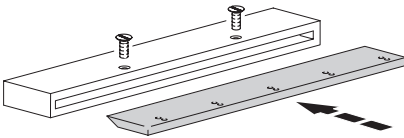

Place the blade into the blade carrier and screw it into place.

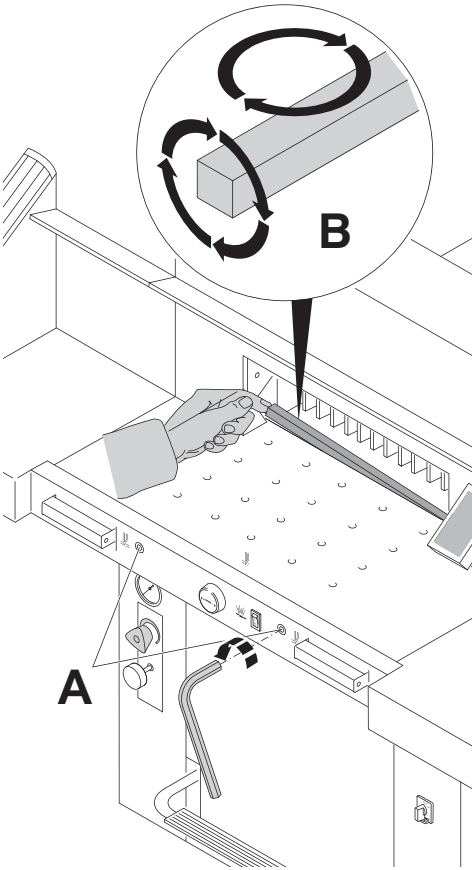

- Loosen screws (A) (SW4).
  - Remove cutting stick (B).
  - If needed the cutting stick can be turned or exchanged.
  - Slightly tighten screws (A).
- The cutting stick can be used eight times.
- Turn screw (C) as far as possible to the right (Otherwise the first cut will be too deep).

⚠ **Danger! Risk of injury!**

### Replacing the cutting stick (not the blade)

- Loosen screws (A) (SW4).
- Remove cutting stick (B).
- Turn the cutting stick (the non-used side must be near to the blade).
- Slightly tighten screws (A).
- Turn screw (C) as far as possible to the right (Otherwise the first cut will be too deep).

⚠ **Danger! Risk of injury!**

### Cutting test after replacing the cutting stick (not the blade)

- Insert the paper and release the cut.
- If the last sheet of paper is not cut along the entire length turn the blade adjusting screw (C) 1/6 turn to the left.
- If the last sheet is still not completely cut repeat this process until the last sheet is cut along the entire length.

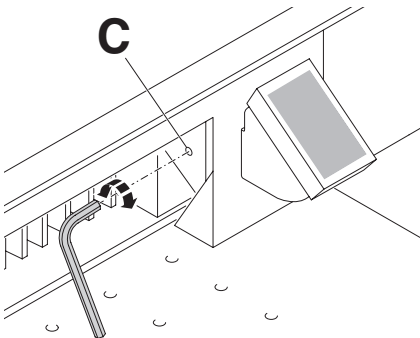

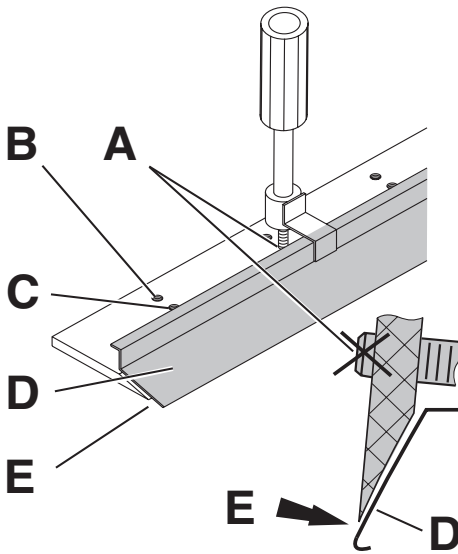

Take the exchange blade carefully out of the blade box and screw it to the blade changing tool (D).

- Check, if when using the upper threads (B), the blade (E) is protected.
- The blade is not protected → Use the lower thread (C) for fixing. The screws (A) may not exceed at the rear side of the blade.

**⚠ Danger!**

Blade (E) must be protected.

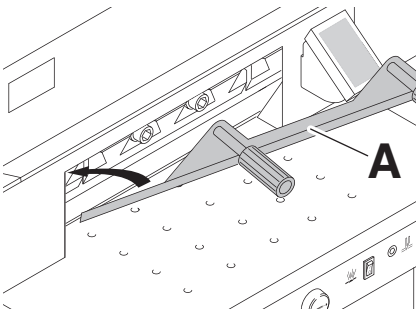

Mount the blade with the blade changing tool (A) ...

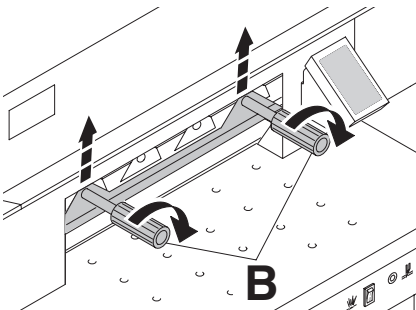

... and tighten with screws (B) in upper position.

**Blade must be in the upper position.**

• Blade and cutting stick replacement •

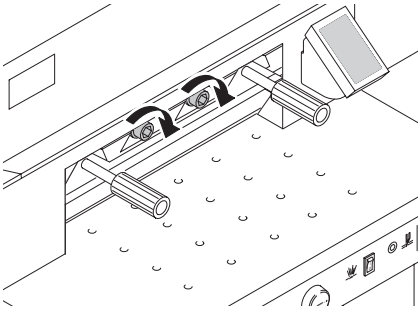

Screw in middle screws and tighten.

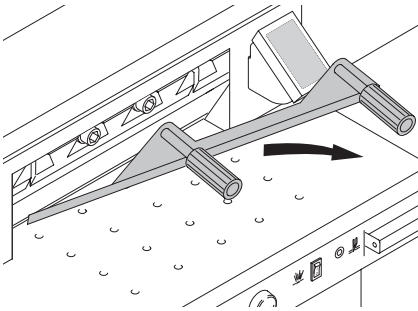

Remove the blade changing tool.

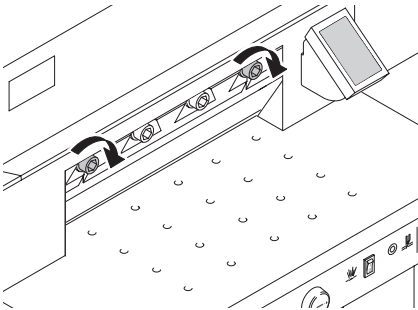

Slightly screw in outer screws.

IDEAL 5560

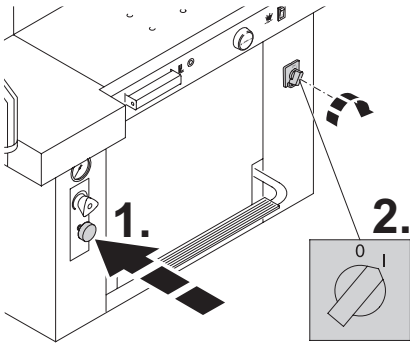

- Press in blade locking key.
- Set main switch to position "I".

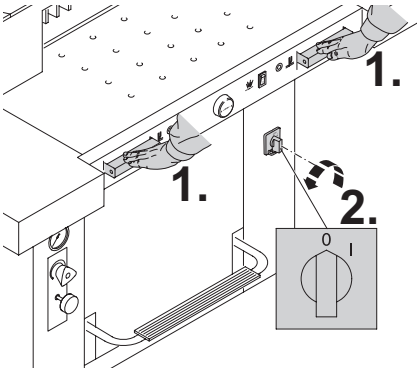

- Activate cutting → blade remains in the lowest position.
- Set main switch to position "0".

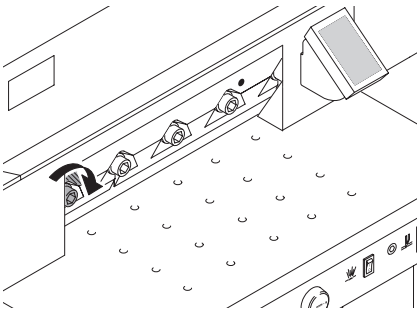

Screw in slightly the left screw.

• Blade and cutting stick replacement •

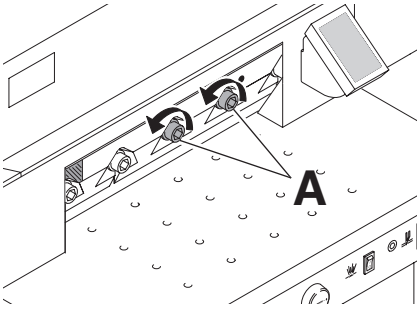

Loosen slightly screws (A) so that the blade slides onto the cutting stick.

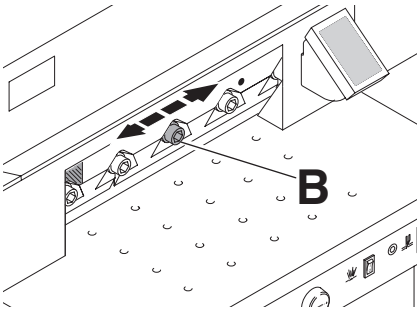

Push the blade and screw (B) as far as possible to the left or right and then centralize them. → The blade must rest on the cutting stick.

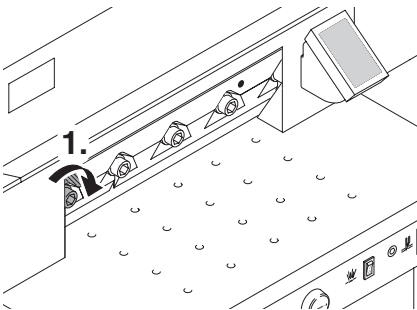

Push in the first screw on the left side and tighten.

IDEAL 5560

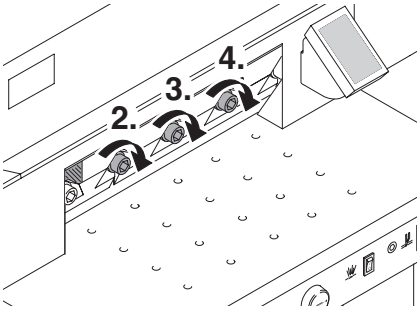

Tighten the remaining 3 screws beginning from the left.

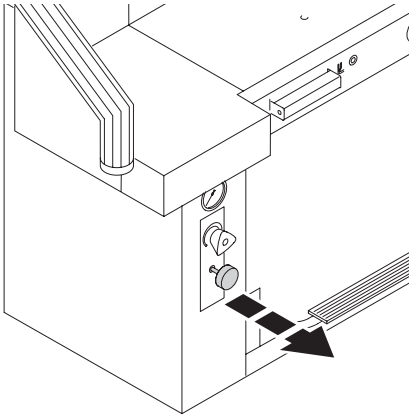

Pull out blade locking key  
→ blade moves to the top.

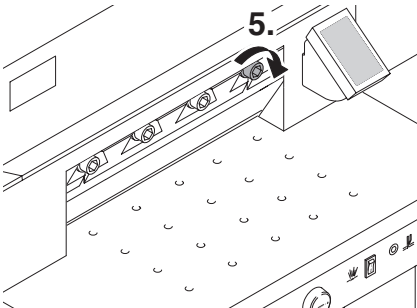

Tighten the screw which is visible at the right.



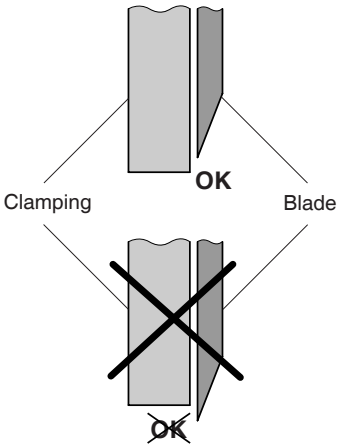

**⚠ Danger!**  
Blade must always be covered by the pressing bar.

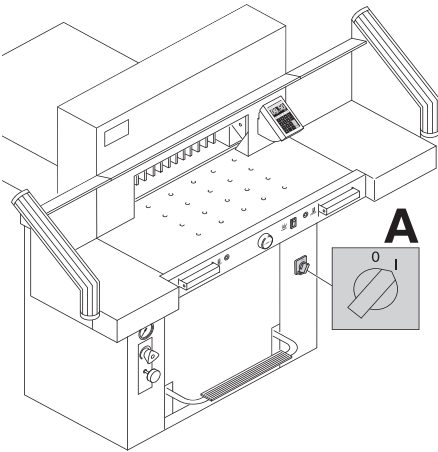

Turn main switch to position "I".

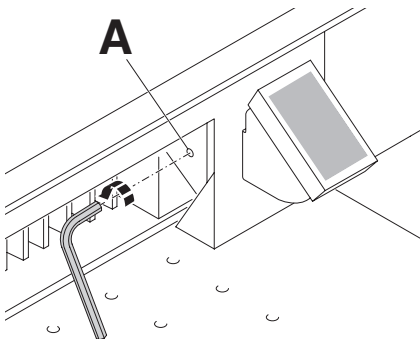

Paper cutting test. If the last sheet or several sheets are not completely cut, gradually turn the knob for blade depth adjustment (**A**) 1/6 turn to the left until the paper is cut along the entire length. Do not set too low as blade will soon become blunt.

## IDEAL 5560

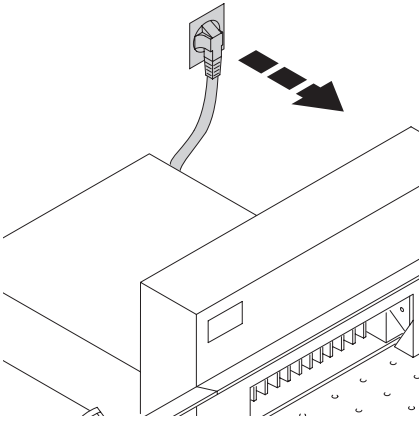

Maintenance work may only be performed by trained staff.

**⚠ Danger!**  
**Disconnect the mains before starting any service work or before removing the cover.**

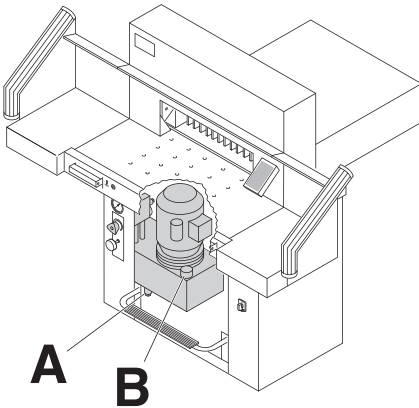

Grease and oil the machine according to the lubrication diagram after 1000 operating hours or once a year. If the machine is subject to excessive load then twice a year.

The hydraulic oil must be changed every 2000 operating hours or every 2 years.

Type of oil:  
Aral Vitam DE 46 to DIN 51562. Volume: approximately 7 litres.

(A) Drain screw  
(B) Oil stick

- Check that the hydraulic pump and screws are not leaking. If necessary tighten the retaining nut.
- Check pressure. Maximum pressure is 150 bar.

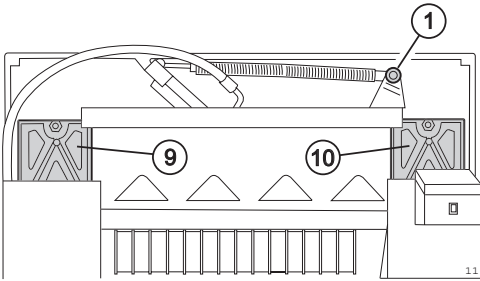

### Lubrication schedule

Lubricate (1) to (8).

Type of oil: SAE10 to SAE50 all types.

Grease (9) to (16)

(9+10) Blade guidance

(11-12) Clamp guidance

Type of grease:

Roller bearing grease - all types.

Oil hinges of the foot clamping device at the front area of the machine room.

Type of oil: SAE10 to SAE50 all types.

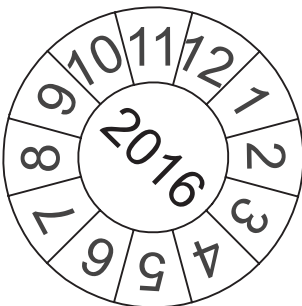
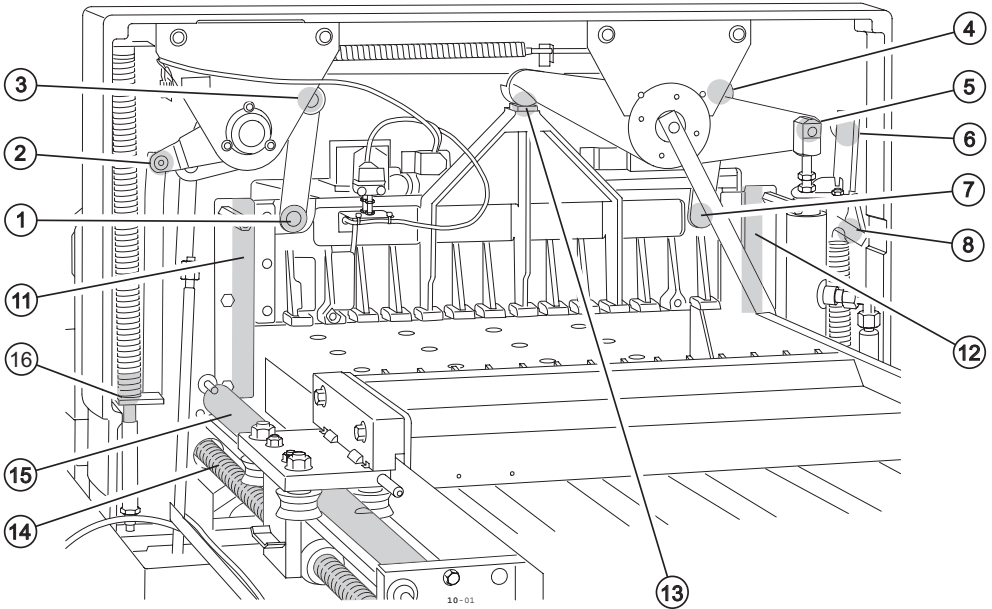

### Safety test

The safety regulations are according to the regulations of the country where the cutting machine is operated. The manufacturer recommends a safety check is made every 5 years by an authorised service team.

IDEAL 5560



**Machine does not function!**

Is the machine plugged in?

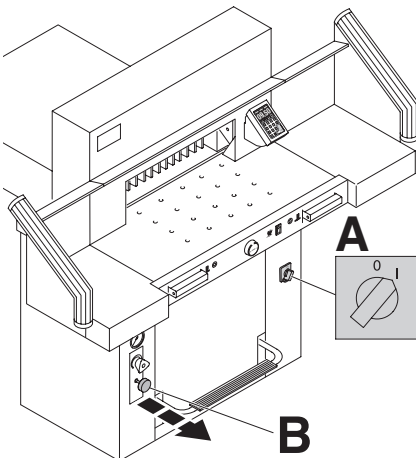
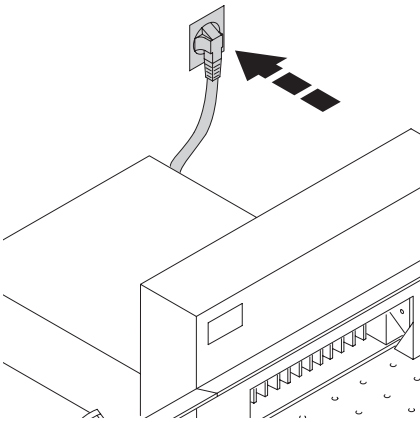

- Main switch to position "I"? (A)
- Blade locking facility (B) must be pulled out.
- Push in the fuses in the back of the machine F1, F2, F3.
- Check the units fuse and the on-site circuit breaker.

• Possible malfunctions •

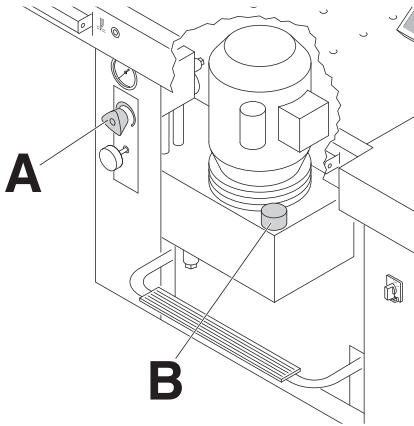

- Oil pressure set too low. → Increase oil pressure at rotary control (A).
- Hydraulic oil shortage. → Check hydraulic oil level (B), if necessary, top up.

## Information

Clamp bar is active, please release clamp

**"Information" Clamp bar is active, please release clamp**

- → Operate the foot pedal (clamping) again.

IDEAL 5560

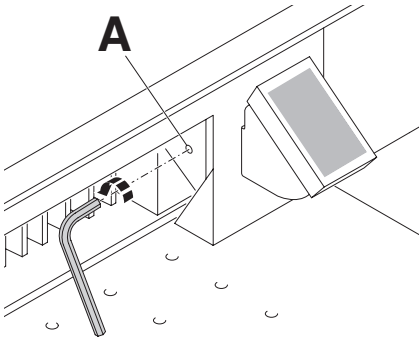

Does not cut through the last sheet.  
→ Reset the cutting depth (**A**) ...

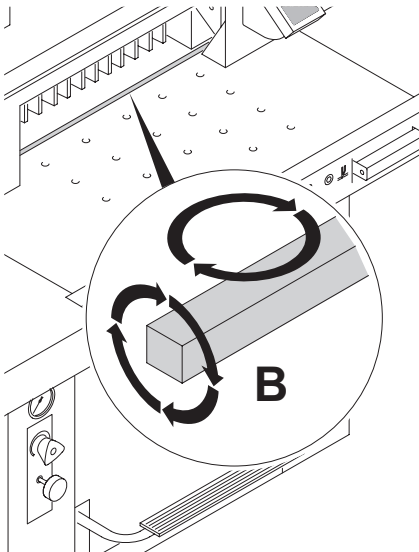

... or turn / replace the cutting stick (**B**). (See page 29 "Blade and cutting stick replacement").

A reduction in the cutting quality indicates that the blade must be sharpened or a blade change is necessary.

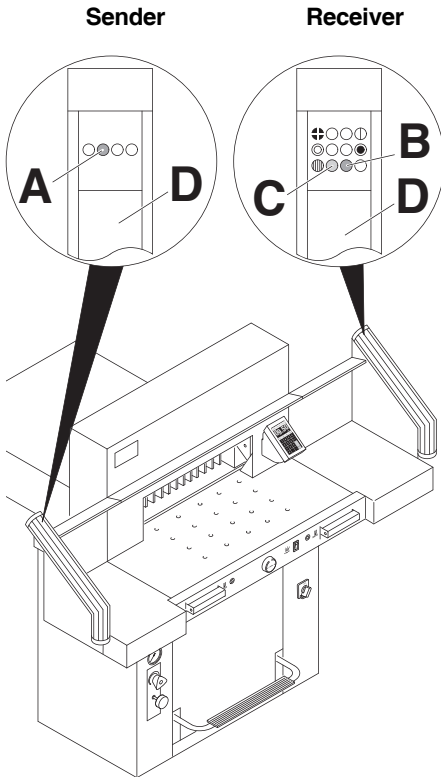

### Trouble shooting-light beam

- During normal operation the LED (A) must illuminate orange and LED (B) green.
- Display (C) is permanently on orange when the sender and/or receiver require cleaning. Clean the glass (D) from the sender and receiver.

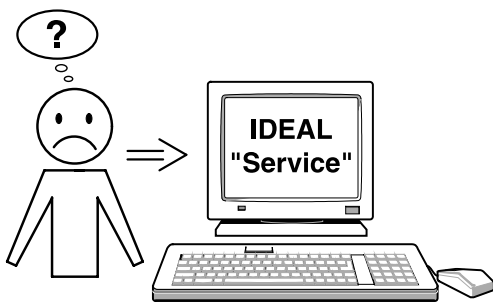

**None of the above mentioned methods helped to solve the problem:**

Contact Service Team under

- [www.ideal.de](http://www.ideal.de) → "Service"  
[service@krug-priester.com](mailto:service@krug-priester.com).

IDEAL 5560

**Recommended accessories:**

**Blade**

- Nr. 3 244 4 015

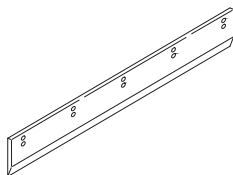

**Cutting stick (6 pieces)**

- Nr. 4 244 1 209

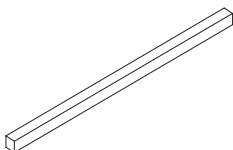

**Blade changing tool <sup>1</sup>**

- Nr. 1206 016

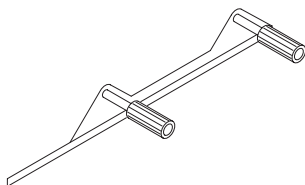

**Paper knock-up block <sup>1</sup>**

- Nr. 9000 521

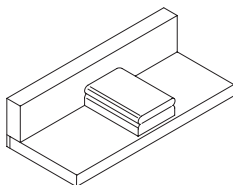

**Side tables left and right**

- Nr. 9000 535

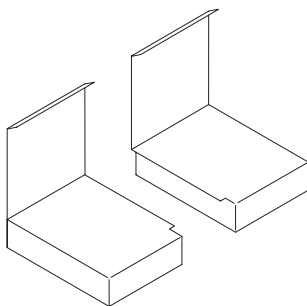

<sup>1</sup> Included in delivery



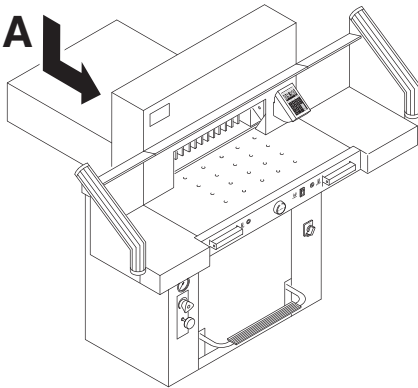

**Technical data:**

Power supply: 230 V / 50 Hz / 8,5A / 1~  
120 V / 60 Hz / 12A / 1~  
Leakage current: < 3,5mA  
Power cord gauge: min. 1,5mm<sup>2</sup> (230V)  
Power cord gauge: AWG 12 (20A) (120V)

Cutting length: 550 mm  
Cutting height: 95 mm  
Table depth: 570 mm  
Sound level EN 13023 : < 70 dB(A)

**Minimum space requirement**

(width x depth x height)  
without side tables (mm): 1070 x 1400 x 1370  
with side tables (mm): 1630 x 1400 x 1370

Clamping pressure: 200 daN bis 1100 daN  
Weight without side tables: 305 kg

Capacity of hydraulic oil: 7 l  
Aral Vitam DE 46 to DIN 51562. Used oil must be disposed of at the authorised place.

Ambient operating temperature: 10 °C - 60 °C  
Air humidity (not condensating): 15 % - 95 %

The exact technical specifications can be found on the technical specifications sticker (A) on the machine. To claim under guarantee, the machine must still carry its original identification label. A wiring diagram is found in the electrical switch box.

**Safety beam guard**

Total reaction time: 100 ms  
Resolution 14 mm/minimum distance: 268 mm  
Resolution 20 mm/minimum distance: 308 mm  
Resolution 30 mm/minimum distance: 388 mm

Subject to alteration without notice.

IDEAL 5560



This machine is approved by independent safety laboratories and is in compliance with the EC-regulations 2006/42/EG and 2004/108/EG.

**Sound level information:**

Sound measurement to EN 13023 :  
72,5 db (A)

Subject to alteration without notice.



I.T.E. Listed 802 D



Krug + Priester has a certified quality management system according to DIN EN ISO 9001:2008 and a certified environmental management system according to DIN ISO 14001:2009.



**D EG-KONFORMITÄTSERKLÄRUNG**  
**GB EC-declaration of conformity**  
**F Déclaration de conformité CE**

- **Hiermit erklären wir, daß die Bauart von**
- Herewith we declare that
- Par la présente, nous déclarons que

**5560**                      **GS ID Nr. 11055101**                      **UL ID Nr. 10055101**

- **folgenden einschlägigen Bestimmungen entspricht**
- complies with the following provisions applying to it
- sont conformes aux dispositions pertinentes suivantes

**2006/42/EG:**

Maschinenrichtline, EC Machinery directive, EC Directives machines.

**2004/108/EG:**

EMV Richtline, EMV Electromagnetic compatibility directive,  
EMV directives compatibilité électromagnétique.

- **Angewendete harmonisierte Normen insbesondere**
- Applied harmonised standards in particular
- Normes harmonisées utilisées, notamment

**EN 60204-1; EN 1010-1; EN 1010-3; EN 55014-1; EN 55014-2;**  
**EN 61000-3-2; EN 61000-3-3; EN ISO 12100; EN 61496-1; EN 61496-2**  
**EN ISO 13857; EN ISO 11204; EN 13023; EN ISO 13849-1**

29.12.2009  
Datum



- Geschäftsführer-

Bevollmächtigter für technische Dokumentation  
Authorized representative for technical documentation  
Représentant autorisé pour la documentation technique

Krug & Priester GmbH u. Co KG  
Simon-Schweitzer-Str. 34  
D-72336 Balingen (Germany)

Remarks:

**IDEAL 5560**

---

Remarks:

Remarks:

• Document Shredders •



• Trimmers and Guillotines •

