

# SCREENFLEX COMMERCIAL EDITION PORTABLE PARTITIONS

## OPERATING INSTRUCTIONS AND PARTS LIST

*Please Read All Instructions Carefully Before Using Partitions*

### FREESTANDING & WALLMOUNTED PARTITIONS OPERATING INSTRUCTIONS

Ready to use, no assembly required. (WALLmounted partitions require wall attachment).

#### To Open

1. Roll FREEstanding Unit to the area where it is to be used. *Leave in a locked position while it is being moved.* (WALLmounted: Pull panels out from wall using the handle).
2. Unlock FREEstanding panels by pulling screenlock handle back and PULLING frame to free panels. *Do not kick the screenlock with your foot. This may cause the screenlock to break.*
3. Pull or push panels to reach desired configuration, by use of the handle and/or by pushing the panels at or below the height of the handle. Nudge each panel into position by gently putting pressure on the back side of the hinge (See illustration). The caster brakes can be used to further secure the location of the unit.

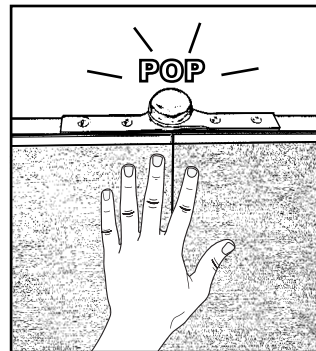
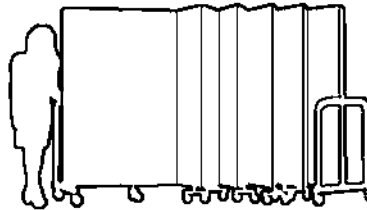
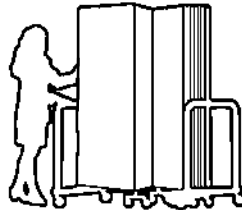
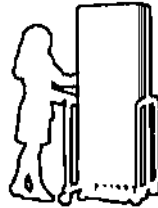

Panels pop into place.

**WARNING - DO NOT** push FREE-standing unit at high speeds over door thresholds or other protrusions in the floor.

*Complete installation instructions are included inside the WALLmount shipping carton. A template is provided for easy and accurate installation.*

Hang Markerboards or pictures on the 1st or 2nd panels closest to each end frame. Do not hang more than 20 lbs. on each side.

**NOTE:** Excessive use of attached items may interfere with the partition's proper operation.

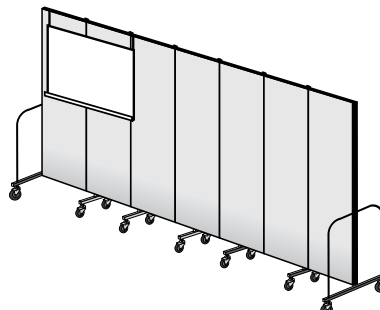

#### To Close

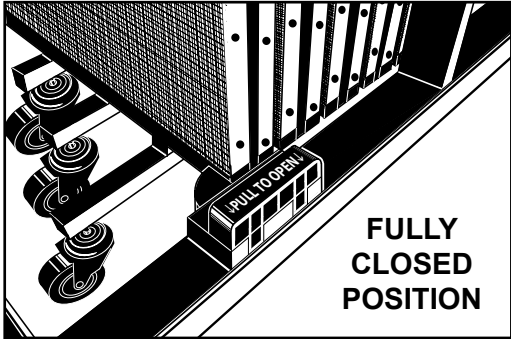
1. Remove all pins, papers and protruding objects from the panels.
  2. Unlock caster brakes and fold all panels back together into stack by folding them against one another.
  3. Fold FREEstanding panels tightly into frame on each side until you hear the click of the screenlock retaining the panels. (Fold WALL-mounted panels snugly against wall).
- 
- FULLY CLOSED POSITION**
4. Roll FREEstanding unit to the next location or to a storage area. **Make sure panels are locked in the closed position before moving.**
  5. Taller units may have straps to wrap around panels before moving.

Please limit movement through low doorways.

**Screenflex**<sup>®</sup>  
PORTABLE PARTITIONS INC.

585 Capital Drive  
Lake Zurich, IL 60047  
800-553-0123

[www.cedividers.com](http://www.cedividers.com)

**SCREENFLEX COMMERCIAL EDITION PARTS LIST**

| KEY NO.            | SF PART NO.    | DESCRIPTION   | PRICE | KEY NO.                       | SF PART NO.    | DESCRIPTION                                    | PRICE |
|--------------------|----------------|---|-------|-------------------------------|----------------|--|-------|
| <b>PANELS</b>      |                |   |       | <b>PLASTIC HARDWARE PARTS</b> |                |  |       |
| 1                  | 3PANEL 42-C,V  | 42" PANEL - COMMERCIAL FABRIC,VINYL                               | 49.00 | 19                            | PL1            | PANELOCK                                       | 19.00 |
| 2                  | 3PANEL 54-C,V  | 54" PANEL - COMMERCIAL FABRIC,VINYL                               | 59.00 | 20                            | 3PCH           | POSITION CONTROLLER (LOCATED ABOVE HINGE)      | 2.90  |
| 3                  | 3PANEL 66-C,V  | 66" PANEL - COMMERCIAL FABRIC,VINYL                               | 72.00 | 21                            | 9PLAS-PLUG-SQ  | 1 1/2" SQUARE BLACK PLASTIC INSERT             | .35   |
| 4                  | 3PANEL74-C,V   | 74" PANEL - COMMERCIAL FABRIC,VINYL                               | 80.00 | 22                            | 9PLAS-PLUG-REC | 3/4" x 1 1/2" RECTANGULAR BLACK PLASTIC INSERT | .35   |
| 5                  | 3PANEL 82-C,V  | 82" PANEL - COMMERCIAL FABRIC,VINYL                               | 88.00 | 23                            | 9PLAS-PLUG-HO  | 5/16" BLACK PLASTIC HOLE PLUG                  | .15   |
| 6                  | 3PANEL 90-C,V  | 90" PANEL - COMMERCIAL FABRIC,VINYL                               | 94.00 | 24                            | 9PLAS-SHANDLE  | STRAP HANDLE                                   | 3.00  |
| <b>METAL PARTS</b> |                |   |       | 25                            | 3PLAS-SLOCK    | SCREENLOCK ASSEMBLY                            | 5.50  |
| 7                  | 9MTH-A         | CHANNEL - PLAIN   | 4.40  | 26                            | 3WM-KIT        | WALLMOUNT INSTALLATION KIT                     | 25.10 |
| 8                  | 9MTH-B         | CHANNEL - SPRING PIN  | 30.45 | 27                            | 9PLAS-PLUG-3/4 | SQUARE PLASTIC INSERT                          | .20   |
| 9A                 | 3MTH-C-BO      | COMPLETE ASSEMBLY - LEG AT END (BLACK FINISH)                     | 22.75 | <b>CABINET PARTS</b>          |                |  |       |
| 9B                 | 3MTH-C-WB-BO   | COMPLETE ASSEMBLY - LEG AT END WITH LOCKING CASTER (BLACK FINISH) | 25.50 | 28                            | 5ROLLBAR-1W    | PLASTIC ROLLER BAR - 1 WHEEL                   | 4.80  |
| 10                 | 3MTH-D-BO      | COMPLETE ASSEMBLY - LEG 3 1/2" FROM END (BLACK FINISH)            | 22.75 | 29                            | 5ROLLBAR-2W    | PLASTIC ROLLER BAR - 2 WHEEL                   | 10.05 |
| 11                 | 3MTH-E-BO      | COMPLETE ASSEMBLY - LEG 7" FROM END (BLACK FINISH)                | 22.75 | 30                            | 5GBAR-R        | GLIDE BAR - UPPER RIGHT SIDE                   | 11.05 |
| 12A                | 3MTH-F-BO      | COMPLETE ASSEMBLY - LEG IN MIDDLE (BLACK FINISH)                  | 22.75 | 31                            | 5GBAR-L        | GLIDE BAR - UPPER LEFT SIDE                    | 11.05 |
| 12B                | 3MTH-FF-BO     | COMPLETE ASSEMBLY - LEG IN MIDDLE, 6'-8" or TALLER (BLACK FINISH) | 23.50 | 32                            | 5GBAR-BOTTOM   | GLIDE BAR - BOTTOM                             | 9.45  |
| 13A                | 9MTH-P         | 4' SIDE CHANNEL   | 10.85 | 33                            | 5LBAR          | LIFT BAR - BOTTOM                              | 6.35  |
| 13B                | 9MTH-O         | 5' SIDE CHANNEL   | 12.10 | 34                            | 5FS-GBINSERT   | GLIDE BAR INSERT                               | .90   |
| 13C                | 9MTH-G         | 6' SIDE CHANNEL   | 13.70 | 35                            | 5TDOOR-HANDLE  | TAMBOUR DOOR HANDLE                            | 7.35  |
| 13E                | 9MTH-J         | 6'8" SIDE CHANNEL   | 14.00 | 36                            | 5TDOOR         | TAMBOUR DOOR (SPECIFY COLOR)                   | 58.10 |
| 13F                | 9MTH-K         | 7'4" SIDE CHANNEL   | 14.15 | 37                            | MBA-D          | DRY ERASE MARKERBOARD - CABINET                | 65.00 |
| 13G                | 9MTH-N         | 8' SIDE CHANNEL   | 15.65 | 39                            | 5CAST-3"       | 3" CASTER W/O BRAKE                            | 8.20  |
| 15A                | 9MTH-FS-GUS    | FREEstanding GUSSETT PLATE LEFT                                   | 6.10  | 40                            | 5CAST-3" RIGID | 3" RIGID CASTER                                | 9.25  |
| 15B                | 9MTH-FS-GUS-R  | FREEstanding GUSSETT PLATE RIGHT                                  | 6.10  | 41                            | 5CAST-3" WB    | 3" LOCKING CASTER                              | 10.50 |
| <b>HINGES</b>      |                |   |       | 42                            | 5CAB-LOCK      | CABINET LOCK SET                               | 15.25 |
| 16A                | 9HINGE-AL42-BO | 42" ALUMINUM CONTINUOUS HINGE-BLACK FINISH                        | 8.55  | 43                            | 5CAB-LOCK-KEY  | CABINET LOCK KEY                               | 3.00  |
| 16B                | 9HINGE-AL54-BO | 54" ALUMINUM CONTINUOUS HINGE-BLACK FINISH                        | 9.70  | <b>OTHER</b>                  |                |  |       |
| 16C                | 9HINGE-AL66-BO | 66" ALUMINUM CONTINUOUS HINGE-BLACK FINISH                        | 10.90 | 44                            | GL             | MULTIUNIT CONNECTOR HARDWARE                   | 50.00 |
| 16D                | 9HINGE-AL74-BO | 74" ALUMINUM CONTINUOUS HINGE-BLACK FINISH                        | 12.10 | 45                            | 9MB-HANGER     | MARKERBOARD HANGING STRAP                      | 10.40 |
| 16E                | 9HINGE-AL82-BO | 82" ALUMINUM CONTINUOUS HINGE-BLACK FINISH                        | 13.70 | 46                            | PSTRAP         | STRAP - PARTITION                              | 4.95  |
| 16F                | 9HINGE-AL90-BO | 90" ALUMINUM CONTINUOUS HINGE-BLACK FINISH                        | 14.55 |                               |                |  |       |
| <b>CASTERS</b>     |                |   |       |                               |                |  |       |
| 17A                | 9CAST-2"-BO    | 2" SOFT RUBBER WHEEL CASTER-BLACK FINISH                          | 2.90  |                               |                |  |       |
| 17B                | 9CAST-2"-WB-BO | 2" SOFT RUBBER LOCKING WHEEL CASTER-BLACK FINISH                  | 3.15  |                               |                |  |       |
| 17C                | 9SPRING-2"     | COMPRESSION SPRING  | .10   |                               |                |  |       |
| 17D                | 9SPRING-2"-T   | COMPRESSION SPRING (7'4", 8'0")                                   | .15   |                               |                |  |       |
| 17E                | 9-FS-3/8-PUSH  | 3/8" PUSHNUT FASTENER   | .25   |                               |                |  |       |
| 18A                | 9CAST-3"-BO    | 3" SOFT RUBBER LOCKING WHEEL CASTER-BLACK FINISH                  | 4.60  |                               |                |  |       |
| 18B                | 9SPRING-3"     | COMPRESSION SPRING  | .20   |                               |                |  |       |
| 18C                | 9FS-ECLIP      | 3/8" RETAINING CLIP   | .10   |                               |                |  |       |

ALL NECESSARY FASTENERS INCLUDED WITH INDIVIDUAL PARTS

*To order parts please contact Screenflex Customer Service Department.  
1-800-553-0123      customerservice@screenflex.com*

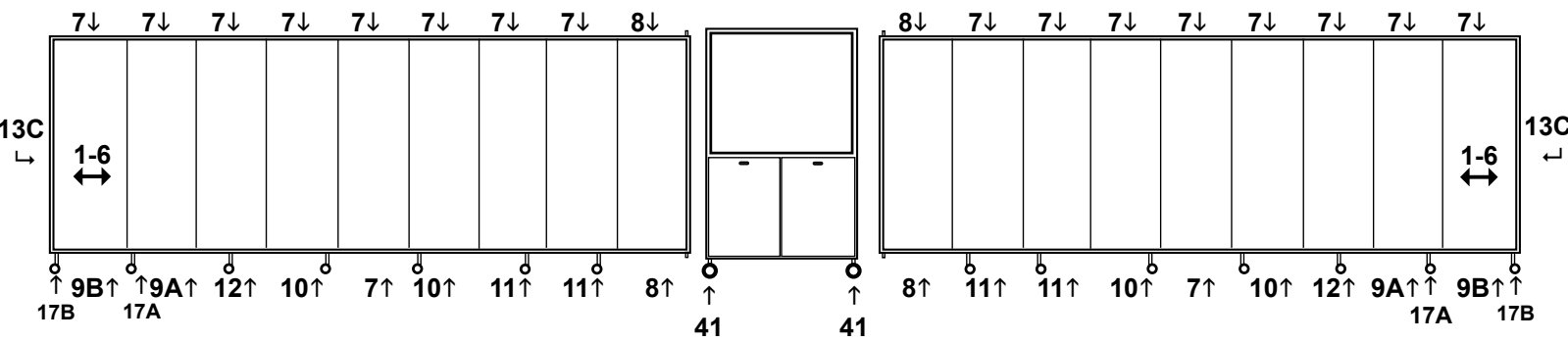

**Figure #1 - Screenflex Portable Classrooms**

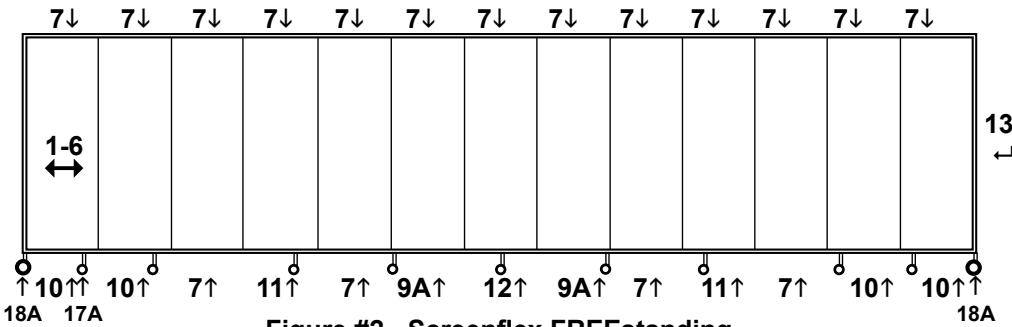

**Figure #2 - Screenflex FREEstanding  
(24'-1" / 13 panel unit shown)**

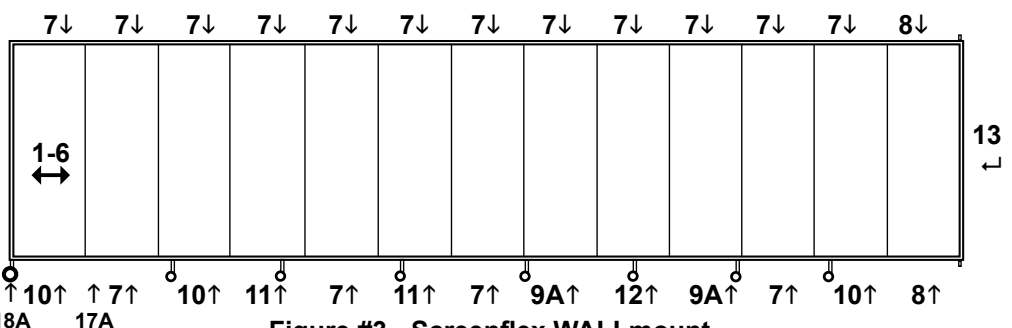

**Figure #3 - Screenflex WALLmount  
(23'-10" / 13 panel unit shown)**

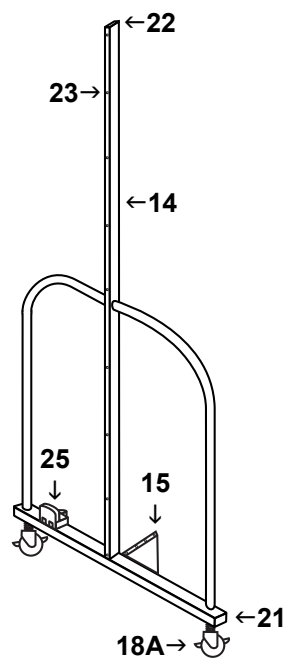

**Figure #4 - FREEstanding  
End Frame**

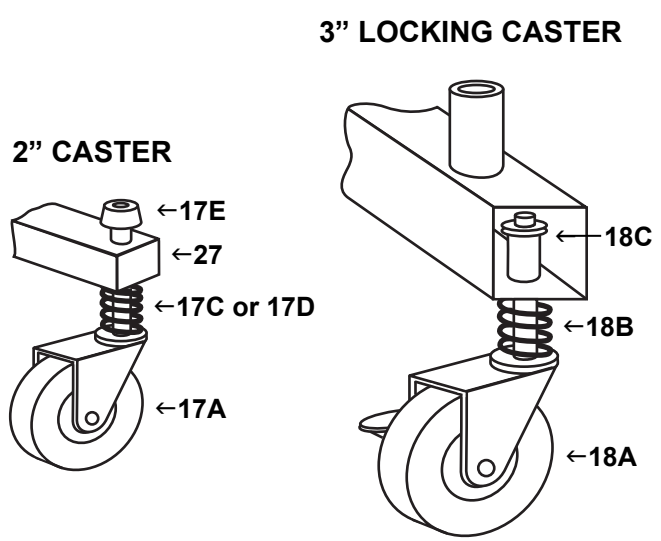

**Figure #5 - Self-Leveling Caster Components**

## COMMERCIAL EDITION SCREENFLEX LIMITED WARRANTY

Thank you for your purchase of Screenflex Portable Partitions. We are confident that you will appreciate the fine quality and craftsmanship of our products. We at Screenflex stand behind the products we manufacture and provide you with a Lifetime limited warranty. We appreciate your business and look forward to being of service to you in the future.

Please thoroughly inspect your partitions after opening the carton(s). If you have any questions or comments about the condition of the partitions, please call Customer Service at 800-553-0123.

Screenflex Portable Partitions Inc Warrants its product to the original purchaser to be free from defects in workmanship and material for the life of the product. This limited warranty does not cover wear from ordinary use, improper storage or installation, abuse, neglect or damage beyond the control of Screenflex. Screenflex's obligation under this warranty shall be limited to the repair or exchange of any part which proves defective. Screenflex makes no other warranty expressed or implied, as to any matter whatsoever, including the product's condition, its merchantability, or its fitness for any particular use or purpose. Under no circumstances shall Screenflex be liable for incidental or consequential damages. Screenflex reserves the right to modify design, specifications, and other materials without prior notice.

# COMMERCIAL EDITION PORTABLE CLASSROOM OPERATING INSTRUCTIONS

## To Open

1. Roll Screenflex cabinet to the area where it will be used. Before final placement, push/pull unit from side to side to expose two caster brake pedals.
2. Lock the cabinet casters which are exposed from the base. To secure cabinet it is only necessary that two of the four casters are locked.
3. Using two hands, pull up both tambour doors on each side using the handles located near the base. This will expose the dividers.
4. Pull out both dividers using the handle located in the edge of the lead panel.
5. Push/pull panels to reach desired configuration of the divider by use of the handle, and by pushing the panels at or below the height of the handle.
6. Optional - Place Panelclips (contained in Panelclip storage bag) on the top of the hinge joints between the divider panels.

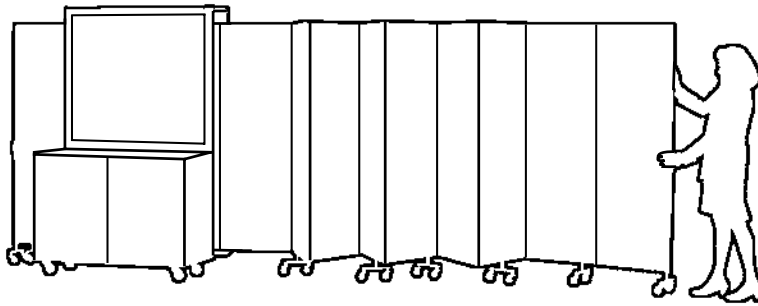
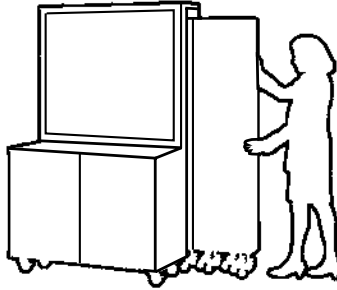
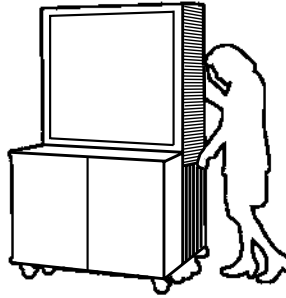

## To Close

1. Remove Panelclips from the panels and place back into storage bag. Remove all pins, papers and protruding objects from the panels.
2. Fold all divider panels back together into stack by pushing and folding them against one another. Push low on the panels at or below the height of the handle.
3. Push folded dividers back into the cabinet until they stop.
4. Make sure that the dividers clear tambour door track. This will enable the tambour door to close freely. A good firm push is recommended to make sure the panel set is properly located in the storage compartment.
5. Using two hands, control and guide the tambour door down into the closed position by pulling down the handle. **Do not let the tambour door slam closed.**
6. Unlock cabinet casters by pulling up on the pedals and roll Screenflex to the next location or a storage area.

WARNING - DO NOT transport cabinet to another facility without first detaching and removing the dividers from the cabinet. DO NOT push cabinet at high speeds over door thresholds or other protrusions in the floor.

Folding Partition Mounting Hardware

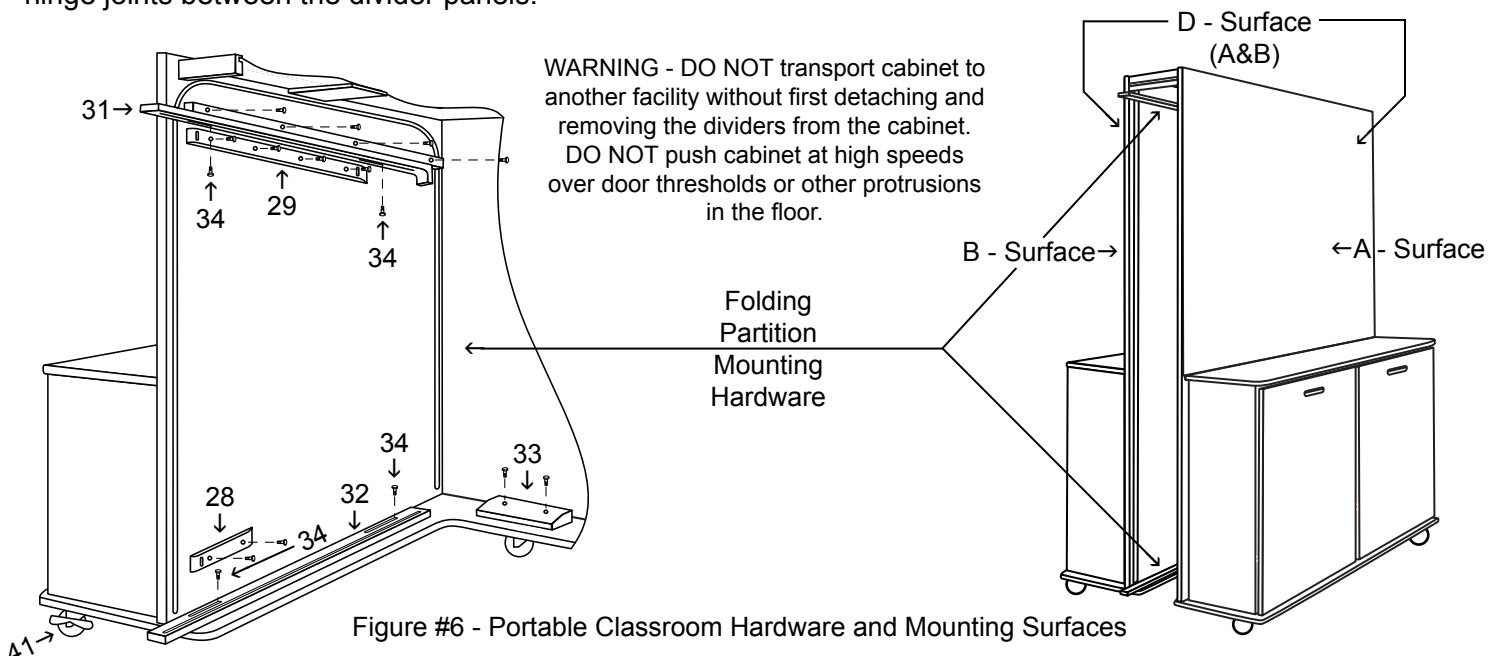

Figure #6 - Portable Classroom Hardware and Mounting Surfaces