

LasscoJog™ LJ-4 Paper Jogger

USERS MANUAL



Before operating this equipment, please read these instructions completely and keep these operating instructions for future reference.

Serial Number: _____
Date of Purchase: _____
Dealer: _____
Address: _____

Telephone Number: _____

Lassco  Wizer

485 Hague Street, Rochester, NY 14606 U.S.A.
Tel: 585-436-1934 Fax: 585-464-8665
www.lasscowizer.com info@lasscowizer.com

Instructions

Loose Item Inventory

■ Please remove and inspect the following items.

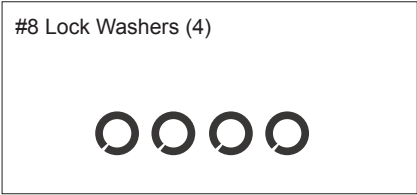
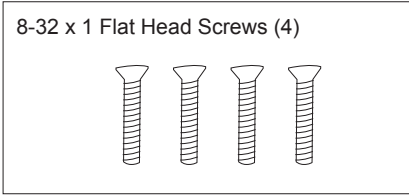
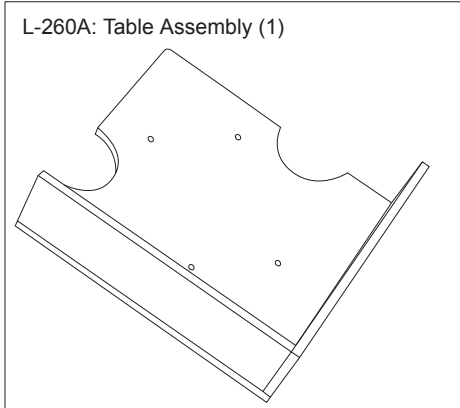

Setting Up Your Machine

■ Attach the Table (L-260A) to the Table Support using four (4) 8-32 x 1 Flat Head Screws, eight (8) 8-32 Stop Nuts, and four (4) #8 Lock Washers.

- Step #1** Insert the four (4) Flat Head Screws through the front of the Table as shown.
- Step #2** Place the Flat Head Screws through the holes of the Table Support.
- Step #3** Attach the first Stop Nut and tighten.
- Step #4** Place a Lock Washer over the screw.
- Step #5** Attach the second Stop Nut and tighten.
- Step #6** Repeat steps 3 - 5 on the remaining screws.

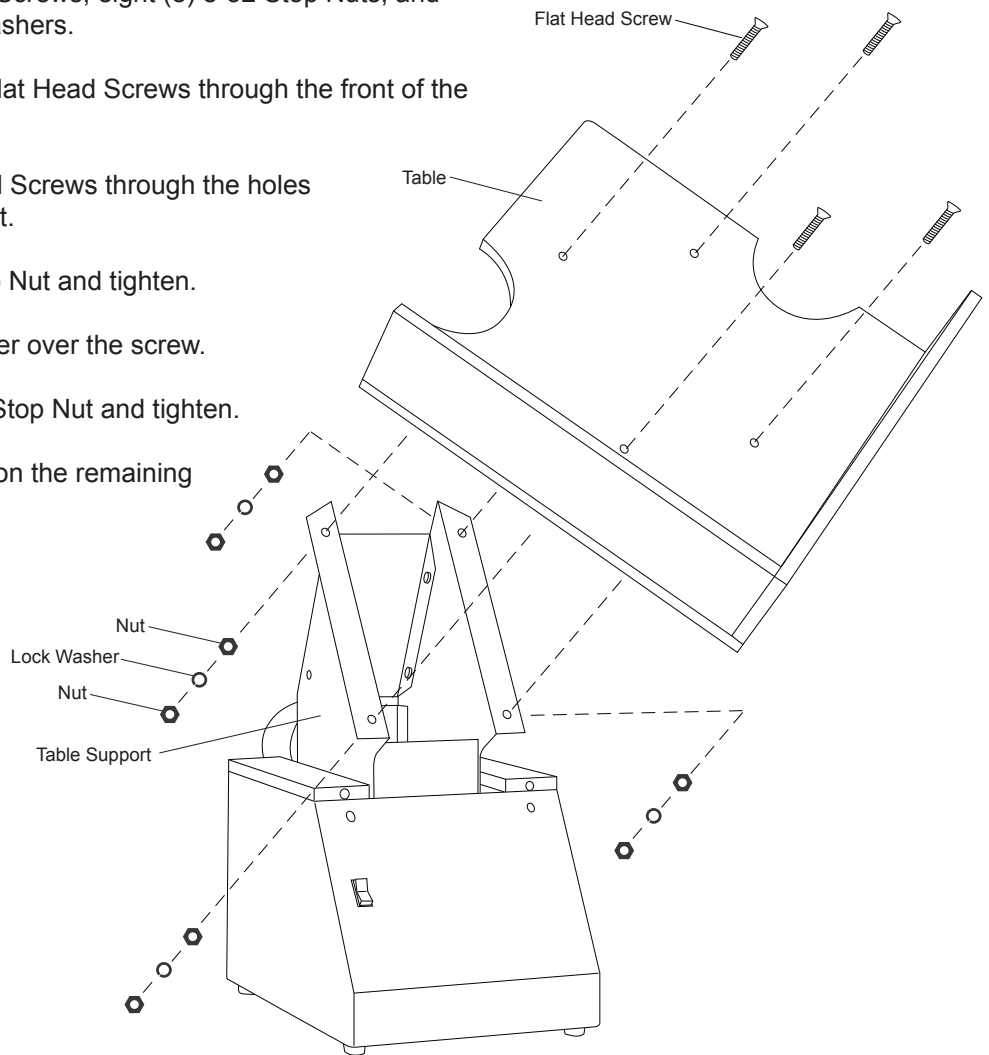

Instructions

Adjusting the Jogging Speed

■ To change the Jogging action:

Step #1 Open the back panel on the rear of the machine by removing the two bottom screws and flipping the cover up as shown in the rear view.

Step #2 Loosen the Button Head Machine Screw (7) and rotate one of the Adjustment Discs (6) attached to the Disc Shaft (8) extending from the motor (1).

Step #3 Tighten down the Machine Screw.

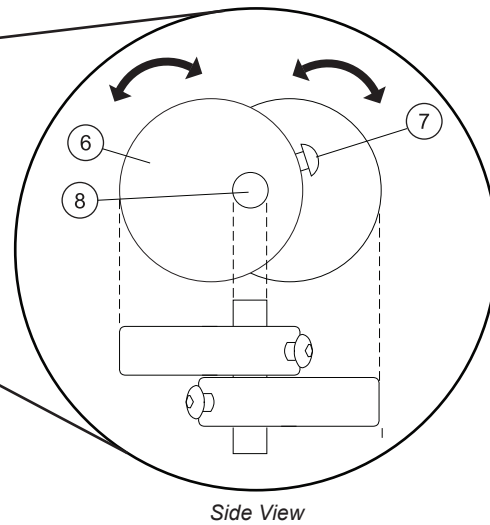
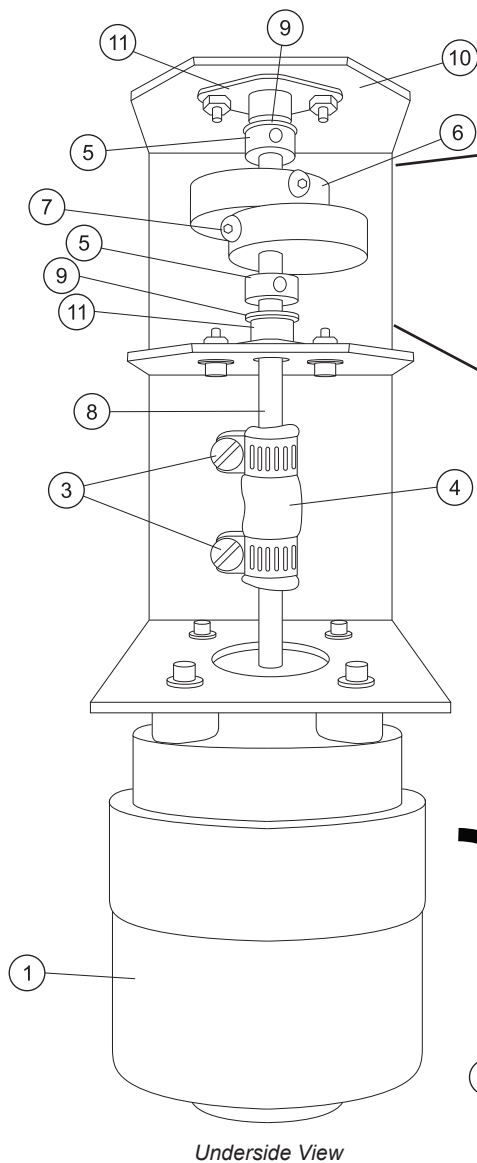
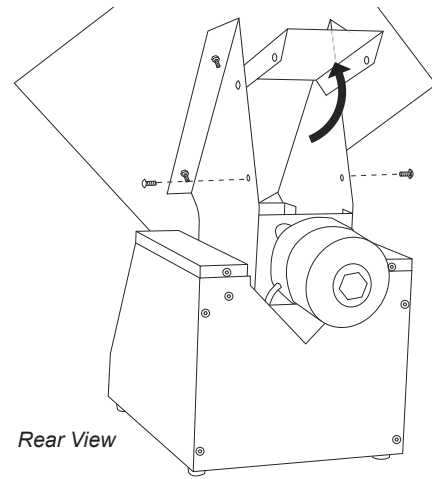

- ① L-1014: Motor
- ② FM5-5008: Electric Cord
- ③ L-1020: #6 Hose Clamp
- ④ L-1019: Torque Tube
- ⑤ L-1021: Shaft Collar
- ⑥ L-1017: Eccentric Adjustment Disc
- ⑦ 10-32 Screw x 3/4 Button Head Machine Screw
- ⑧ L-1018: Eccentric Disc Shaft
- ⑨ 3/8" ID x 3/4" OD Fiber Washer
- ⑩ L-1016: Clevis
- ⑪ L-1034: Flange Bearing

Note: When the screws are located opposite each other on the shaft, the minimum action is obtained. When the screws are located on the same side of the shaft, the maximum action is obtained. Normal action is obtained when the screws are 80° to 90° apart.

Trouble Shooting Guide

Problem	Cause	Correction
Machine does not turn on.	Machine is not plugged in or there is no electricity to the outlet.	Make sure the power cord is connected correctly and that the outlet is live.
	Power switch is faulty.	Contact a service technician to replace the power switch.
	Motor has burned out.	Contact a service technician to replace the motor.
The motor turns on but the machine does not jog as desired.	The Torque Tube (L-1019) has worn out or broken.	Replace the Torque Tube.
	The screw on the Eccentric Adjustment Disc (L-1017) has come loose allowing the disc to shift.	Access the Adjustment Discs and tighten down the screw as shown on page 1.