

SCREENFLEX COMMERCIAL EDITION PORTABLE PARTITIONS

OPERATING INSTRUCTIONS AND PARTS LIST

Please Read All Instructions Carefully Before Using Partitions

FREESTANDING & WALLMOUNTED PARTITIONS OPERATING INSTRUCTIONS

Ready to use, no assembly required. (WALLmounted partitions require wall attachment).

To Open

1. Roll FREEstanding Unit to the area where it is to be used. *Leave in a locked position while it is being moved.* (WALLmounted: Pull panels out from wall using the handle).
2. Unlock FREEstanding panels by pulling screenlock handle back and PULLING frame to free panels. *Do not kick the screenlock with your foot. This may cause the screenlock to break.*
3. Pull or push panels to reach desired configuration, by use of the handle and/or by pushing the panels at or below the height of the handle. Nudge each panel into position by gently putting pressure on the back side of the hinge (See illustration). The caster brakes can be used to further secure the location of the unit.

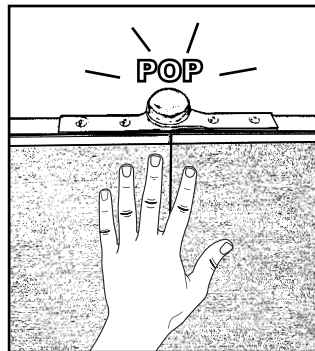
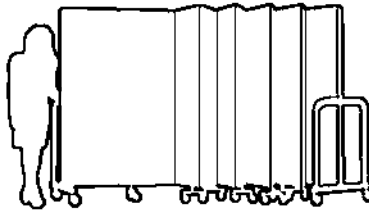
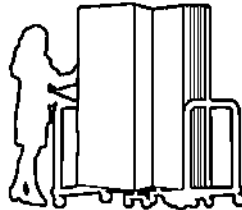
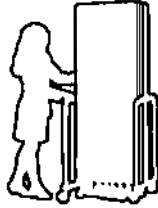

Panels pop into place.

WARNING - DO NOT push FREE-standing unit at high speeds over door thresholds or other protrusions in the floor.

Complete installation instructions are included inside the WALLmount shipping carton. A template is provided for easy and accurate installation.

Hang Markerboards or pictures on the 1st or 2nd panels closest to each end frame. Do not hang more than 20 lbs. on each side.

NOTE: Excessive use of attached items may interfere with the partition's proper operation.

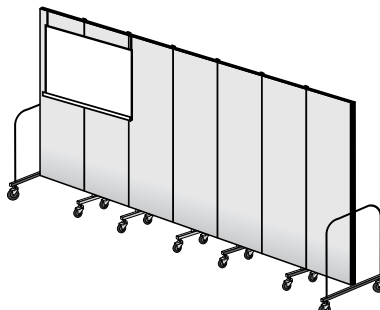

To Close

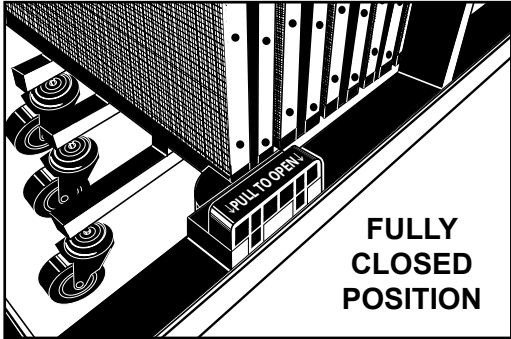
1. Remove all pins, papers and protruding objects from the panels.
 2. Unlock caster brakes and fold all panels back together into stack by folding them against one another.
 3. Fold FREEstanding panels tightly into frame on each side until you hear the click of the screenlock retaining the panels. (Fold WALL-mounted panels snugly against wall).
- 
4. Roll FREEstanding unit to the next location or to a storage area. **Make sure panels are locked in the closed position before moving.**
 5. Taller units may have straps to wrap around panels before moving.

Please limit movement through low doorways.

Screenflex[®]
PORTABLE PARTITIONS INC.

585 Capital Drive
Lake Zurich, IL 60047
800-553-0123

www.cedividers.com

SCREENFLEX COMMERCIAL EDITION PARTS LIST

KEY NO.	SF PART NO.	DESCRIPTION	PRICE	KEY NO.	SF PART NO.	DESCRIPTION	PRICE
PANELS				PLASTIC HARDWARE PARTS			
1	3PANEL 42-C,V	42" PANEL - COMMERCIAL FABRIC,VINYL	49.00	19	PL1	PANELOCK	19.00
2	3PANEL 54-C,V	54" PANEL - COMMERCIAL FABRIC,VINYL	59.00	20	3PCH	POSITION CONTROLLER (LOCATED ABOVE HINGE)	2.90
3	3PANEL 66-C,V	66" PANEL - COMMERCIAL FABRIC,VINYL	72.00	21	9PLAS-PLUG-SQ	1 1/2" SQUARE BLACK PLASTIC INSERT	.35
4	3PANEL74-C,V	74" PANEL - COMMERCIAL FABRIC,VINYL	80.00	22	9PLAS-PLUG-REC	3/4" x 1 1/2" RECTANGULAR BLACK PLASTIC INSERT	.35
5	3PANEL 82-C,V	82" PANEL - COMMERCIAL FABRIC,VINYL	88.00	23	9PLAS-PLUG-HO	5/16" BLACK PLASTIC HOLE PLUG	.15
6	3PANEL 90-C,V	90" PANEL - COMMERCIAL FABRIC,VINYL	94.00	24	9PLAS-SHANDLE	STRAP HANDLE	3.00
METAL PARTS				25	3PLAS-SLOCK	SCREENLOCK ASSEMBLY	5.50
7	9MTH-A	CHANNEL - PLAIN	4.40	26	3WM-KIT	WALLMOUNT INSTALLATION KIT	25.10
8	9MTH-B	CHANNEL - SPRING PIN	30.45	27	9PLAS-PLUG-3/4	SQUARE PLASTIC INSERT	.20
9A	3MTH-C-BO	COMPLETE ASSEMBLY - LEG AT END (BLACK FINISH)	22.75	CABINET PARTS			
9B	3MTH-C-WB-BO	COMPLETE ASSEMBLY - LEG AT END WITH LOCKING CASTER (BLACK FINISH)	25.50	28	5ROLLBAR-1W	PLASTIC ROLLER BAR - 1 WHEEL	4.80
10	3MTH-D-BO	COMPLETE ASSEMBLY - LEG 3 1/2" FROM END (BLACK FINISH)	22.75	29	5ROLLBAR-2W	PLASTIC ROLLER BAR - 2 WHEEL	10.05
11	3MTH-E-BO	COMPLETE ASSEMBLY - LEG 7" FROM END (BLACK FINISH)	22.75	30	5GBAR-R	GLIDE BAR - UPPER RIGHT SIDE	11.05
12A	3MTH-F-BO	COMPLETE ASSEMBLY - LEG IN MIDDLE (BLACK FINISH)	22.75	31	5GBAR-L	GLIDE BAR - UPPER LEFT SIDE	11.05
12B	3MTH-FF-BO	COMPLETE ASSEMBLY - LEG IN MIDDLE, 6'-8" or TALLER (BLACK FINISH)	23.50	32	5GBAR-BOTTOM	GLIDE BAR - BOTTOM	9.45
13A	9MTH-P	4' SIDE CHANNEL	10.85	33	5LBAR	LIFT BAR - BOTTOM	6.35
13B	9MTH-O	5' SIDE CHANNEL	12.10	34	5FS-GBINSERT	GLIDE BAR INSERT	.90
13C	9MTH-G	6' SIDE CHANNEL	13.70	35	5TDOOR-HANDLE	TAMBOUR DOOR HANDLE	7.35
13E	9MTH-J	6'8" SIDE CHANNEL	14.00	36	5TDOOR	TAMBOUR DOOR (SPECIFY COLOR)	58.10
13F	9MTH-K	7'4" SIDE CHANNEL	14.15	37	MBA-D	DRY ERASE MARKERBOARD - CABINET	65.00
13G	9MTH-N	8' SIDE CHANNEL	15.65	39	5CAST-3"	3" CASTER W/O BRAKE	8.20
15A	9MTH-FS-GUS	FREEstanding GUSSETT PLATE LEFT	6.10	40	5CAST-3" RIGID	3" RIGID CASTER	9.25
15B	9MTH-FS-GUS-R	FREEstanding GUSSETT PLATE RIGHT	6.10	41	5CAST-3" WB	3" LOCKING CASTER	10.50
HINGES				42	5CAB-LOCK	CABINET LOCK SET	15.25
16A	9HINGE-AL42-BO	42" ALUMINUM CONTINUOUS HINGE-BLACK FINISH	8.55	43	5CAB-LOCK-KEY	CABINET LOCK KEY	3.00
16B	9HINGE-AL54-BO	54" ALUMINUM CONTINUOUS HINGE-BLACK FINISH	9.70	OTHER			
16C	9HINGE-AL66-BO	66" ALUMINUM CONTINUOUS HINGE-BLACK FINISH	10.90	44	GL	MULTIUNIT CONNECTOR HARDWARE	50.00
16D	9HINGE-AL74-BO	74" ALUMINUM CONTINUOUS HINGE-BLACK FINISH	12.10	45	9MB-HANGER	MARKERBOARD HANGING STRAP	10.40
16E	9HINGE-AL82-BO	82" ALUMINUM CONTINUOUS HINGE-BLACK FINISH	13.70	46	PSTRAP	STRAP - PARTITION	4.95
16F	9HINGE-AL90-BO	90" ALUMINUM CONTINUOUS HINGE-BLACK FINISH	14.55				
CASTERS							
17A	9CAST-2"-BO	2" SOFT RUBBER WHEEL CASTER-BLACK FINISH	2.90				
17B	9CAST-2"-WB-BO	2" SOFT RUBBER LOCKING WHEEL CASTER-BLACK FINISH	3.15				
17C	9SPRING-2"	COMPRESSION SPRING	.10				
17D	9SPRING-2"-T	COMPRESSION SPRING (7'4", 8'0")	.15				
17E	9-FS-3/8-PUSH	3/8" PUSHNUT FASTENER	.25				
18A	9CAST-3"-BO	3" SOFT RUBBER LOCKING WHEEL CASTER-BLACK FINISH	4.60				
18B	9SPRING-3"	COMPRESSION SPRING	.20				
18C	9FS-ECLIP	3/8" RETAINING CLIP	.10				

ALL NECESSARY FASTENERS INCLUDED WITH INDIVIDUAL PARTS

*To order parts please contact Screenflex Customer Service Department.
1-800-553-0123 customerservice@screenflex.com*

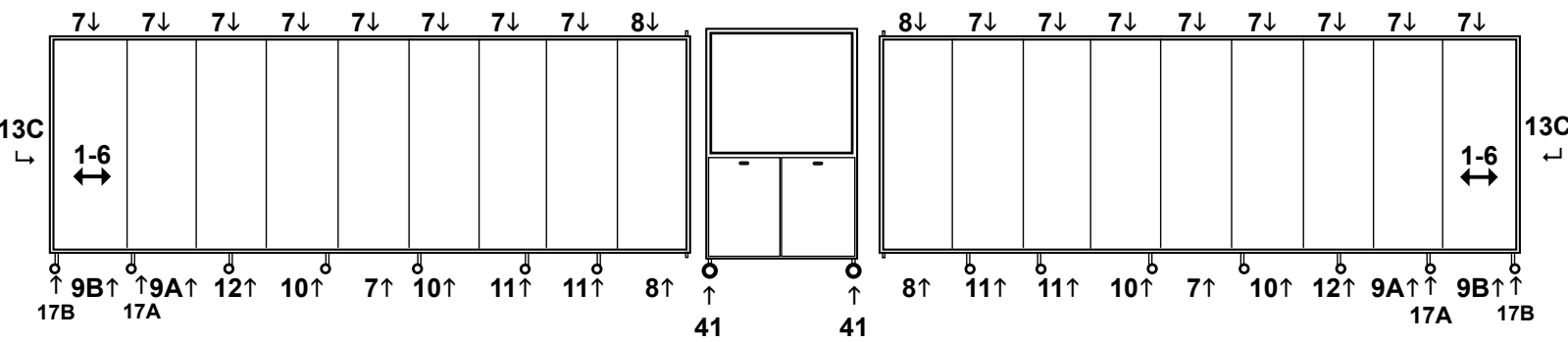
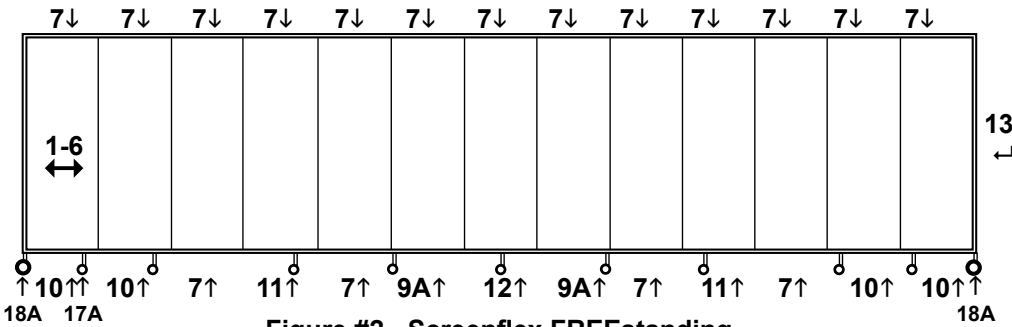
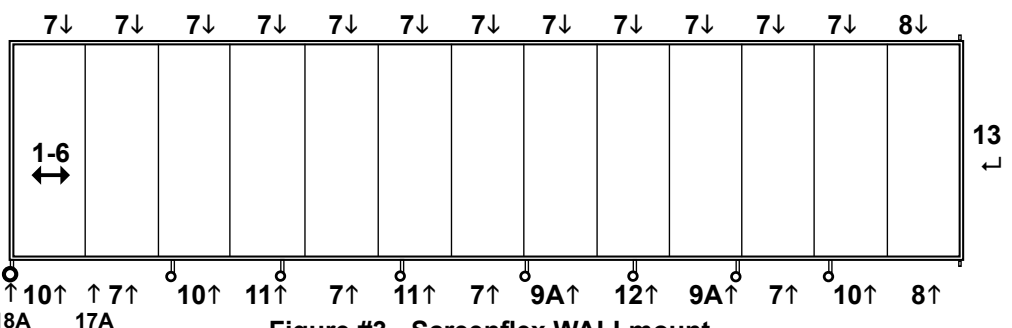

Figure #1 - Screenflex Portable Classrooms



**Figure #2 - Screenflex FREEstanding
(24'-1" / 13 panel unit shown)**



**Figure #3 - Screenflex WALLmount
(23'-10" / 13 panel unit shown)**

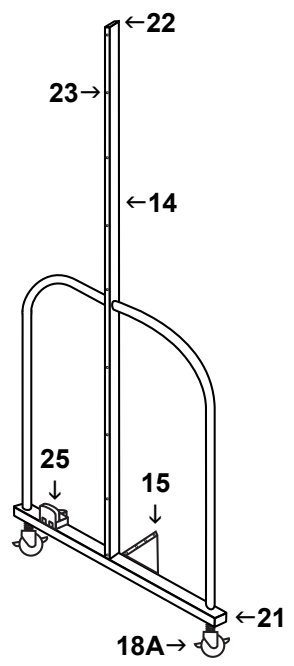

Figure #4 - FREEstanding End Frame

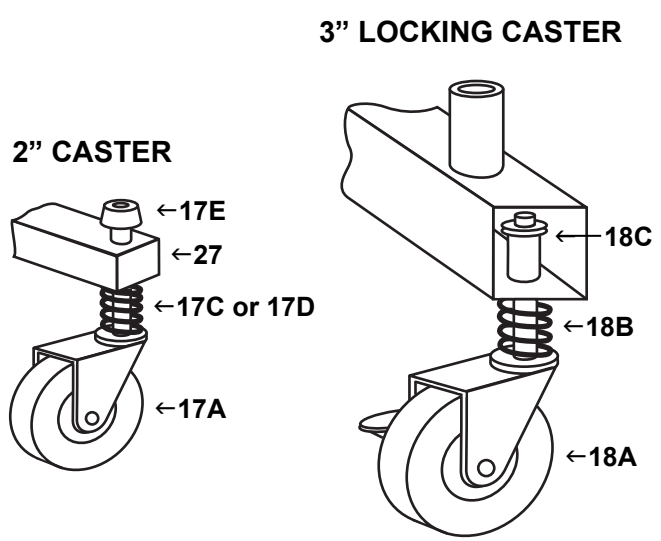

Figure #5 - Self-Leveling Caster Components

COMMERCIAL EDITION SCREENFLEX LIMITED WARRANTY

Thank you for your purchase of Screenflex Portable Partitions. We are confident that you will appreciate the fine quality and craftsmanship of our products. We at Screenflex stand behind the products we manufacture and provide you with a Lifetime limited warranty. We appreciate your business and look forward to being of service to you in the future.

Please thoroughly inspect your partitions after opening the carton(s). If you have any questions or comments about the condition of the partitions, please call Customer Service at 800-553-0123.

Screenflex Portable Partitions Inc Warrants its product to the original purchaser to be free from defects in workmanship and material for the life of the product. This limited warranty does not cover wear from ordinary use, improper storage or installation, abuse, neglect or damage beyond the control of Screenflex. Screenflex's obligation under this warranty shall be limited to the repair or exchange of any part which proves defective. Screenflex makes no other warranty expressed or implied, as to any matter whatsoever, including the product's condition, its merchantability, or its fitness for any particular use or purpose. Under no circumstances shall Screenflex be liable for incidental or consequential damages. Screenflex reserves the right to modify design, specifications, and other materials without prior notice.

COMMERCIAL EDITION PORTABLE CLASSROOM OPERATING INSTRUCTIONS

To Open

1. Roll Screenflex cabinet to the area where it will be used. Before final placement, push/pull unit from side to side to expose two caster brake pedals.
2. Lock the cabinet casters which are exposed from the base. To secure cabinet it is only necessary that two of the four casters are locked.
3. Using two hands, pull up both tambour doors on each side using the handles located near the base. This will expose the dividers.
4. Pull out both dividers using the handle located in the edge of the lead panel.
5. Push/pull panels to reach desired configuration of the divider by use of the handle, and by pushing the panels at or below the height of the handle.
6. Optional - Place Panelclips (contained in Panelclip storage bag) on the top of the hinge joints between the divider panels.

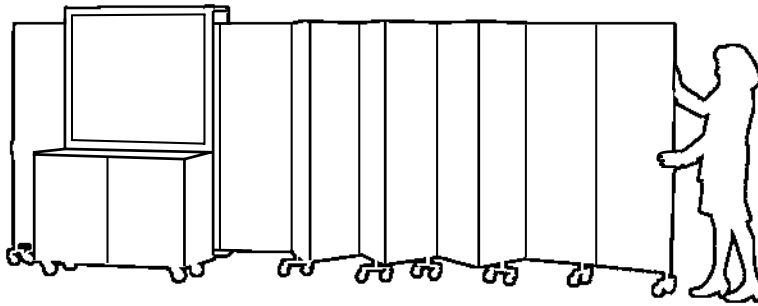
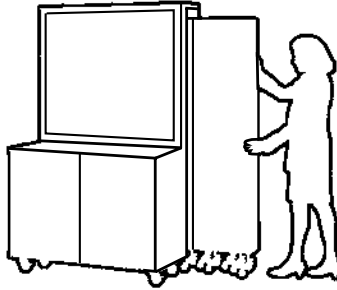
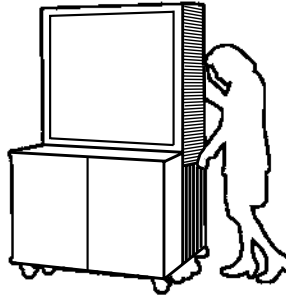

To Close

1. Remove Panelclips from the panels and place back into storage bag. Remove all pins, papers and protruding objects from the panels.
2. Fold all divider panels back together into stack by pushing and folding them against one another. Push low on the panels at or below the height of the handle.
3. Push folded dividers back into the cabinet until they stop.
4. Make sure that the dividers clear tambour door track. This will enable the tambour door to close freely. A good firm push is recommended to make sure the panel set is properly located in the storage compartment.
5. Using two hands, control and guide the tambour door down into the closed position by pulling down the handle. **Do not let the tambour door slam closed.**
6. Unlock cabinet casters by pulling up on the pedals and roll Screenflex to the next location or a storage area.

ProSource Packaging, Inc.
14911 Stuebner Airline Suite A
Houston, TX 77069
800-203-0233
www.Machine-Solution.com

WARNING - DO NOT transport cabinet to another facility without first detaching and removing the dividers from the cabinet. DO NOT push cabinet at high speeds over door thresholds or other protrusions in the floor.

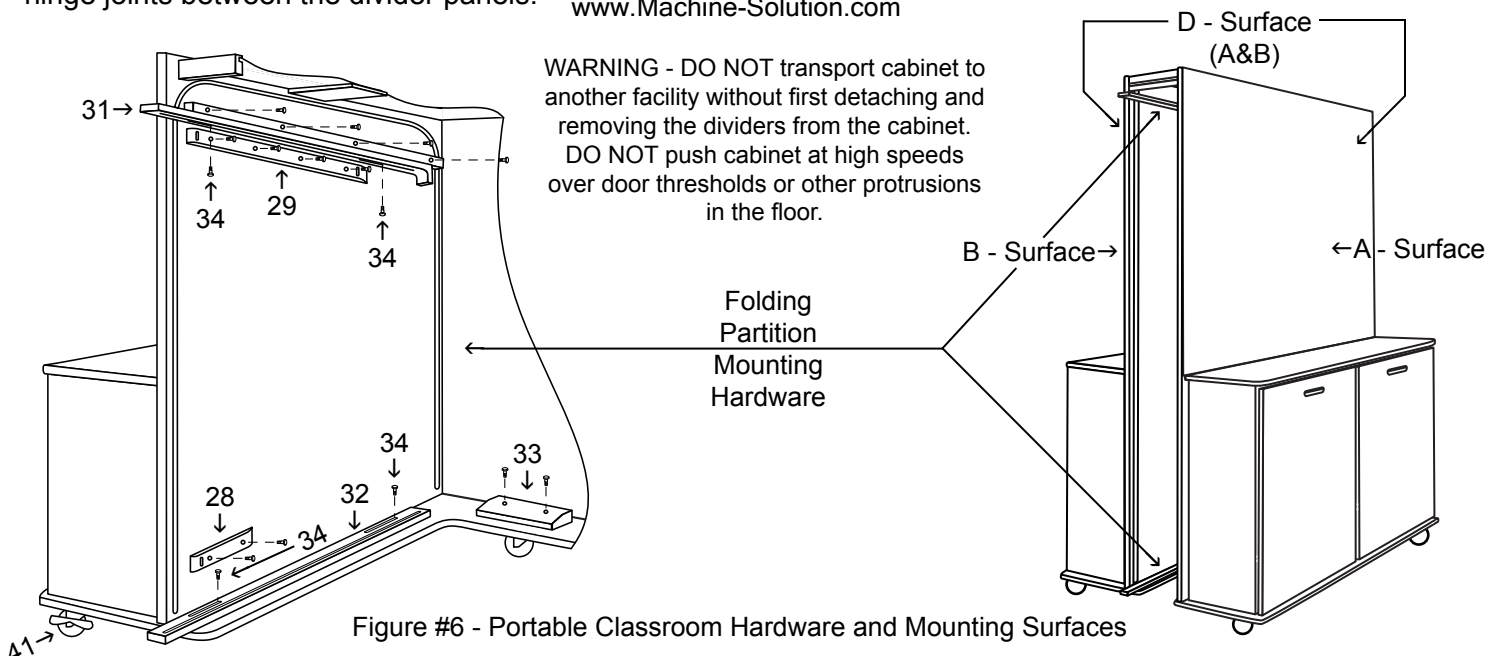

Figure #6 - Portable Classroom Hardware and Mounting Surfaces