

ProSource Packaging, Inc.
 14911 Stuebner Airline Suite A
 Houston, TX 77069
 800-203-0233
 www.Machine-Solution.com

PARTS LIST & DIAGRAM

Part No.	Description	Qty	
1	W-O008572	Base	1
2	W-O008607	L.S. Extrusion	1
3	M-S045039	L.C.D. Counter	1
4	W-O008649	LS Bottom Trim	1
5	W-O008573	End Cover	2
6	W-O008616	Top/Signature Shaft	1
7	W-O008730	Interlock Sw. Block	1
8	M-O008729	LH Ink Roller Sup Block	1
9	M-S013001	Tractor Shaft Bushing	2
10	M-O008623	Cover Stop	2
11	M-S001077	6-32X1/4 Phil Flat Head	2
12	M-S033038	Hood Interlock Switch	1
13	M-S019021	3/4" Set Collar	2
14	W-O008601	Left Side Main Frame	1
15	W-O008735	B/O LS Hood Bracket	1
16	M-S013039	Print Shaft Bushing	4
17	M-S005001	Ink Roller Thumb Screw	1
18	WRA008530	Black Ink Roller Asm.	1
19	WRA008575	3 Color Ink Roller Asm.	1
20	W-O008652	Ink Roller Shaft	1
21	M-O008728	RH Ink Roller Sup Block	1
22	W-A008610	Hood Assembly	1
23	M-O008613	1/2 Tie Rod	1
24	W-O008734	B/O RS Hood Bracket	1
25	M-S015150	Arrow Label	1
26	M-S015169	2 Arrow Sticker	1
27	W-O008590	RS Extrusion	1
28	M-S033064	On/Off/Momentary Switch	1
29	W-O008602	RS Main Frame	1
30	M-S033069	Sptd Rocker Switch	1
31	W-A008576	3 Pos Key Sw	1
32	M-S037020	115V USA Line Cord	1
33	M-S004029	8X1 Phil Mach Screw	8
34	W-A008656	RS Tractor Feed, Assy	1
35	W-O008614	B.O. 5/16 Tie Bar	1
36	W-O008615	Bottom/Platen Shaft	1
37	W-A008726	3.5-7 Sig.Plt.Hldr,Asm	1
38	M-O008516	Back-Up Roller	1
39	M-O008621	5/16 Square Drive Shaft	1
40	M-S037054	LH Tractor Feed	1
Not Shown			
M-O008571	RS Bottom Extrusion	1	
M-S021024	115vac Motor	1	
M-S045027	2 Amp Fuse,3ag	1	
M-S030021	Rubber Foot	4	
M-S035015	Strain Relief #Sr-5p-4	1	
W-O008606	Bottom Cover	1	
M-S025008	144x1037 Timing Belt	1	
M-S045040	Battery For Counter	2	
M-O008543	Nylon Gear	1	
M-S013040	Oilite Bushing 3/4X1X3/4	1	
M-S022024	Pulley 32x312 Bore	1	
M-S022025	28t Pulley,1/4"ID	1	
M-S022026	10x1037 G Pulley	1	
M-S033040	Microswitch	2	
M-S035006	Snap Bushing	2	
M-S035022	Panel Bushing,UB-625	1	
M-S045016	Fuse Block	1	
W-O008654	Nylon Gear	1	

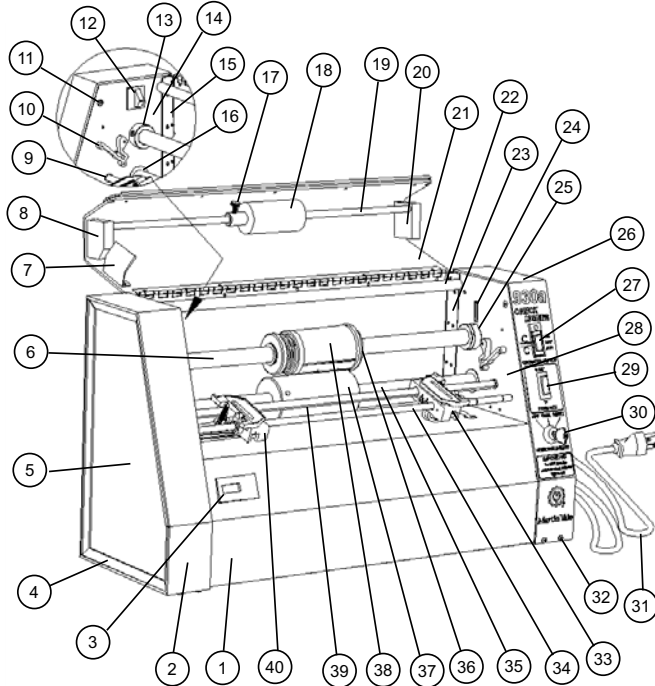

* Signature plates ordered separately, see enclosed order form.

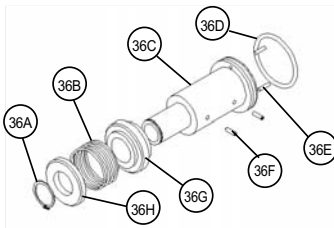

36	W-A008726	3.5-7 Sig.Plt.Hldr,Asm	
A	M-S010013	5100-100 Ext Snap Rg	1
B	M-O008538	Sig Plt Spring	1
C	M-O008670	Signtr Plate Holder	1
D	M-S023016	#224 O-Ring Epdm	1
E	M-S018001	1/8d X 1/2 Rollpin	2
F	M-S002055	10-32x3/16 Brass Tip	2
G	M-O008611	Retainer-Sign,Plate	1
H	W-A008617	Turn, Spring Retainer	1



**CHECKSIGNER 930A
 OPERATING INSTRUCTIONS
 &
 PARTS LIST**



FEATURES

- TRACTOR FEED DRIVE FOR ACCURACY
- L.C.D. COUNTER WITH MEMORY
- DUAL SIZE SELECTOR SWITCH
- POWER-ON INDICATOR LAMP
- FULLY ADJUSTABLE IMPRESSION LOCATION
- FULLY FUSED ELECTRICAL COMPONENTS
- TRI-COLOR INK ROLL (Optional)
- KEY-LOCK SECURITY
- IMPACT-PROOF LEXAN HOOD
- SILENT BELT MOTOR DRIVE
- FAN-COOLED MOTOR

SPECIFICATIONS

DIMENSIONS:	Height	12 9/16"
	Width	23"
	Depth	7 5/8"
WEIGHT:	30 lbs.	
ELECTRICAL RATING:	115 Volts, 60 Hz., 2.0 Amps.	
FORM SIZE:	Length	Width
	3 1/2" or 7"	16" Max - 3 1/2" Min.
SPEED:	14,280	3 1/2" Forms per Hour



251 Wedcor Avenue • Wabash, Indiana 46992
 Phone (260) 563-0641 • Fax (260) 563-4575

Email: info@martinyale.com • Website: www.martinyale.com



INTRODUCTION

Thank you for purchasing a Martin Yale Model 930A Check Signer. This signer has been designed and developed for easy operation and maintenance. However, we recommend that you familiarize yourself with the machine and carefully read these instructions.

OPERATOR SWITCH WITH INDICATOR LIGHT: (fig. 1)

The purpose of this switch is to jog the machine and put it in the off and on position. The red indicator light with the switch shows that the machine is in the "ON" position. When the switch is in the "on" position, the machine will automatically operate and sign forms.

FORM SIZE SWITCH:

This switch has 2 positions for form sizes: 3 1/2" and 7". To operate the machine, the form size switch must be in one of the two form size positions.

SELECTOR SWITCH:

The selector switch provides the functions of resetting the counter and turning the machine off. To operate the machine, the selector switch must be in the sign position.

ARROW ON MAINFRAME AND 2 ARROW COLLAR:

These are situated on the right side mainframe of the machine and on the 3/4" set collar (fig 1). The purpose of these arrows is for aligning the forms on the machine.

TRACTOR ADJUSTMENT PROCEDURE

NOTE: DISCONNECT POWER SUPPLY.

1. Open the hinged covers on the right & left tractor feeds.
2. Release the lock lever on the left tractor feed by pulling the tractor feed release lever forward.
3. Place the appropriate width form over the right tractor feed index pins. Close the cover.
4. To adjust for form width, slide the left tractor feed to align with the form holes on the opposite side of the form. Align the tractor feed index pins and close the hinged cover.
5. Slide the tractor feed as far left as possible. Avoid excessive side tension on the form. Push the tractor feed release lever toward the rear of the machine.
6. Open the hinged covers and remove the form.

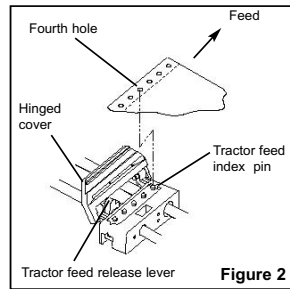

Figure 2

SIGNATURE PLATE INSTALLATION

(CONNECT THE POWER SUPPLY CORD TO 110-115V. OUTLET.)

1. Insert the key into the selector switch and rotate to sign position.
2. Jog the machine using the operator switch until one of the index pins on the signature plate retainer is on top.
3. Raise the hood by lifting upwards in center.
4. Slide the retainer collar to the left. Install the signature plate over the rollpin. Release the retainer collar.

- NOTE:** Signature plate(s) must be indexed on the rollpin prior to machine operation.
5. Close the hood and jog the machine to the next rollpin.

Form size:

- | | | |
|--------|---|-----------------------------|
| 3 1/2" | - | 2 signature plates required |
| 7" | - | 1 signature plate required |

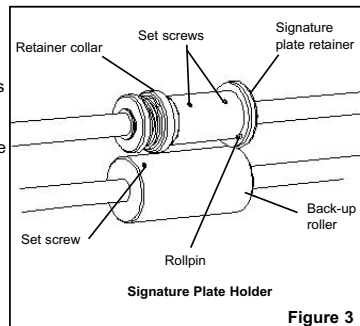

Figure 3

IMPRESSION LOCATION ADJUSTMENT

To adjust the location of the signature, a 2 arrow collar and start arrow (fig. 1) have been installed on the machine. Jog the machine to line up the proper collar arrow with the mainframe arrow. Select the proper size form on the form size switch. Place the form over the tractor feed index pins exposing 3 holes past the end of the tractor feed (fig. 2).

NOTE 1:

Jogging to remove the last form will be necessary when in the run position on the last check.

NOTE 2:

Before the next step, always jog the machine to align the form on the 2 arrow collar with the mainframe arrow.

IMPORTANT:

DO NOT LOAD THE FORM INTO THE MACHINE WHILE THE RED LIGHT IS ON. THE MACHINE WILL RUN IF THE OPERATOR SWITCH IS ON AND THE TRACTOR FEED SWITCH IS ACTIVATED.

If the signature is off, loosen the 2 set screws on the signature plate retainer (fig. 3) and 1 set screw on the back-up roller. Rotate the signature plate retainer or if necessary move the signature plate retainer side to side (keep the back-up roller in alignment with the signature plate retainer at all times). Lock the set screws and test run forms thru the machine.

INK ROLLER ADJUSTMENT

Before operating the machine, the ink roller must be aligned to contact the signature plates. There are two adjustments on the ink roller. A thumb screw is provided next to the roller itself to move it across the shaft. In addition there are four (4) adjustment screws in the hood which adjust it up or down to contact the signature plate (fig. 4).

NOTE: Avoid excessive pressure on the signature plate.

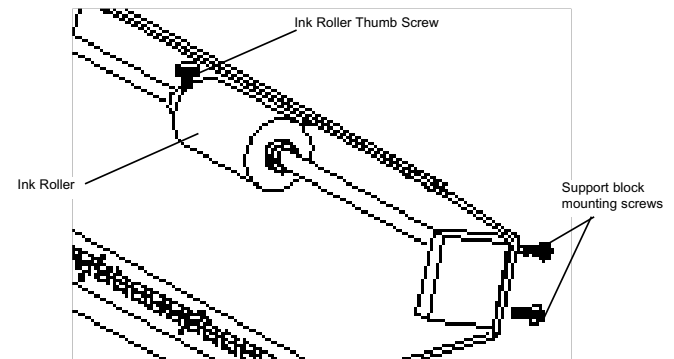

Figure 4

MAINTENANCE

OIL PERIODICALLY WITH LIGHT MACHINE OIL:

1. Signature plate shaft bushings.
2. Back up roller bushings.
3. Tractor drive shaft bushings.
4. Belt adjuster eccentric bushing. (Requires removal of left side cover).

CHECK DRIVE BELT TENSION ANNUALLY. (Requires removal of left side cover).

CLEAN TRACTOR DRIVE MICRO SWITCH OF PAPER DUST. (As required).

REPLACE BATTERIES IN COUNTER EVERY 3-5 YRS. (Requires removal of bottom cover plate).