



ProSource Packaging, Inc.
14911 Stuebner Airline Suite A
Houston, TX 77069
800-203-0233
www.Machine-Solution.com

SF2 Trimmer



Instructions & parts manual

CONTENTS

Introduction	3
Specifications	3
Safety	4, 5
Installation	6-8
Setup	9
Control Panel	10
Operation	11, 12
Maintenance	13
Adjustments	14
Fuses Access	15
Preventive Maintenance	15
Knife Removal & Installation	16-19
Clearing A Trimming Jam	19
Knife Care Tips	20
Notes	21
Trouble Shooting	22-25
Exploded Drawings & Parts Lists	26-40
Motor Wiring	41
Wiring Diagram	42
Electrical Schematic	43

INTRODUCTION

ISP Stitching & Bindery Products is proud to introduce another addition to its complete line of equipment for booklet making. Now you have the ability to trim books in-line! This combination offers you reliability and versatility that improves production and reduces downtime.

Trimmer Features:

In-line face trimming of booklets

Jam detection

Electrical interface for communication with ISP BookletMaker System

Safety interlock

See-through top cover

SPECIFICATIONS - MODEL: T3000 Trimmer

Unit Weight:	236 Pounds
Speed:	Up to 2,400 booklets per hour (115Vac machine)
Capacity:	Minimum 4.00" cut width x 4.13" to fold (trim length) 2 sheets 20# bond thickness Maximum 12.71" cut width x 9.00" to fold (trim length) 50 sheets 20# bond thickness (0.20") .625" maximum material trim
Booklets:	4.25" x 5.5", 5.5" x 8.5", 8.5" x 11", 4.75" x 4.75 "CD", & metric sizes (All booklets with or without trim stock on one or three sides)
Output:	Indexing conveyor
Footprint:	16.50" x 18.38"
Dimensions:	Height 27.38" Width 26.42" Length without discharge table 25.90" Length with fully extended discharge table 48.44"
Modes:	Trim or No-trim
Electrical:	Standard outlet - 115 Volts, 60 Hz, 6 Amps (1/4 HP) Optional: 230Vac, 50 Hz, 3 Amps

Trimmer

SAFETY

SAFETY PRECAUTIONS AND PROCEDURES

1. Make sure electrical power is turned off before performing any adjustment or maintenance.
2. Keep hands, hair, tools, and clothing clear of trimming area.
3. Become familiar with the moving components of your machine. Keep fingers away from areas that could pinch or cut.
4. ***BE EXTREMELY CAREFUL*** when changing the cutter knife. Severe lacerations or dismemberment could result from careless handling procedures.
5. ***NEVER REACH UNDER THE KNIFE*** Severe lacerations or dismemberment could result.
6. ***NEVER OPERATE THE TRIMMER WITHOUT THE T3000 BOOKLETMAKER AND SAFETY INTERLOCK SYSTEM.***
6. A well maintained machine is a safer machine. Clean and lubricate the machine at regular intervals. Check machine daily for broken or worn parts. Replace as necessary. DO NOT attempt to operate the machine if a part is broken.
7. See "SAFETY GUARDS" below! If you are unsure how to safely operate your trimmer, contact your Service Representative.



**KEEP HANDS CLEAR OF TRIMMING AREA AND ANY MOVING PARTS!
NEVER OPERATE MACHINE WITHOUT ALL GUARDS IN PLACE!**

SAFETY GUARDS (figs 1 & 2)

- A. Top Cover: Blocks access to mechanism that drives the trimming knife and conveyor belts. An electrical interlock keeps the machine turned off unless this guard is closed. Do not stick your fingers under the top guard!
- B. Front Upper Cover: Blocks access to the trimming knives and the mechanism that drives the upper trimming knife.
- C. Infeed Table Bottom Cover: Blocks access to infeed conveyor belts.
- D. Front Lower Cover: Blocks access to dangerous electric voltage and mechanisms that can pinch or cut. Be sure to disconnect electrical power before removing this cover.
- E. Right Side Cover: Blocks access to low voltage connections and mechanisms that can pinch or cut. Do not stick your fingers beyond this cover!
- F. Rear Upper Cover: Blocks access to dangerous electric voltage and control circuit connections. Be sure to disconnect electrical power before removing this cover.
- G. Rear Lower Cover: Blocks access to low voltage connections and mechanisms that can pinch or cut. Do not stick your fingers beyond this cover!
- H. Left Side Cover: Blocks access to low voltage connections and mechanisms that can pinch or cut. Do not stick your fingers beyond this cover!

SAFETY GUARDS

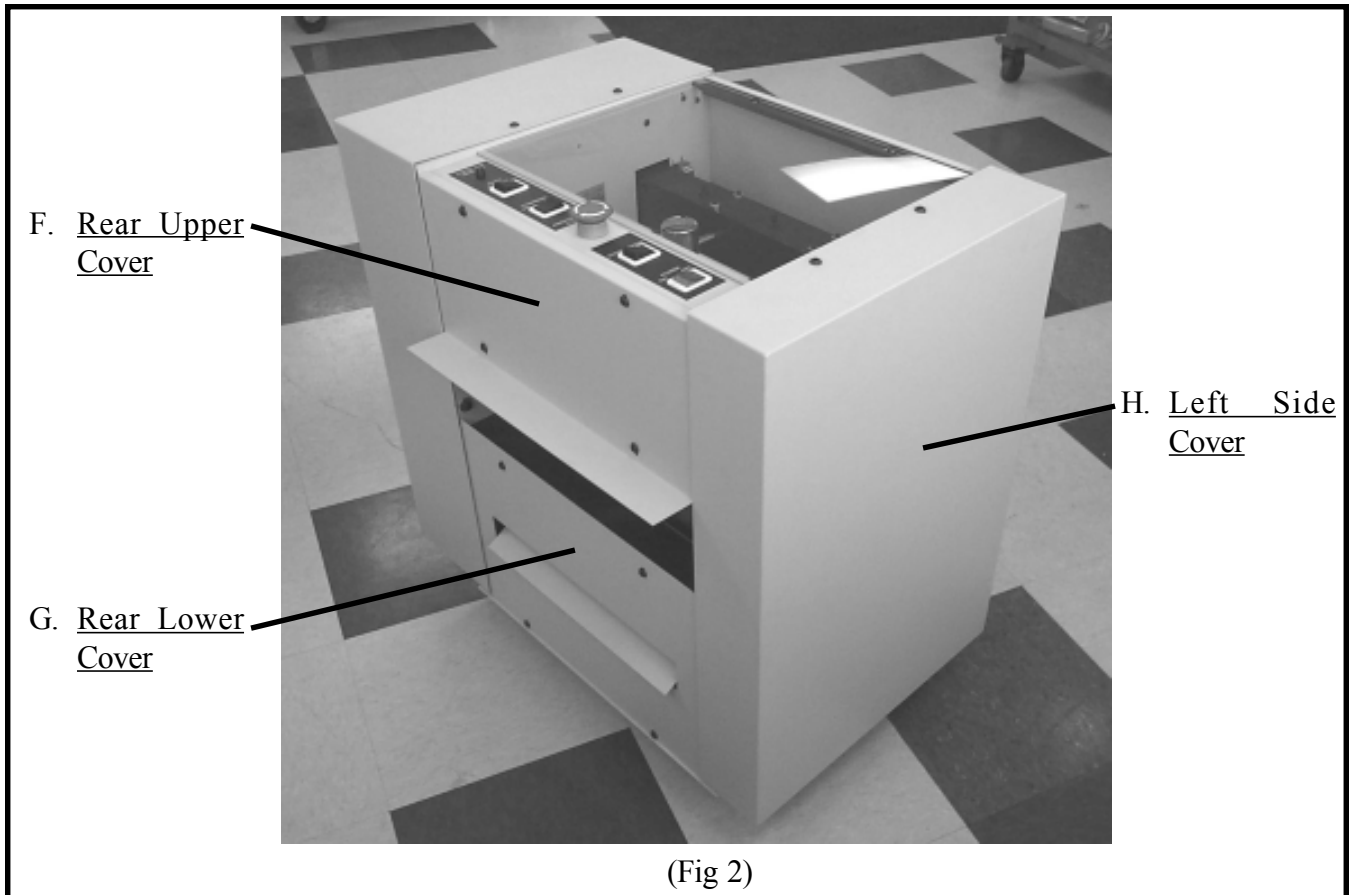
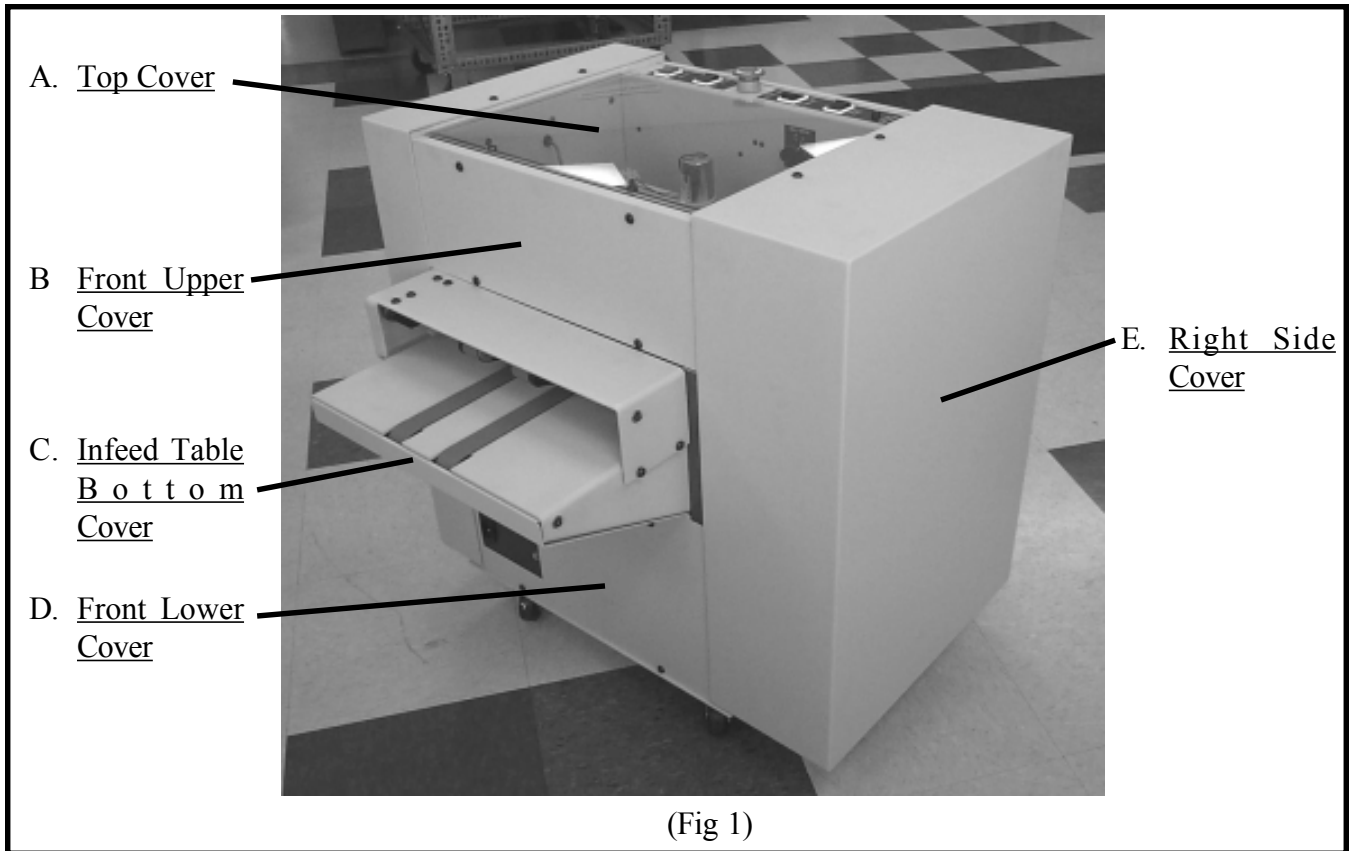

Trimmer

INSTALLATION

BEFORE UNCRATING:

Examine the crate for visible damage. If the crate is damaged, the machine might be damaged. Notify the carrier who delivered the machine.

UNCRATING THE MACHINE:

Carefully remove the machine from its container. Lift the machine by grasping its strong framework. Tugging on cables, covers, or other delicate components could cause damage.

Examine the machine for damages incurred during shipping. Do not install a damaged machine. Notify the carrier immediately, and be sure to get a signed copy of the Carrier Inspector's Report of the damage incurred. Your service representative will assist you in determining the cost of repairs.

ELECTRICAL POWER:

The power cord can be plugged into any 115V, 60 Hz, 1 Phase, 15 Amp circuit. The machine draws less than 6 amps.

SAFETY INTERLOCK SYSTEM:

WARNING
NEVER OPERATE THE TRIMMER
WITHOUT THE T3000
BOOKLETMAKER AND SAFETY
INTERLOCK SYSTEM CONNECTED.

Connect the safety interlock system as follows:

1. Remove the back cover (see fig 3) from the BookletMaker.
2. Put the bolt through the washer of the safety key assembly and screw the bolt half way into the back cover of the BookletMaker (see fig 4).
3. Install and securely tighten the nut onto the end of the bolt (see fig 5). The bolt must only be removeable by removing the nut first.
4. Install the back cover onto the BookletMaker (see fig 5).

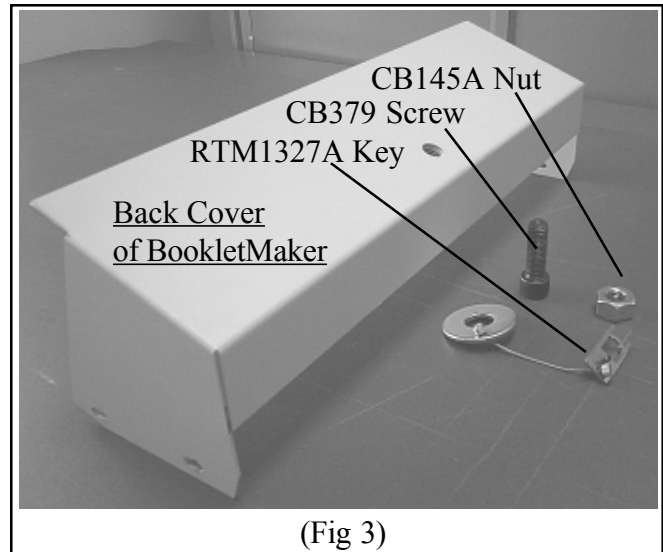

(Fig 3)

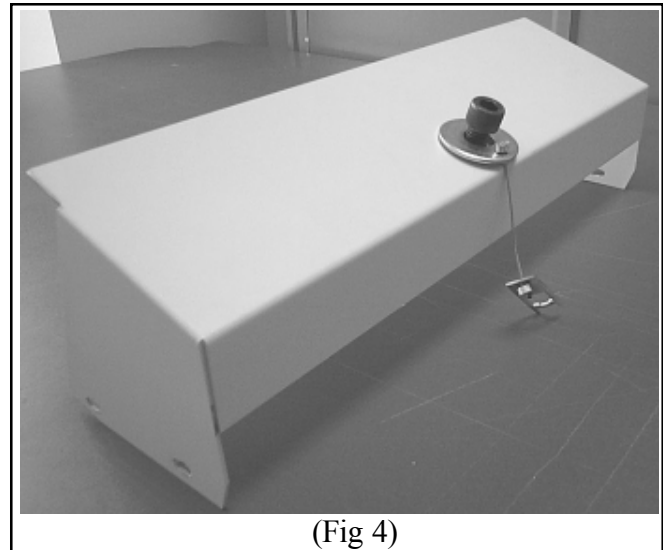

(Fig 4)

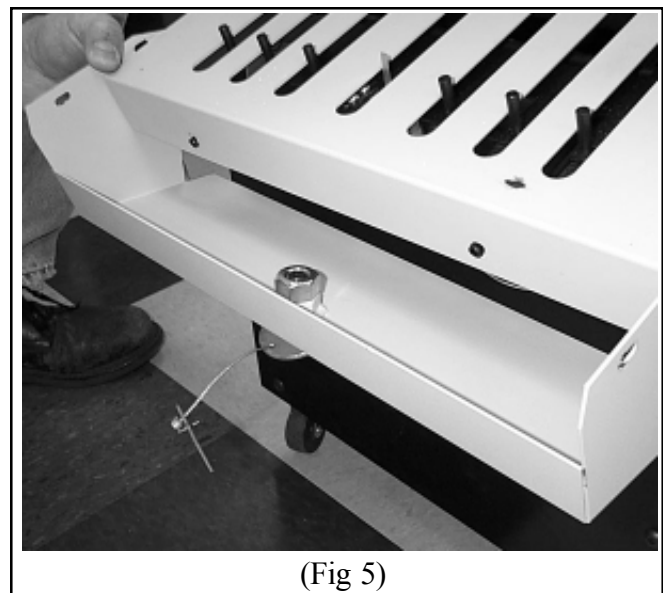

(Fig 5)

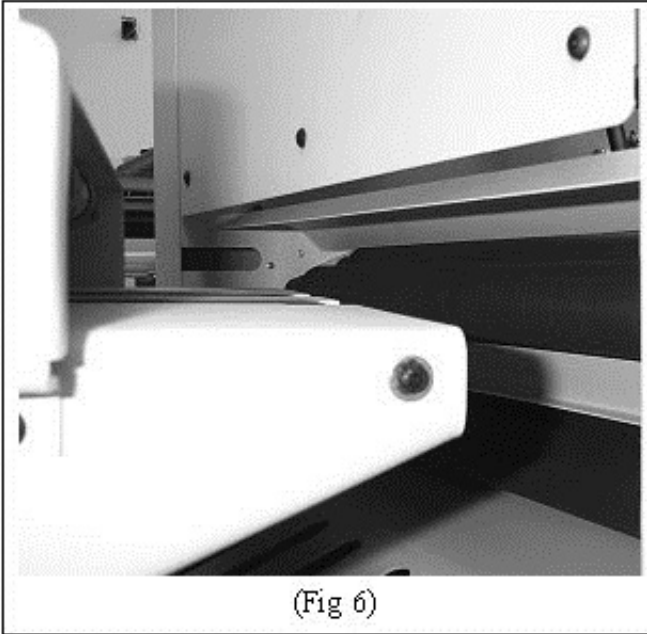

(Fig 6)

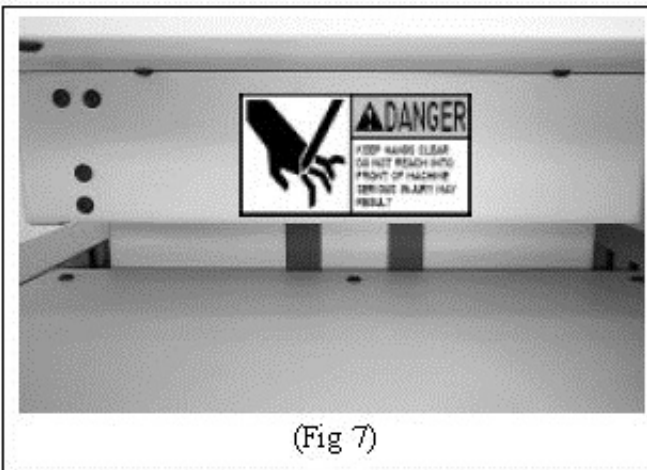

(Fig 7)

TRIMMER TO BOOKLETMAKER CONNECTIONS:

1. Adjust the height of the trimmer so that the top of the trimmer infeed table is about even with the middle of the BookletMakers top discharge roller (see fig 6).
2. Position the trimmer behind the BookletMaker so that the trimmer's infeed table is centered with the BookletMakers discharge, and slightly away from the BookletMaker's top discharge roller (see figs. 7&8).
3. Install the safety interlock key that is hanging from the bottom of the back cover (see fig 9).



(Fig 8)

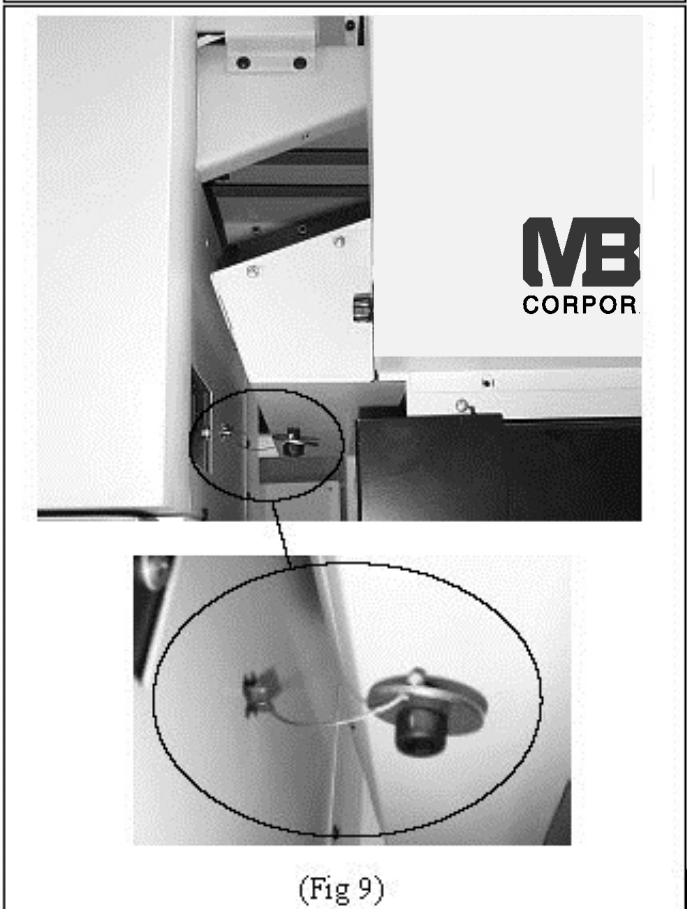

(Fig 9)

Trimmer

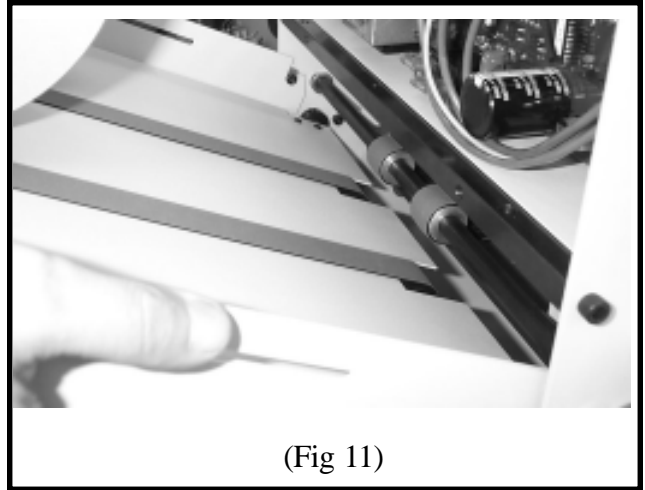
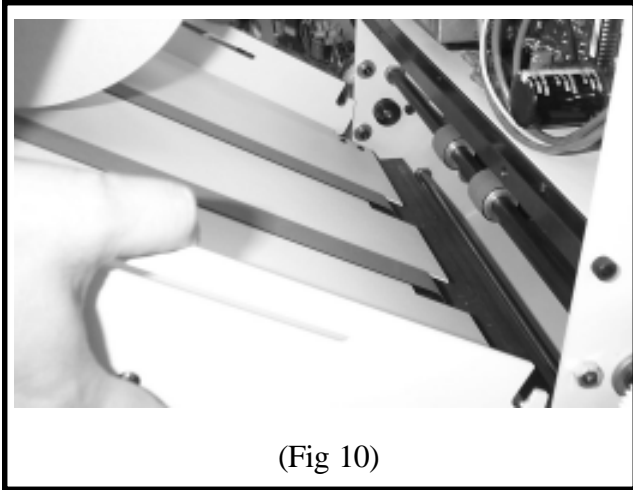

DISCHARGE CONVEYOR TABLE:

Install discharge conveyor table per illustrations (figs 10, 11, & 12).

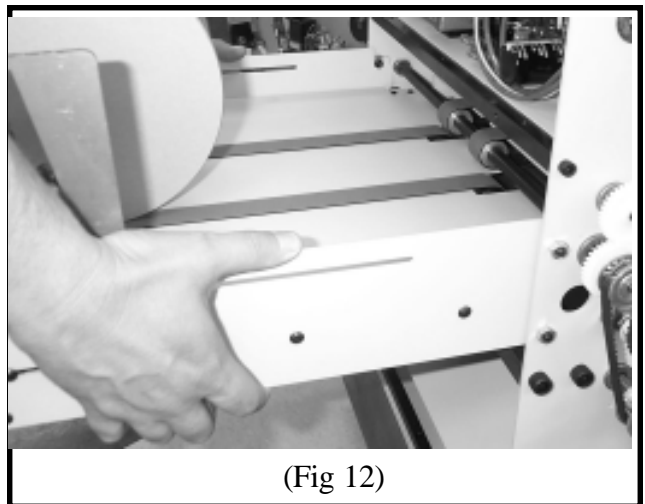

SETUP

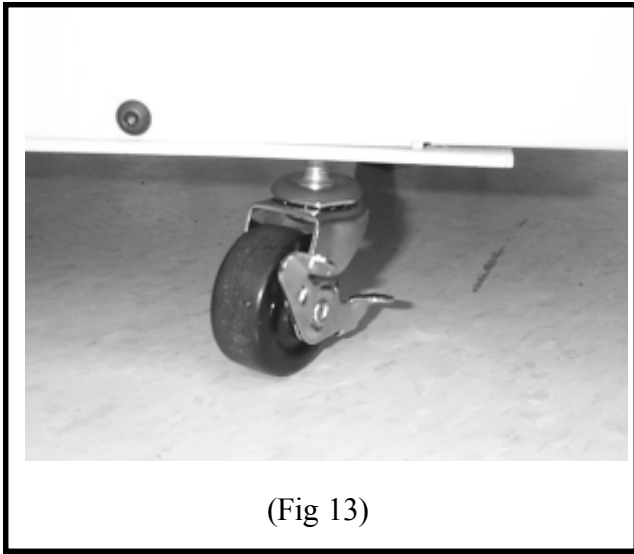

(Fig 13)

TRIMMER HEIGHT:

The height of the trimmer can be adjusted up or down slightly by use of the threaded adjustable casters and locking nuts on the bottom of the trimmer or trimmer stand (fig 13).

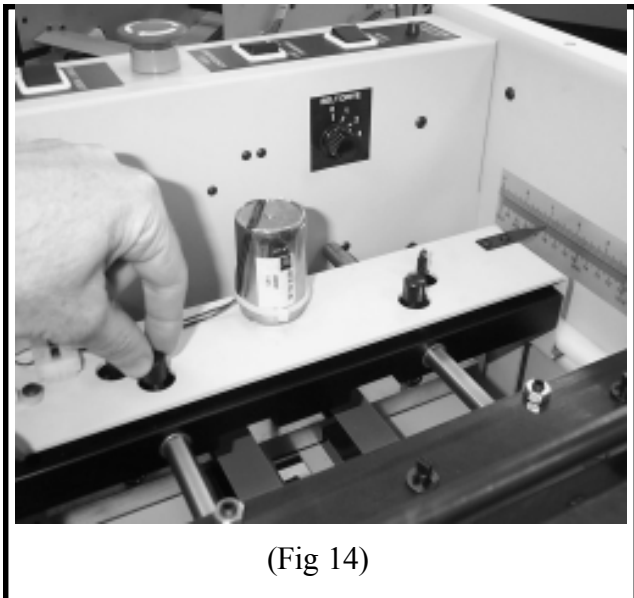

(Fig 14)

TRIM LENGTH:

To set the back stop assembly for the desired trim length, loosen the two thumb screws (fig 14) and slide the back stop assembly forward or backward

to the desired location. There is a pointer on the side of the back stop assembly that points to a trim length scale installed on the inside wall of the trimmer. Once located in the desired position tighten the two thumb screws.

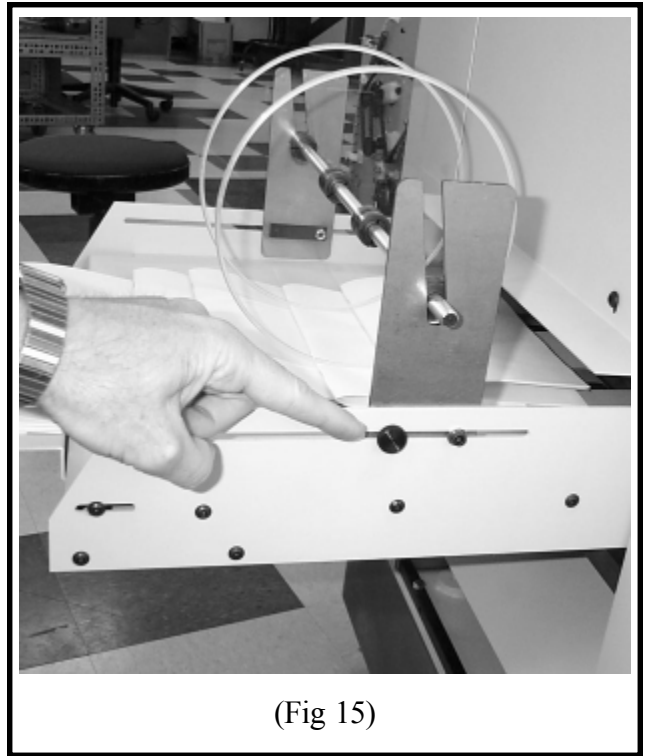

(Fig 15)

DISCHARGE TABLE ROLLERS:

Set the discharge table rollers forward for small booklets or backward for large booklets. To adjust the rollers, loosen thumb screws (fig 15), move roller brackets to desired location, then retighten thumb screws.

Trimmer

CONTROL PANEL (figs. 16 & 17)

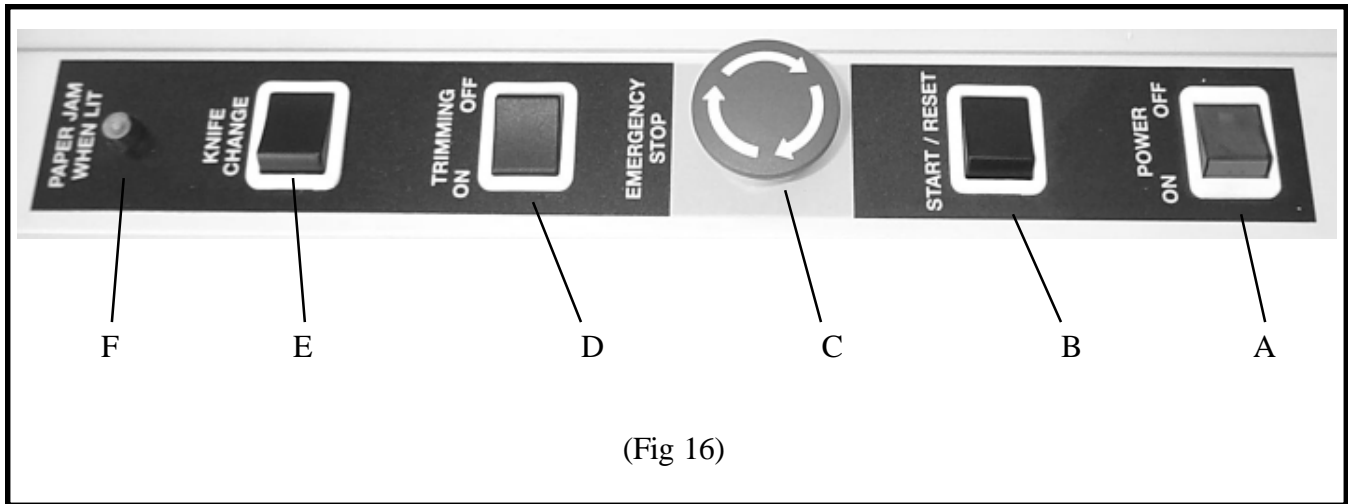

(Fig 16)

A. Power On/Off: Green rocker switch turns on or off power to the machine. Pilot light in switch glows when power is on.

B. Start/Reset: Black rocker switch energizes control circuit, which turns on motor. In addition, the discharge conveyor will run and the work gate will be raised as long as the switch is depressed.

Note: Opening the top guard shuts off the machine. It must be restarted as above.

C. Emergency Stop: Cuts off power to the machine's drive and control circuit when depressed. The Emergency Stop button locks in the down (off) position until manually turned allowing it to pop back up into the power on position. Restart machine per B above.

D. Trimming On/Off: Selector switch chooses mode of operation: "On" for trimming jobs or "Off" to allow work to pass through without trimming.

E. Knife Change: Black rocker cycles the trimming knife up and down as long as it is depressed.

F. Paper Jam When Lit: Glows to indicate that there is a paper jam.

G. Belt Drive: Rotary switch controls when the work conveyor belts shut off after incoming work is sensed. The choice range is 1 through 6. "1" for quick shut off to "6" for maximum extended running of the work conveyor belts after incoming work is sensed.

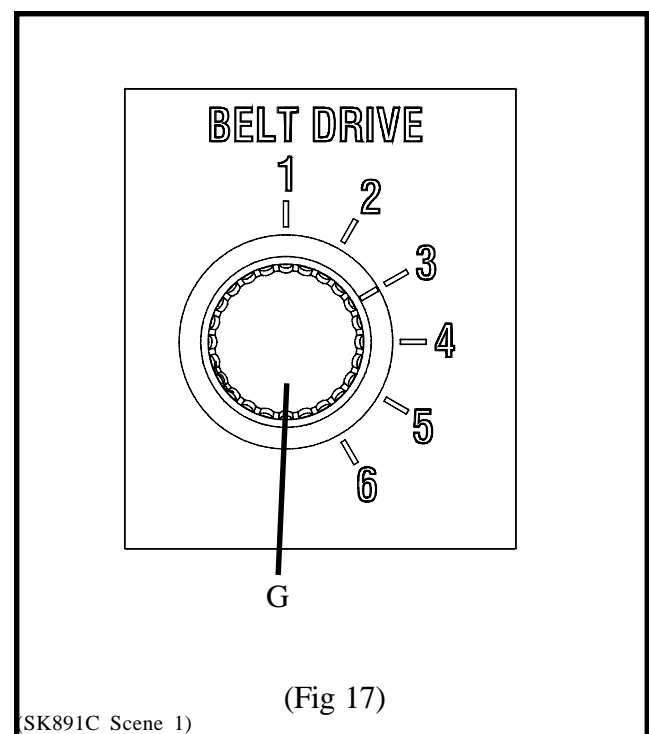

(Fig 17)

OPERATION

STARTUP:

1. The "BELT DRIVE" rotary switch should be set to "1" position.
2. Depress "POWER ON" switch to turn on power.
3. Depress "START/RESET" switch to energize control circuit. The electric motor will now energize and begin the infeed and internal conveyors.
4. Select "TRIMMING ON". Run the BookletMaker so that a booklet is deposited on the trimmer's infeed table. The booklet will be transported into the trimmer, trimmed, and ejected onto the output conveyor. The output conveyor runs for a short duration each time a booklet is sensed entering the trimmer. This ensures that there is no gap between work on the discharge table.

NORMAL OPERATION:

1. Work is deposited, from the BookletMaker, onto the trimmer's infeed conveyor table.
2. The infeed conveyor belts pull the work into the trimmer.
3. As the work is pulled into the trimmer, the work passes above photo sensor number one, located at the end of the infeed conveyor table. Number one photo sensor recognizes the work and tells the control circuit that work is entering the machine.
4. The infeed conveyor throws the work over the lower knife area and into the middle work conveyor belts.
5. The middle work conveyor belts pull the work over photo sensor number two, located near the work back stop gate. Number two photo sensor recognizes the work and tells the control circuit that work has entered the trimming area.
6. The control circuit then lets the conveyor belts continue to run, for a short period of time, to allow the work to run into and square up against the back stop gate. The conveyor belts are then stopped.
7. At this time the control circuit energizes the trimming clutch solenoid, which releases the trimming clutch to begin the trimming cycle.
8. The knife bar assembly begins to cycle down-

ward.

9. As the knife bar assembly cycles downward the gate clamp begins to squeeze, flatten, and hold the leading end (or fold) of the work. The front clamp then begins to squeeze, flatten, and hold the trim end of the work.
10. As the knife bar assembly continues downward the knife begins to cut/trim the work.
11. The knife bar then begins cycling back up to the top of its stroke (starting position).
12. As the knife bar approaches the top of its stroke, it passes the knife bar proximity sensor. The proximity sensor tells the control circuit that the knife bar has reached the top of its stroke.
13. The control circuit then deenergizes the trimming clutch solenoid which stops/ends the trimming cycle.
14. The control circuit then energizes the gate solenoid, which lifts up the gate, and energizes the infeed and middle conveyor belts.
15. The trimmed work is then conveyed out of the trimmer and deposited on the discharge table.
16. When the next work to be trimmed is sensed by number one photo sensor (on infeed table) the control circuit energizes the discharge table clutch for a short time. While the discharge clutch is energized it runs the discharge table conveyor belts. The belts move the work on the discharge table a short distance. The control circuit then cuts power to the discharge table clutch. The discharge table conveyor belts and work stop moving until the next piece of work to be trimmed causes the discharge table cycle to repeat.

JAM DETECTION:

If the work does not finish passing over number one photo sensor, within normal operating time, the control circuit recognizes this as a jam. The trimmer drive shuts off. The "PAPER JAM WHEN LIT" indicator light becomes lit. A normally closed relay in the control panel (used as the jam output to another machine or device) closes.

Trimmer



JAM CLEARING & RESTART:

1. Turn off power to the trimmer.
2. Remove work jam. **DO NOT REACH UNDER THE KNIFE! SEVERE LACERATIONS OR DISMEMBERMENT COULD RESULT.**

To manually remove a paper jam from the knife:

Turn off the power to the Trimmer

Remove the Right Hand side cover (RTM1101F)

Disengage Clutch (RTM1093F) by hand,

then using a wrench rotate the Knife Clutch Shaft (RTM1094F) clockwise by gripping the Manual Cycle Collar (RTM1349F). This should complete the cutting cycle.

If after completing this cutting cycle the machine needs to be cycled again, the clutch (RTM1093F) will need to be released by hand again.

3. Close all safety covers.
4. Depress "POWER ON" switch to turn on power.
5. Depress "START/RESET" switch to energize control circuit. The electric motor and conveyor clutches will energize so trimming may resume.

JAM OUTPUT:

When a jam occurs a normally closed relay in the control panel closes. This relay is connected to a .141" diameter female phone jack outlet (fig 18) located on the power cord bracket. Any device plugged into the phone jack will receive a closed circuit signal, which that device can use to shut down any upstream machines feeding work to the trimmer.

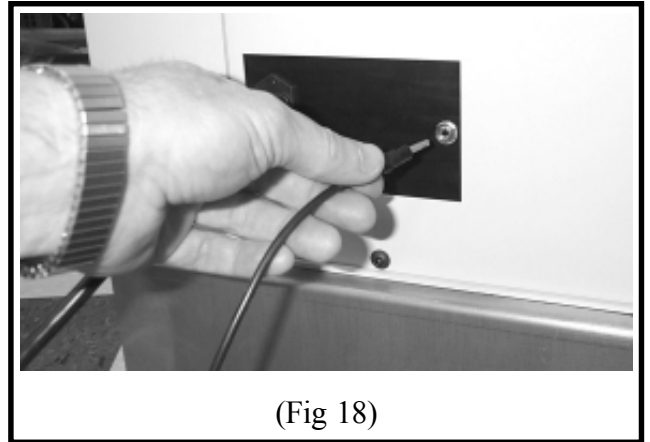

(Fig 18)

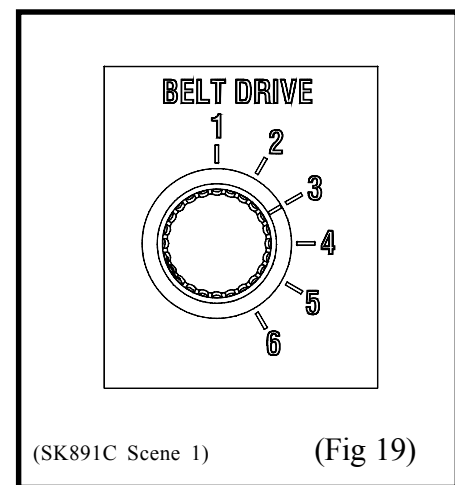

(SK891C Scene 1)

(Fig 19)

BELT DRIVE:

The purpose of the "BELT DRIVE" rotary switch (fig 19) is to make sure the work will square up against the back stop to provide a good square cut booklet.

The "1" setting means that the internal conveyor belts will shut off quickly after the work is sensed allowing time for the work to square up against the back stop.

If the work does not square up fully against the back stop before being trimmed, rotate the switch to position "2". This position allows the internal conveyor belts to run for an additional short period of time (after the work is sensed) so that the work will square up before being trimmed.

Positions "3" through "6" allow for progressively longer conveyor belt running time for unusual work, such as work that may slip on the conveyor belts, to square up against the back stop.

MAINTENANCE

▲ NOTICE ▲

The instructions on the following pages are for the use of trained personnel only!

Attempting to perform repair and replacement procedures without proper training may cause machine damage or operator injury!

Trimmer

ADJUSTMENTS

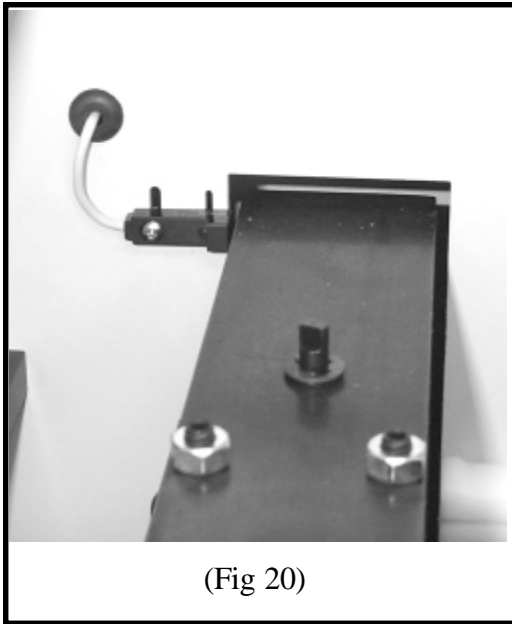

(Fig 20)

KNIFE BAR SENSOR ADJUSTMENT:

The knife bar must always stop at the top of its stroke in order for work to enter the trimmer. If the knife bar stops too low work will not be able to get past the front clamp and/or knife, and work jams will result.

The function of the knife bar sensor is to signal the control circuit when the knife bar has reached the top of its stroke so that the control circuit can denenergize the trimming clutch causing the knife bar to stop at the top of its stroke.

1. With power on and drive motor running, use the knife change toggle switch to jog the knife bar to the top of its stroke. If you can not stop the knife bar at exactly the top of its stroke, it is better to stop it slightly before top of stroke rather than after top of stroke.
2. Turn off and unplug power.
3. Remove the left cover.
4. Loosen the screws of the knife bar sensor, move the sensor so that the top of the sensor is even with the top of the knife bar (fig 20).
5. Reinstall the left cover.

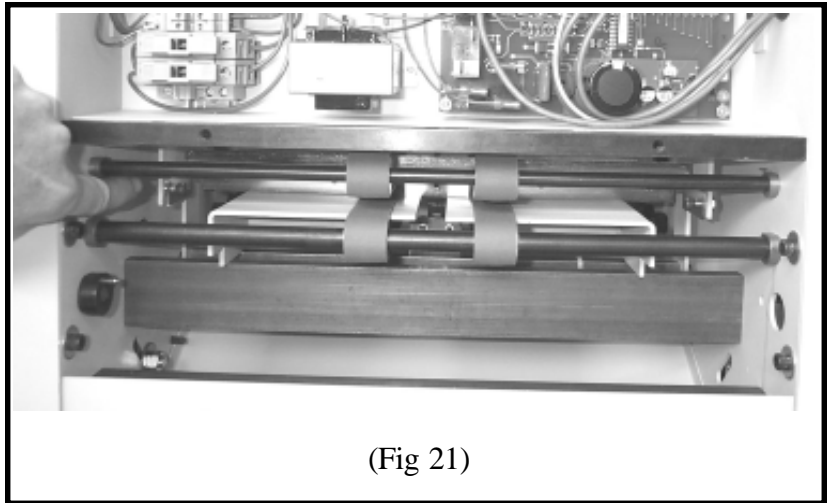

(Fig 21)

BACK STOP GATE ADJUSTMENT:

The function of the back stop gate is to provide a surface for the work to square up against so that the knife will cut the work squarely. The back stop gate must be parallel to the bottom knife.

1. Run several pieces of work through the trim cycle.
2. By looking at the work, determine how much one side or the other of the back stop gate must be moved forward or backward.
3. Turn off and unplug power.
4. Remove rear discharge table.
5. Remove rear upper cover.
6. Open top cover.
7. Slide backgate carriage to front of machine.
8. Using a 3/8" box wrench and a 1/8" hex wrench loosen and shift one of the shoulder screws (fig 21) locating the back stop gate (which will also shift the back stop gate) forward or backward the amount needed to square up the trim. Note: It may be necessary to first move one shoulder screw and then the other in order to obtain the maximum amount of adjustment.
9. Reinstall lower cover and discharge table.

FUSE ACCESS

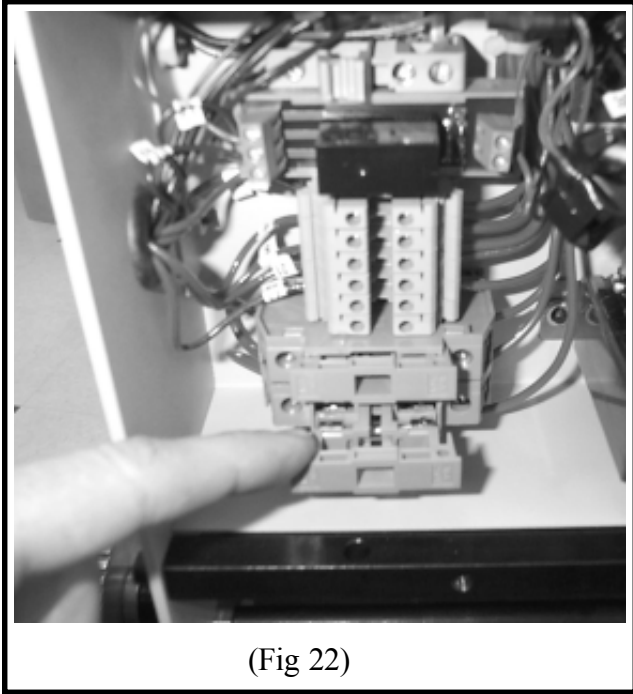

(Fig 22)

Turn power off and unplug the machine. Remove the rear upper cover (removal of four screws required) above the work discharge area of the machine. There are two fuse holders mounted on the din rail. To access the fuses, pull out the fuse compartment (fig 22) of each fuse holder and remove the fuses.

- A. Motor Fuse: Fuse protects the motor input lines of the machine. If this fuse fails, the motor will not run. Replace with 6 amp fuse ISP #RTM1303F for 115Vac machine or 3 amp fuse ISP #RTM1330F for 230Vac machine.
- B. Control Circuit Fuse: Fuse protects transformer. If this fuse fails, none of the 24VDC components will operate. Replace with 1 amp fuse ISP #RTM1302F for 115Vac machine or 0.5 amp fuse ISP #RTM1329F for 230Vac machine.

PREVENTATIVE MAINTENANCE

LUBRICATION:

Disconnect electrical power. Next, remove the front cover and both side covers.

Use SAE-20 oil to lubricate porous bronze bearings, plastic bearings, chains, shafts, and cutter bar linkages.

CLEANING:

Use alcohol to clean the belts.

HARDWARE:

Remove the covers to check all nuts and bolts for tightness. Loose hardware is the cause of most component wear and in the electrical area could cause short circuits and/or shock.

Trimmer

KNIFE REMOVAL & INSTALLATION

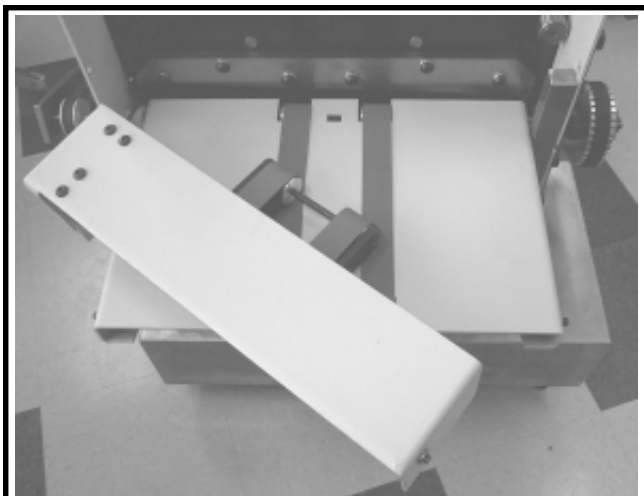

(Fig 23)

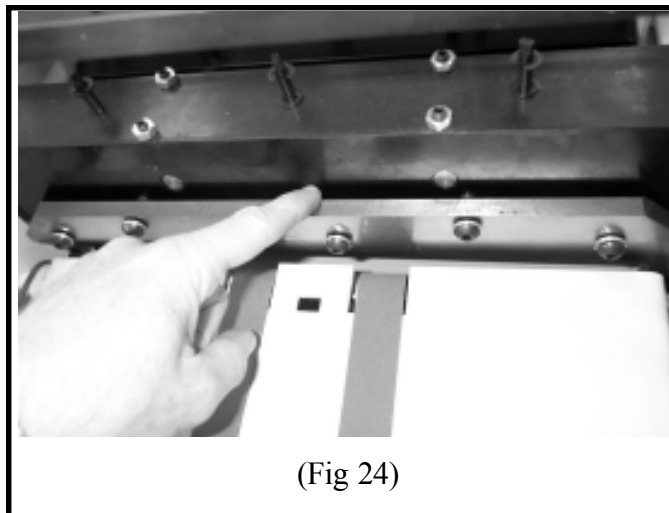

(Fig 24)

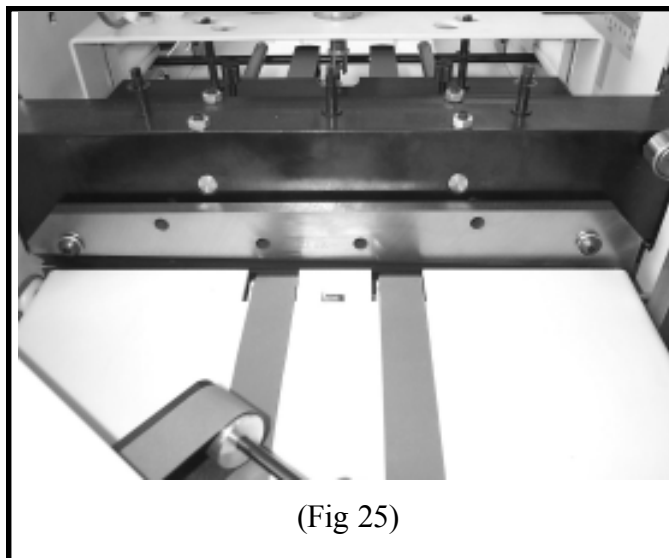

(Fig 25)

UPPER KNIFE REMOVAL & INSTALLATION:

CAUTION: Changing knives can be very dangerous unless safety precautions are observed and extreme care is taken when handling knives

Keep handling of unprotected knives to an absolute minimum.

Warn people of any unprotected knife.

Knife changing is a ONE PERSON OPERATION. Having more than one person trying to change knives invites accidents.

1. Use the "Knife Change" rocker switch to move the knife bar to the bottom of it's stroke.
2. Turn off power and unplug power cord.
3. Remove bottom cover of infeed table.
4. Remove front upper cover and the lower bar that the front upper cover attaches to.
5. Remove the left and right side covers.
6. Remove the four screws and nuts holding the top infeed table's conveyor bracket to the infeed table.
7. Carefully lift the right side of the upper infeed conveyor bracket off the infeed table. Swing it out and lay it on the infeed table (fig 23). NOTE: Be sure the round belt does not come off pulleys and be sure the separating finger stays between belts where they cross or the infeed table conveyors will not operate properly when reassembled.
8. Loosen, BUT DO NOT REMOVE, all upper knife screws so that the upper knife can be slid away from the knife bar on the screws about 1/8 inch (fig 24).
9. Remove only the four middle knife screws so that the two end screws remaining are holding the knife about 1/8 inch away from the knife bar (fig 25).
10. Insert a strong length of wire through the top right screw hole in the knife. Pull the wire

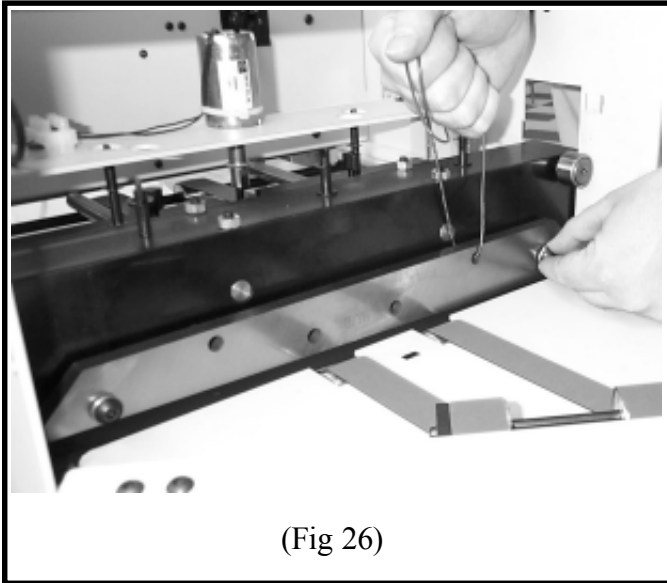

(Fig 26)

through and securely tie the wire ends to make a strong secure handle that will be used to lift that end of the knife when the right screw is removed (fig 26).

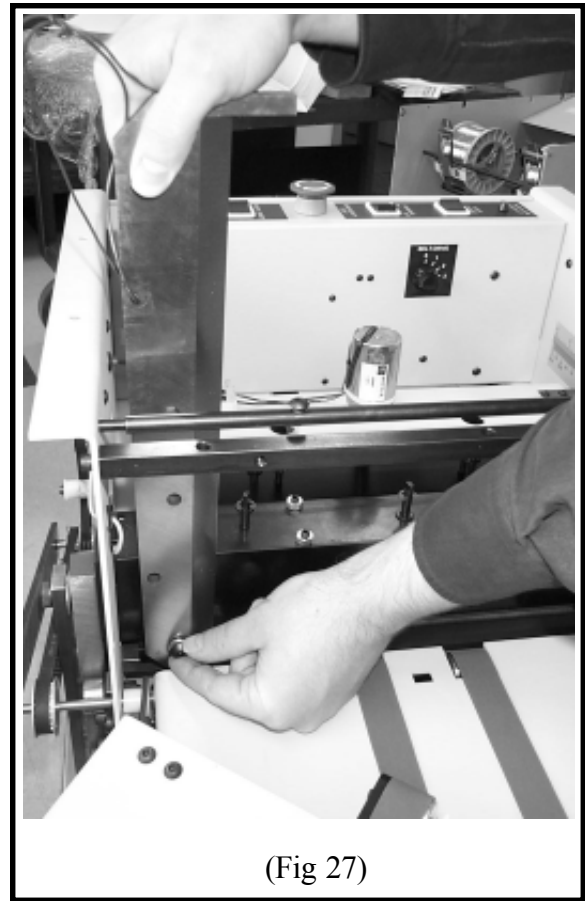

(Fig 27)

DANGER

NEVER PUT HAND OR FINGERS BELOW KNIFE WHEN REMOVING OR INSTALLING. SEVERE LACERATIONS OR DISMEMBERMENT COULD RESULT.

11. Hold securely onto the wire handle and remove the right knife screw.
12. Use both hands to swing knife up, while pivoting on remaining lower left hand knife screw.
13. While holding knife securely with one hand, remove last knife screw, and remove knife from trimmer (fig 27).
14. Put blade in the scabbard immediately and secure the knife retaining screws.
15. Reverse this procedure to install upper knife.

LOWER KNIFE REMOVAL:

THE UPPER KNIFE MUST BE REMOVED (per steps 1-13 of Upper Knife Removal page 13 & 14) BEFORE THE LOWER KNIFE IS REMOVED.

CAUTION: Changing knives can be very dangerous unless safety precautions are observed and extreme care is taken when handling knives

Keep handling of unprotected knives to an absolute minimum.

Warn people of any unprotected knife.

Knife changing is a ONE PERSON OPERATION. Having more than one person trying to change knives invites accidents.

1. Once the upper knife is removed, cycle the knife bar back up to the top of it's stroke by manually releasing the trim clutch and turning the large pulley on the clutch clockwise (fig 28) until the knife bar is all the way up.
2. Loosen the five screws securing the lower knife (fig 29).
3. Remove the lower knife.

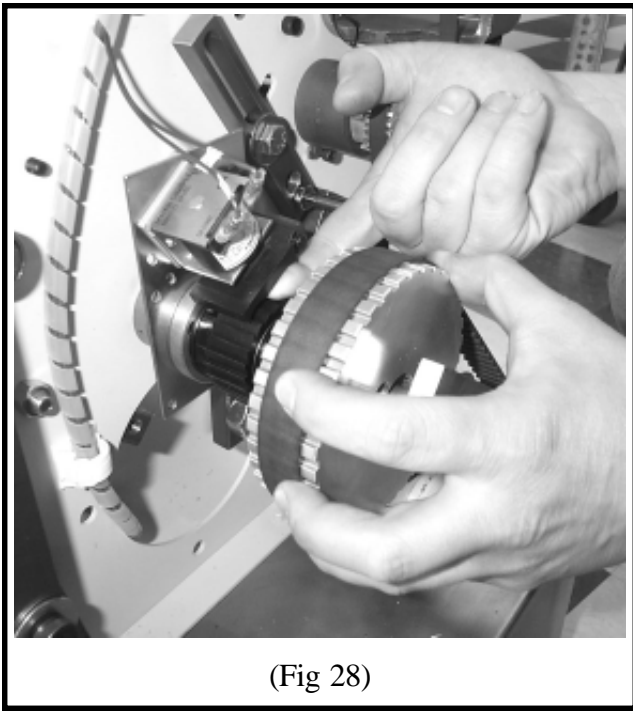

(Fig 28)

LOWER KNIFE INSTALLATION & ADJUSTMENT:

THE UPPER KNIFE MUST BE REMOVED (per steps 1-13 of Upper Knife Removal pages 15-16) BEFORE THE LOWER KNIFE IS INSTALLED.

1. Once the upper knife is removed, cycle the knife bar back up to the top of it's stroke by manually releasing the trim clutch and turning the large pulley on the clutch clockwise (fig 28) until the knife bar is all the way up.

WARNING
TURNING THE CLUTCH PULLEY COUNTER CLOCKWISE AND/OR THE KNIFE PULL DOWN DRIVE SHAFT IN REVERSE WILL DAMAGE THE CLUTCH.

2. If installing a new or different lower knife, the set screws which push the lower knife forward against the upper knife, must be turned out so that the lower knife will not be in the way of the upper knife cycling down.
3. Install the five lower knife flat washers and screws, but do not fully tighten because the lower knife must be free to move during the next steps of installation/adjustments.
4. Manually cycle the knife bar (similar to step one) to the bottom of it's stroke. Install and secure the upper knife per upper knife removal & installation procedure page 13 & 14
5. Push lower knife firmly against the upper knife. Turn the lower knife adjustment set screws gently against the lower knife and secure with the nuts. Manually release the trim clutch and turn pulley until knife bar is at top of stroke.
6. Tighten the lower knife securing screws. **DO NOT PLACE FINGERS OR HAND BELOW UPPER KNIFE.**
7. Manually release the trim clutch and cycle the

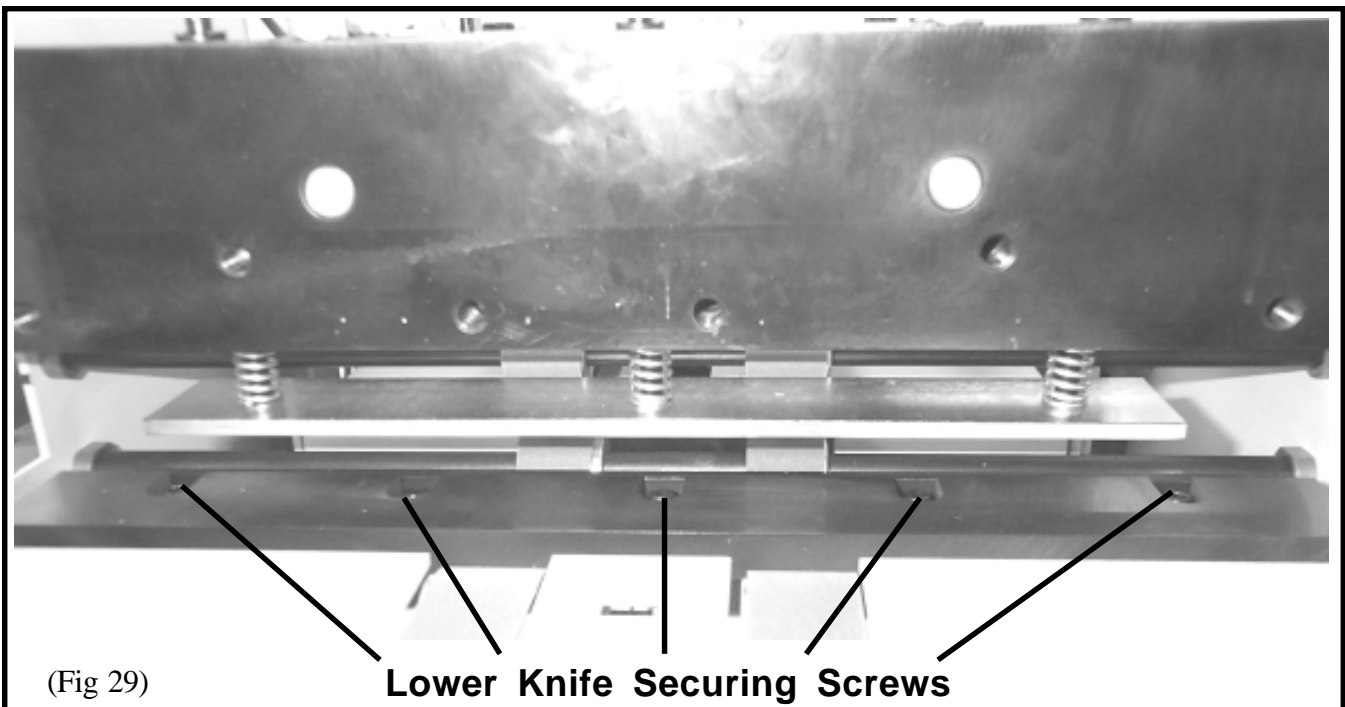

(Fig 29)

Lower Knife Securing Screws

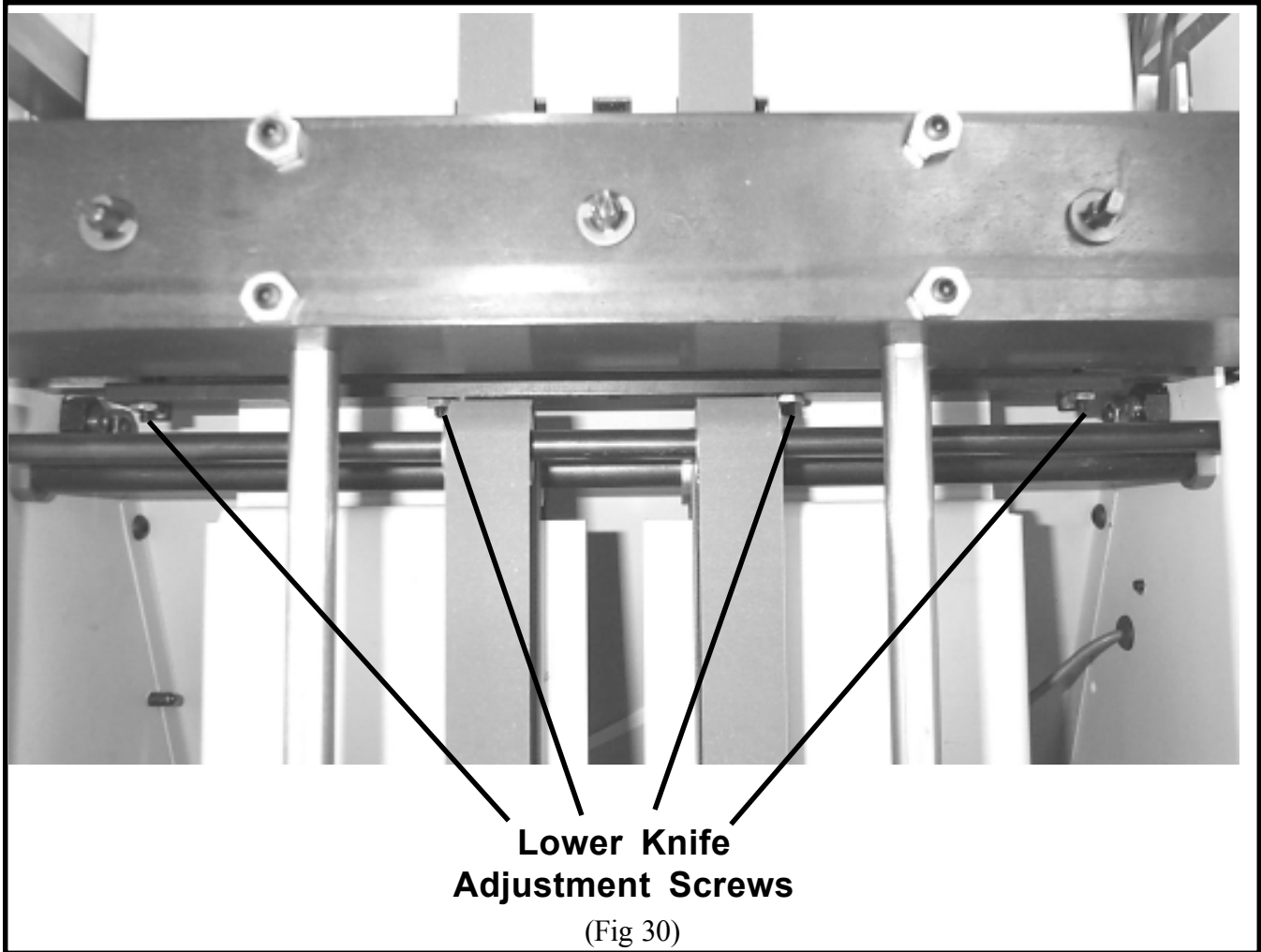

knife bar through one cycle to check that the upper knife blade passes the lower knife smoothly without obstruction.

8. Place a single sheet of paper (large size) between the upper and lower knives, manually release the trim clutch and cycle the knife bar through one cycle. **KEEP HANDS CLEAR!**
9. Check that a clean cut is obtained across the full width of the knife blades.
10. If necessary loosen the lower knife securing screws at the point where adjustment is needed. Loosen the lower knife bar adjustment screws/nuts, move the lower knife closer to the upper knife by turning the appropriate adjustment screw (fig 30) (1/6 turn at a time), retighten lower knife securing screws and nuts of adjustment screws.
11. Perform another test cut and make further adjustments if necessary.

CLEARING A TRIMMING JAM:

If the maximum capacity of the trimmer is exceeded (50 sheets of 20# stock or 0.20" work thickness) the trimming knife will stall near the bottom of the trim cycle and not finish cutting the work. If this happens the jam should be cleared by removing the upper knife (follow steps 2 through 15 of UPPER KNIFE REMOVAL & INSTALLATION procedure page 16) and finishing the trim cycle by hand (follow step 1 of LOWER KNIFE INSTALLATION & ADJUSTMENT procedure page 18).

WARNING

DO NOT TRY TO CLEAR THE TRIMMING JAM BY TURNING THE CLUTCH PULLEY COUNTER CLOCKWISE AND/OR BY TURNING THE KNIFE PULL DOWN DRIVE SHAFT IN REVERSE OR **THE CLUTCH WILL BE DAMAGED.**

Trimmer

KNIFE CARE TIPS

CAUTION: KNIFE SAFETY! Knives are **DANGEROUS!!!** They are heavy and very sharp, even after use. Keep the edge away from your body and keep the area clear of other people when handling knives. Never touch the cutting edge! To prevent personal injury and damage to the knife, always keep knives in their holders with screws tightened. Others entering the area may not be aware of the dangers. Never attempt to hone, polish, or service the knife in any way. Failure to follow safety procedures may result in severe lacerations or dismemberment.

Knife blade life, or the time between sharpenings, can be affected by many factors. One important factor is the type of paper being cut. Abrasive paper, such as recycled paper, soft paper such as newsprint paper, and bound books can all significantly shorten knife blade life. Cutting pure paper, such as bond paper with no recycled content will cause less wear on the cutting blade. In all cases the operator should continually check the quality of the cut to determine when the knife needs to be sharpened. Some characteristics that indicate a blade needs sharpening are:

The knife hesitates or stalls while making a cut.

The top sheets are not all cut to the same length (usually the top few sheets are longer than the rest of the sheets - this is sometimes called "draw")

Cut marks appear on the cut face of the paper.

The knife and/or drive makes a "rough" sound as the knife passes through the paper.

Nicks are visible on the cutting edge of upper or lower knife.

To prevent corrosion, knives are coated with light oil. It should be **REMOVED WITH CARE**.

While removing or installing a knife, be careful not to allow the cutting edge to bump against the machine or other knife. Nicks will result.

If a knife bolt is damaged, replace it.

Always keep knife bolts securely tightened.

Store knives in a dry environment to prevent corrosion.

Never attempt to service a knife in any way without proper training. It is recommended to maintain a spare set of knives as a back up.

NOTES:

Trimmer

TROUBLESHOOTING

PROBLEM:	SOLUTION:
1. The trimmer will not turn on.	1. Plug unit into appropriate power supply. 2. Depress the "Power On/Off" switch. 3. If there is no green light: <ol style="list-style-type: none"> Check for proper line voltage. (115V or 220V) Make sure the top guard is closed. Check the 1 amp control circuit fuse. 4. The green light is on, but the motor does not run. <ol style="list-style-type: none"> Depress the "Start/Reset" toggle switch. Check the 6A (115V) or 3A (220V) motor fuse.
2. Work is conveyed through trimmer without being trimmed.	1. Depress the "Trimming On/Off" switch to the "On" position. 2. Trim/Cut clutch problem. <ol style="list-style-type: none"> Check the connections at the clutch and circuit board. 3. Photo sensor problem. <ol style="list-style-type: none"> Check the connections at the sensor and circuit board. 4. Control circuit board problem. <ol style="list-style-type: none"> Check that knife bar begins cycle at top of stroke.
3. Trim is not square to book.	1. The work does not stop flat against the back stop gate. <ol style="list-style-type: none"> Check that knife bar begins cycle at top of stroke. Make sure all lower and upper conveyor belts on the infeed table and middle conveyor area are clean and operating properly. Switch the "Belt Drive" rotary switch to the next higher number position. 2. Backstop gate is not square to lower knife. 3. Dull and/or damaged upper and/or lower knife.
4. Work is not trimmed clean.	1. Lower knife not adjusted properly to upper knife. 2. Dull and/or damaged upper and/or lower knife. 3. The proximity switch that senses the knife bar needs to be adjusted upward.
5. The upper knife does not go up far enough to allow the work to pass below.	1. Gate photosensor is being activated by an internal shaft, while in the shortest trimming position. Verify by removing

<p>6. Jam detection shuts down machine when paper crosses over infeed photosensor.</p>	<ol style="list-style-type: none"> 1. Gate photosensor is being activated by an internal shaft, while in the shortest trimming position. Verify by removing the back cover of the trimmer, and observe that L7 on the circuit board is off. See page 24. <ol style="list-style-type: none"> a. Move trimming position to the min. 4" trim width. b. Remove a pair of flat washers (item 32 on page 31). 2. Gate photosensor is being activated by the gate clamp. <ol style="list-style-type: none"> a. Add a pair of flat washers (item 32 on page 31).
<p>7. Knife stalls near bottom of trim cycle and does not cut through work.</p>	<ol style="list-style-type: none"> 1. Maximum work thickness has been exceeded. See "CLEARING A TRIMMING JAM" on page 19.

Trimmer

Circuit Board: Light Layout

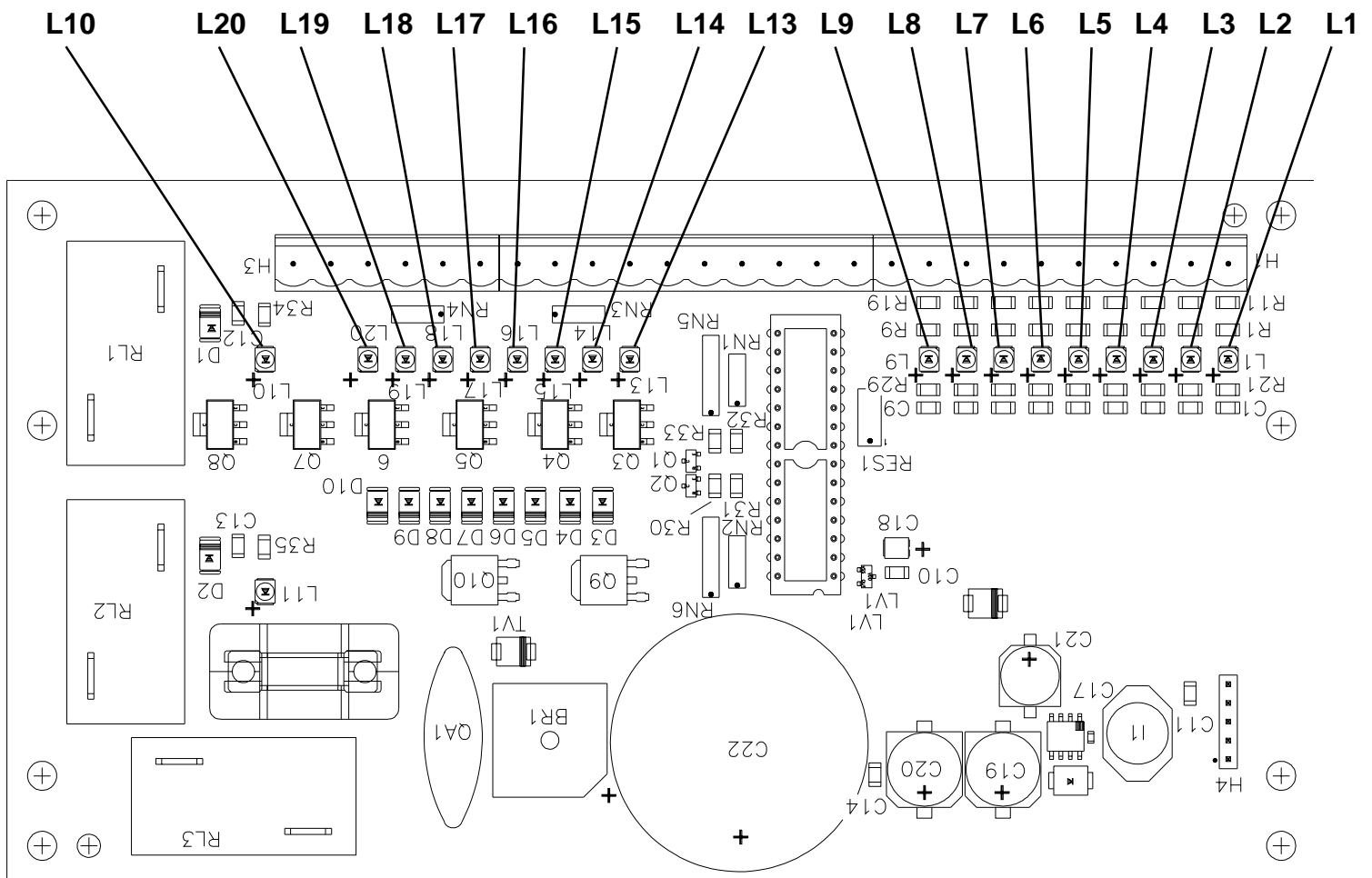

(RTM1172A-Layout1)

INPUTS L1-L9 (Yellow)

<u>LIGHT</u>	<u>APPLICATION</u>
L1	Trim/No Trim Switch
L2	Knife Change Switch
L3	Knife Proximity Sensor
L4	Belt Drive Selector Switch
L5	Belt Drive Selector Switch
L6	Infeed Photosensor
L7	Gate Photosensor
L8	Start/Reset Switch
L9	Belt Drive Selector Switch

OUTPUTS L10-L20 (Red)

<u>LIGHT</u>	<u>APPLICATION</u>
L10	Motor Power Relay
L13	Jam Light
L14	N/A
L15	N/A
L16	Discharge Clutch
L17	Conveyor Clutch
L18	Jam Detector Relay
L19	Gate Solenoid
L20	Cut Clutch

Circuit Board: Normal Operation Light Sequences

<u>PROCESS PERFORMED</u>	<u>ILLUMINATED LIGHTS</u>	<u>SIDE NOTE</u>
1) Power Switch (on)	L3, L6, L7, L13, L18	Have the belt drive position switch (fig. 19) in the zero position, and also have the trimming switch on, this will produce the desired light configuration. When the switch is turned off there are no lights lit.
2) Start/Reset Button	L3, L6, L7, L10, L17	If holding the reset button down, L8, L16, and L19 will also be lit. If only pushed and released, the previously mentioned lights will only momentarily light. Both of these previously mentioned conditions remain true for any subsequent start/reset thereafter.
3) Emergency Stop	NONE	If the emergency stop button is twisted back into the nominal position, the lights will display as in process number 1.
4) Trimming Switch	See Side Note	If the trimming switch is on, the lights will look the same as in process 2. If the switch is off, the same is true but L1 is also lit.
5) Knife Change Switch	*L3, L6, *L7, L13, L18	If holding the button down, the knife will cycle up and down and the following lights will light. L2, L3, L6, L7, L10, L13, L16, L17, L18, and L20 (L3 and L7 will flash on and off simultaneously).
6) Belt Drive Knob	See Side Note	Starting at position 1: L4, L5, and L9 will be off. At position 2 L4 will turn on. At position 3 L4 will turn off and L5 will turn on. At position 4 both L4 and L5 will be on. At position 5 L4 and L5 will be off and L9 will turn on. At position 6 L4 and L9 will be on.
7) Open Lid	NONE	If the lid is returned to the closed position, the lights will display as in process 1.
8) Passing Work Through Trimmer	L10, See Side Note	Inputs: L6 first turns off and then relights. This is closely followed by L7 turning off, and then L3 turning off. Outputs: L17 turns off immediately followed by L20 turning on then off. This is followed by L16, L17, and L19 turning on and then L16 and L19 quickly turn off together. When done the light pattern should be that of process 2.
9) Infeed Photosensor	See Side Note	Covering the front infeed photosensor will turn off L6. If L6 is covered for approximately 5 seconds, the machine perceives a jam and L3, L7, L13, and L18 turn on.
10) Gate Photosensor	See Side Note	Covering the gate photosensor will turn off L7. The operational light sequence will follow that of process 8, but L6 will not relight before L7 turns off. Therefore if L6 and L7 are out together, all lights turn off except L3, L13, and L18. A jam occurs when both the gate and infeed photosensors are covered at the same time.
11) Auto Shut-Down	L3, L6, L7, See Side Note	If the machine is on and running but not being used for about 2 minutes, it will auto shutdown. L10 and L17 will turn off, and L13 and L18 go on.

* Denotes that the light may or may not be lit.

Trimmer

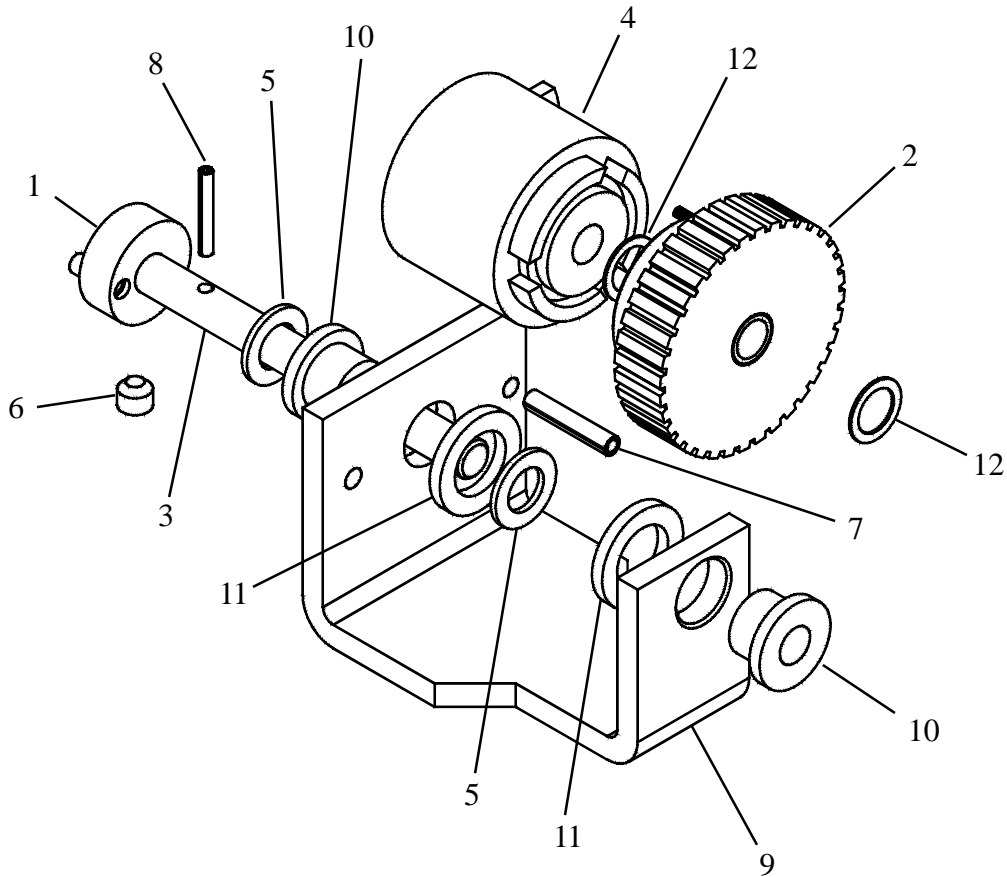

(RTM1286A Scene 2)

Index Number	Part Number	Part Name	Number Required	Index Number	Part Number	Part Name	Number Required
1	RBM1826A	Index Collar Assembly	1	7	D25524F	Roll Pin	1
2	RTM1264A	Pulley Assembly	1	8	D23940F	Roll Pin	1
3	RTM1261F	Index Shaft	1	9	RTM1286F	Clutch Mount Bracket	1
4	RTM1042F	Wrap Spring Clutch	1	10	RBM1778F	Bearing	2
5	CB2125	Nylon Washer	2	11	RTM1288F	Thrust Bearing	2
6	D20609F	Set Screw	1	12	RTM1291F	Wave Spring Washer	2

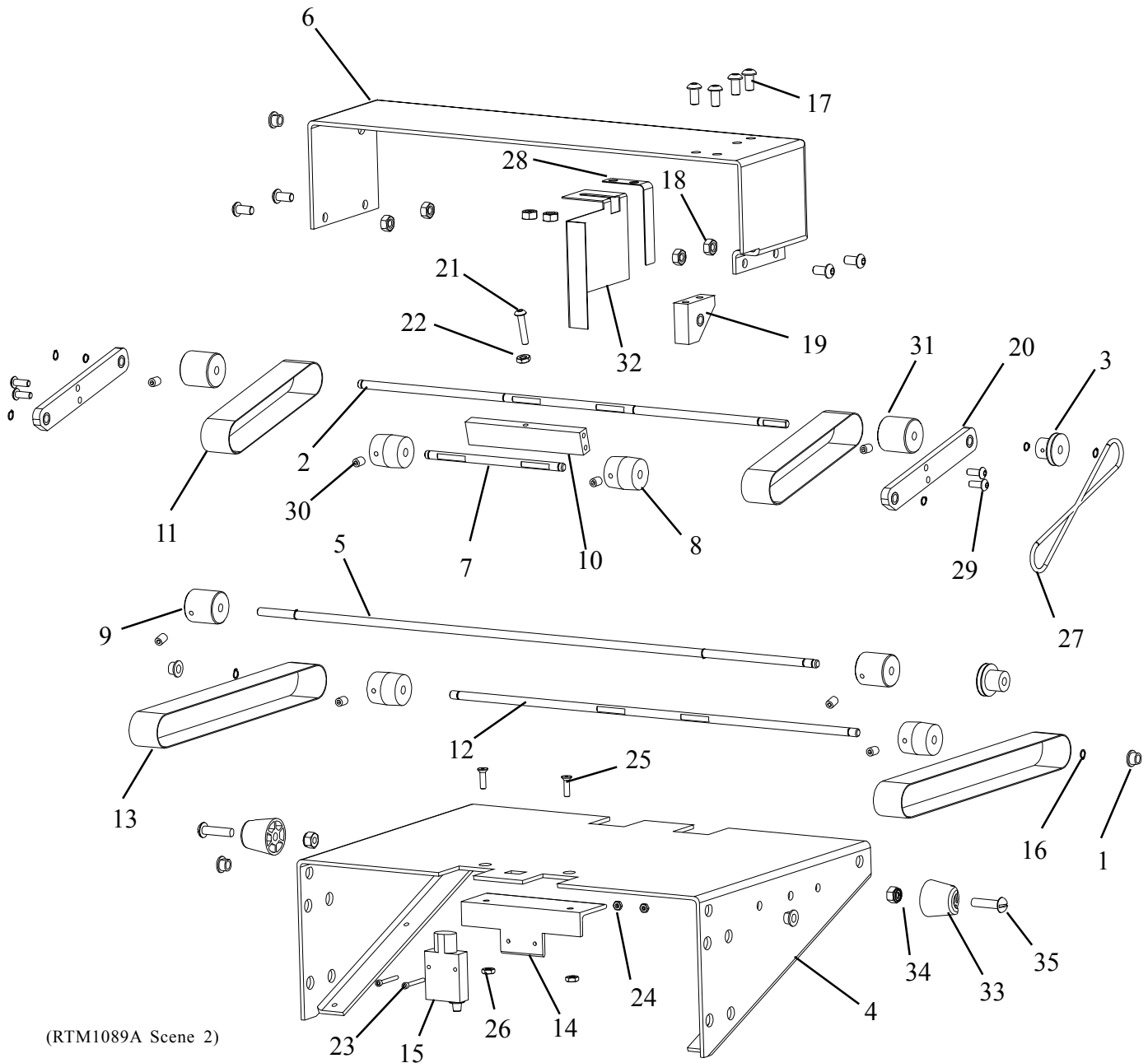

(RTM1089A Scene 2)

Index Number	Part Number	Part Name	Number Required	Index Number	Part Number	Part Name	Number Required
1	RTM1181F	Bearing, "D" Flange	5	20	RTM1242A	Support Assembly	2
2	RTM1082F	Shaft, Upper Drive	1	21	CG26B	Screw, 10-32 x 1.00 Button Hd	1
3	RTM1241F	Pulley, Round Belt	1	22	CB278	Nut, 10-32 Hex.	1
4	RTM1078F	Table, Lower Conveyor	1	*23	CB56G2	Screw, 4-40 x 1.00 Soc. Hd.	2
5	RTM1081F	Shaft, Lower Conveyor Drive	1	*24	CG13	Nut, 4-40 Hex.	2
6	RTM1080F	Cover, Upper Conveyor	1	25	CB206E	Screw, 8-32 x .625 Fl. Hd. Soc.	2
7	RTM1243F	Shaft, Upper Idler	1	26	CB719	Nut, 8-32 Hex.	2
8	RTM1052F	Pulley, Crowned Flat Belt	4	27	RTM1274F	Belt, Round	1
9	RTM1053F	Pullely, Flat Belt	2	28	RTM1276F	Separator, Round Belt	1
10	RTM1244F	Brace, Upper Cross	1	29	CG26A	Screw, 10-32 x .500 Button Hd.	4
11	RTM1087F	Belt, Upper Conveyor	2	30	CB59H	Screw, 8-32 x .375 Soc. Set	8
12	RTM1346F	Shaft, Lower Idler	1	31	RTM1343F	Pulley ø1.032, Flat Belt	2
13	RTM1088F	Belt, Lower Conveyor	2	32	RTM1344F	Guard, Belt	1
*14	RTM1338F	Bracket, Infeed Sensor Mount	1	33	RTM1345F	Bumper, Alignment	2
*15	RTM1336F	Sensor, Photoelectric	1	34	CB860C	Nut, Elastic Stop, .250-20	2
16	CB837C	Retaining Ring, ø.250 Shaft	10	35	RBM1252F	Screw, .250-20 x 1.00, Rd. Hd.	2
17	CG26F	Screw, .250-20 Button Head	8				
18	CB493	Nut, .250-20 Hex.	6				
19	RTM1236A	Block Assembly	1				

* When replacing original sensors and/or mounting bracketry on models prior to serial number 1050, order sensor update kit CBBB3000E7.

Trimmer

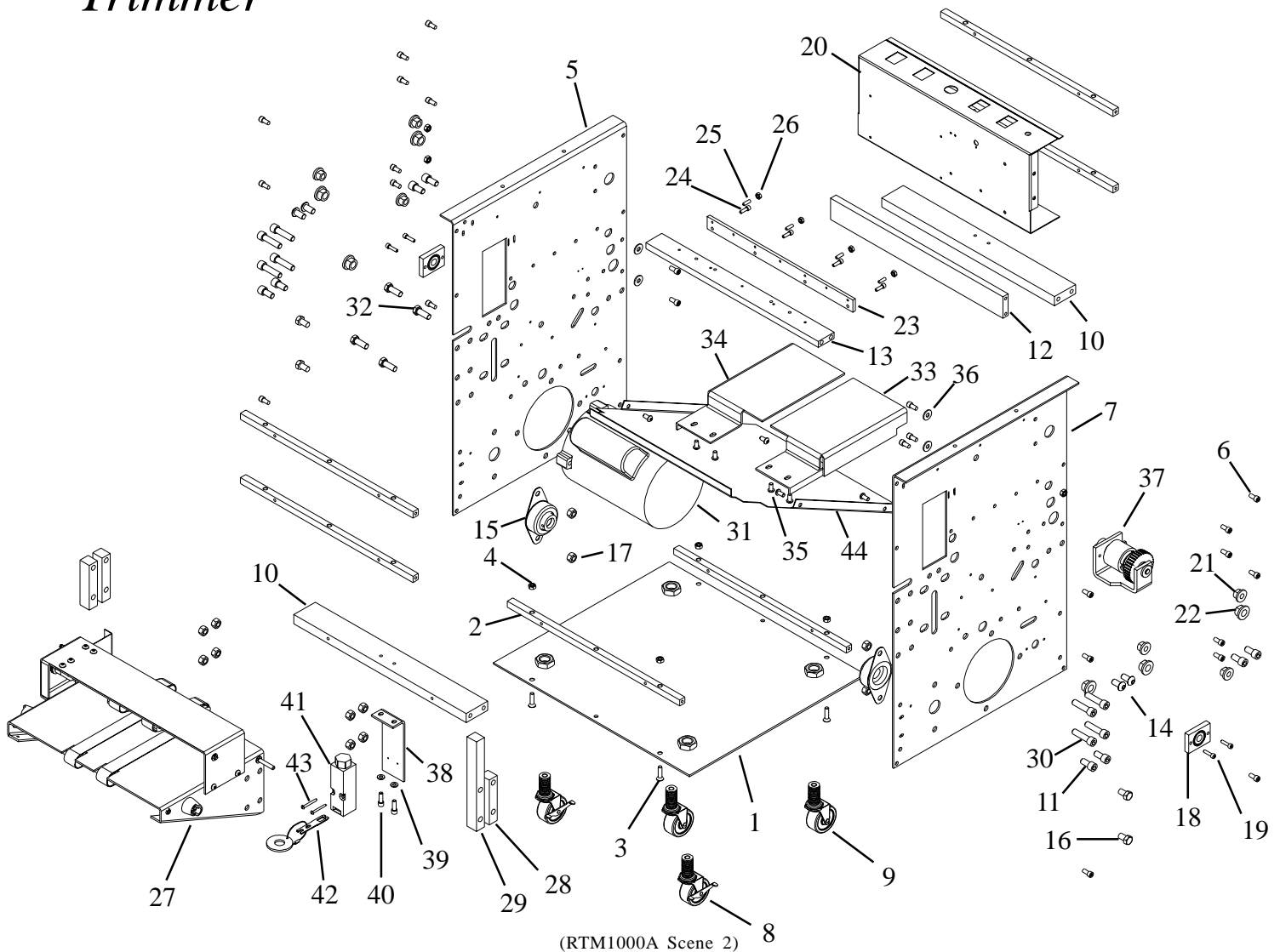

(RTM1000A Scene 2)

Index Number	Part Number	Part Name	Number Required	Index Number	Part Number	Part Name	Number Required
1	RTM1111F	Plate, Base	1	23	RTM1006F	Bar, Lower Knife Adjustment	1
2	RTM1062F	Tie Bar	6	24	CB154A	Screw, 10-24 x .625 Soc. Hd.	4
3	RTM1284F	Screw, .250-20 x 1.00 Fl. Hd.	4	25	RTM1293F	Screw, 10-24 x .625 Set, Fl. Pt.	4
4	CB493	Nut, .250-20 Hex.	7	26	D3797F	Nut, 10-24 Hex.	4
5	RTM1113F	Plate, L.H. Side	1	27	RTM1089A	Infeed Conveyor Assembly	1
6	CB325	Screw, .250-20 x .500 Soc. Hd.	25	28	RTM1248F	Spacer, Short	3
7	RTM1112F	Plate, R.H. Side	1	29	RTM1257F	Spacer, Long	1
8	RTM1282A	Caster Assembly w/Brake	2	30	CB617	Screw, .375-16 x 1.50 Soc. Hd.	8
9	RTM1283A	Caster Assembly w/o Brake	2	31	RTM1161F	Motor	1
10	RTM1095F	Tie Bar, Main	2	32	D25947F	Screw, .375-16 x 1.00 Hex. Hd.	4
11	CB314A	Screw, .375-16 x .75 Soc. Hd.	8	33	RTM1031A	Table, R.H.	1
12	RTM1233F	Bracket, Inner Table Support	1	34	RTM1032A	Table, L.H.	1
13	RTM1005F	Support, Lower Knife	1	35	CG26F	Screw, .250-20 x .50 Button Hd.	4
14	RTM1280F	Screw, .375-16 x .75 Button Hd.	4	36	CB718	Washer, Flat	4
15	RTM1011F	Bearing, Flange Ball	2	37	RTM1286A	Clutch Assembly, Discharge	1
16	CB328	Screw, .375-16 x .75 Hex.	4	38	RTM1314F	Bracket, Interlock Switch	1
17	D30541F	Nut, .375-16 Hex.	12	39	CB806	Washer, .250 Flat	2
18	RTM1141A	Assembly, Bearing	2	40	CB51	Screw, .250-20 x .75 Soc. Hd.	2
19	CB651A	Screw, 10-24 x .75 Soc. Hd.	4	41	RTM1326F	Switch, Interlock	1
20	RTM1114A	Power Panel Assembly	1	42	RTM1327A	Key Assembly, Interlock	1
21	RTM1173F	Bearing, "D" Flange, ϕ .375 I.D.	6	43	RTM1324F	Screw, 6-32 x 1.25 Button Hd.	2
22	RTM1157F	Bearing, "D" Flange, ϕ .500 I.D.	6	44	RTM1061F	Trimmings Chute	1

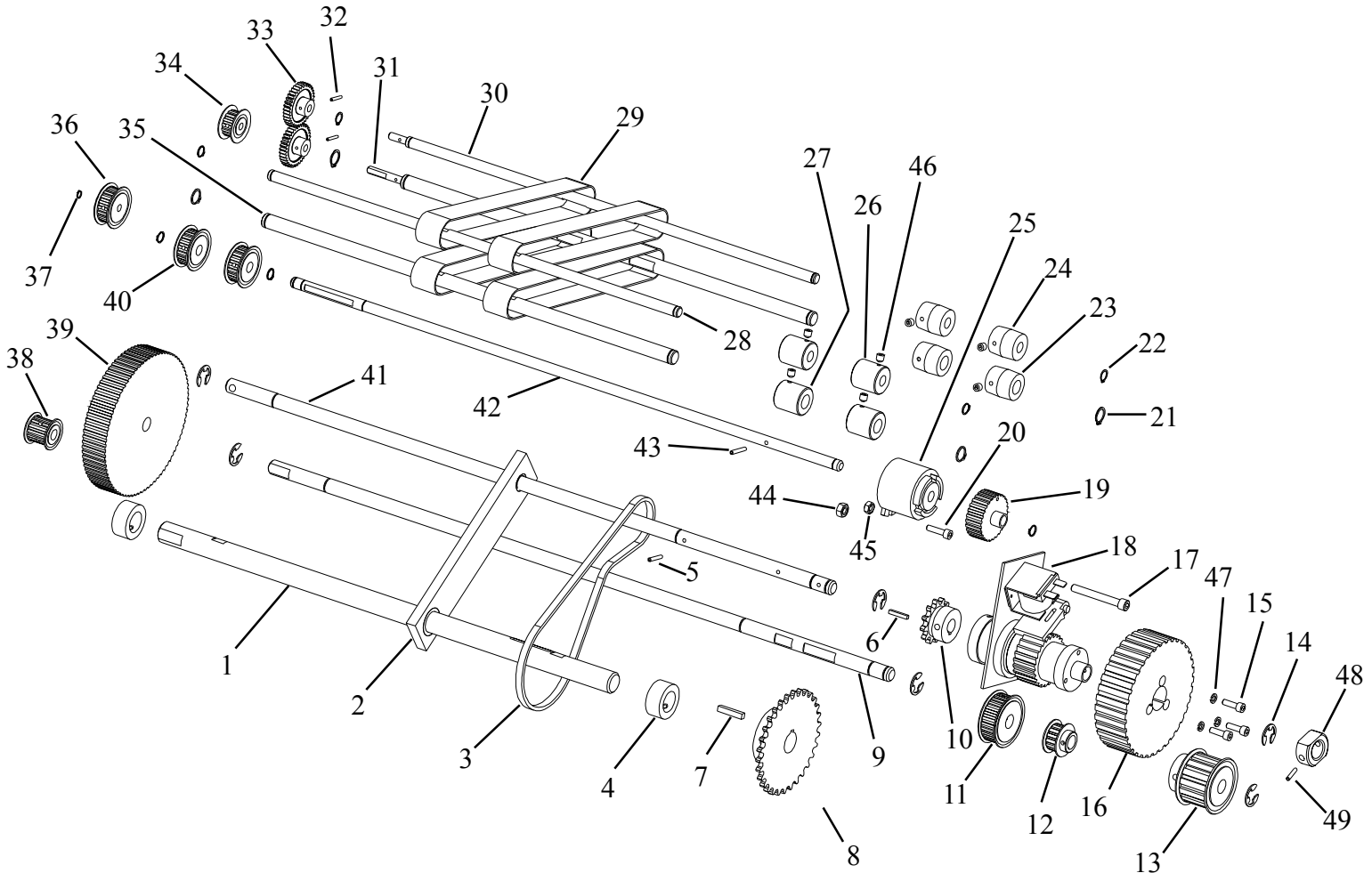

(RTM1000B Scene 5)

Index Number	Part Number	Part Name	Number Required	Index Number	Part Number	Part Name	Number Required
1	RTM1012F	Shaft, Pull Down Drive	1	27	RTM1138F	Pulley, Flat, ø.500 Bore	2
2	RTM1269A	Support, Knife Shaft	1	28	RTM1253F	Shaft	1
3	RTM1351F	Roller Chain	1	29	RTM1088F	Belt, Endless Table	4
4	RTM1287F	Locking Collar	2	30	RTM1050F	Shaft, Upper Conveyor Drive	1
5	D29845F	Roll Pin, .125 x .750	1	31	RTM1049F	Shaft, Conveyor Drive	1
6	RTM1285F	Key, .125 Sq. x .750	1	32	CB835F2	Roll Pin, .093 x .625	2
7	RTM1158F	Key, .3125 Sq. x 1.000	1	33	RTM1258F	Gear, Spur	2
*8	RTM1350F	Sprocket, 35T Driven	1	34	RTM1048F	Pulley, 15XL Timing	1
9	RTM1036F	Shaft, Reduction	1	35	RTM1051F	Shaft, Conveyor Driven	1
*10	RTM1342F	Sprocket, 12 Teeth, Drive	1	36	RTM1143F	Pulley, 18XL Timing	1
11	RTM1041F	Pulley, 27XL Timing	1	37	CB837C	Retaining Ring, ø.250 Shaft	2
12	RTM1267F	Pulley 15XL Timing	1	38	RTM1034F	Pulley, 14XL Timing	1
13	RTM1038F	Pulley, 15L Timing	1	39	RTM1035F	Pulley, 80XL Timing	1
14	RTM1281F	E-Ring, Retaining, ø.500	12	40	RTM1037F	Pulley, 20XL Timing	2
15	CB154	Screw, 10-32 x .625 Soc. Hd.	3	41	RTM1094F	Shaft, Knife Clutch	1
16	RTM1120F	Pulley, 36L Timing	1	42	RTM1043F	Shaft, Infeed Clutch	1
17	CB629D	Screw, .250-20 x 2.0 Soc. Hd.	1	43	D23940F	Roll Pin, .125 x .875	1
18	RTM1093F	Clutch, Wrap Spring w/Brake	1	44	CB493	Nut, .250-20 Hex.	1
19	RTM1039A	Pulley Assembly, 27XL	1	45	D3797F	Nut, 10-24 Hex.	1
20	CB651A	Screw, 10-24 x .75 Soc. Hd.	1	46	CB59D	Screw, .250-20 x .25 Soc. Set	8
21	CB837E	Retaining Ring, ø.500 Shaft	7	47	CB371	Lockwasher, No. 10	3
22	CB837B	Retaining Ring, ø.375 Shaft	8	48	RTM1349F	Collar, Manual Cycle	1
23	RTM1135F	Pulley, Crowned, ø.500 Bore	2	49	CB835E	Roll Pin, 3/16 Diamx1	1
24	RTM1234F	Pulley, Crowned, ø.375 Bore	2				
25	RTM1042F	Clutch Wrap Spring	1				
26	RTM1235F	Pulley, Flat, ø.375 Bore	2				

* When replacing original 35 or 12 tooth sprocket on models prior to serial number 1050, you must replace **BOTH** at the same time with the indicated items 8 and 10.

Trimmer

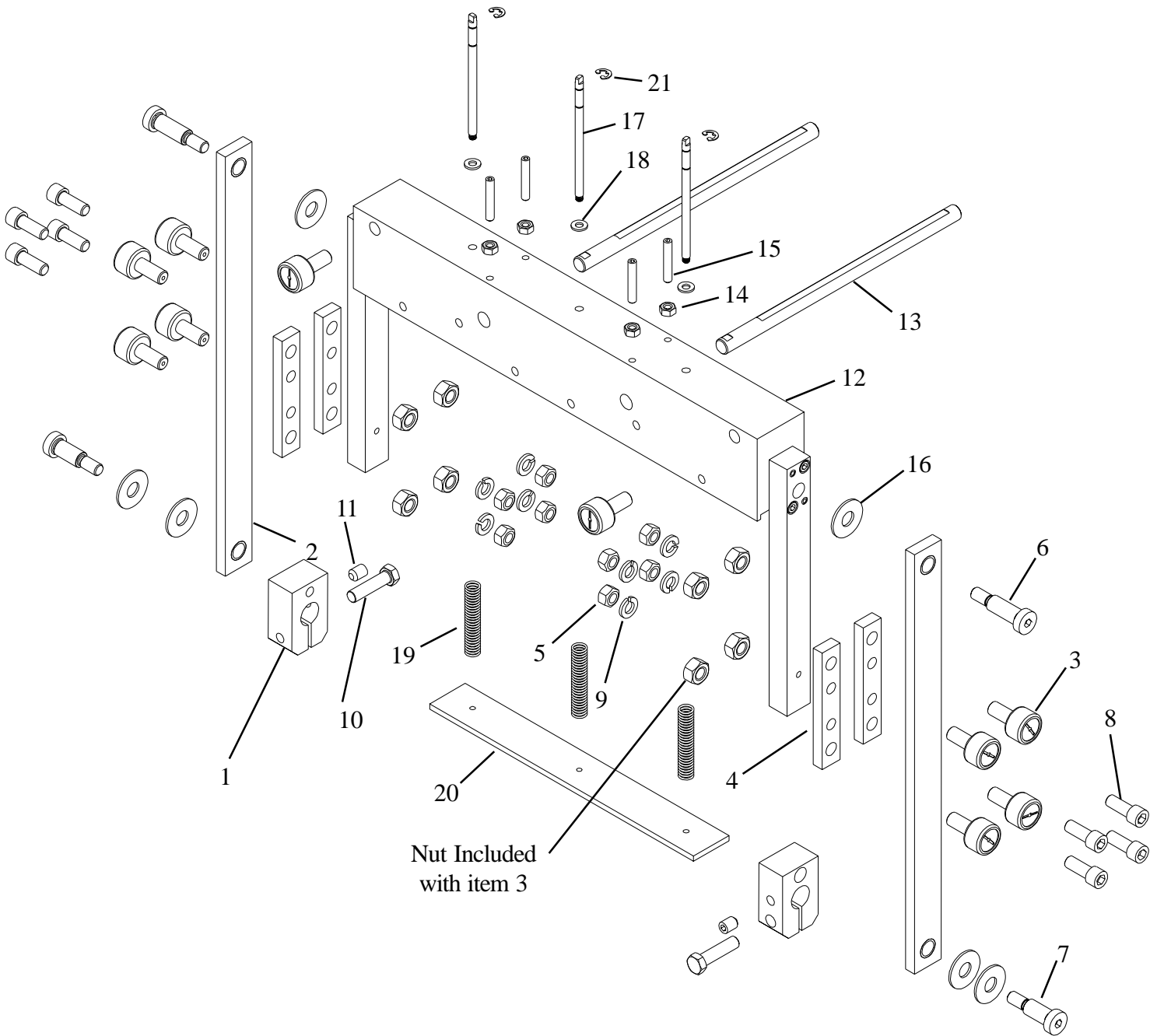

(RTM1000C Scene 1)

Index Number	Part Number	Part Name	Number Required	Index Number	Part Number	Part Name	Number Required
1	RTM1010F	Block, Rotator	2	12	RTM1002A	Knife Bar Assembly	1
2	RTM1009A	Bar, Pull Down	2	13	RTM1020F	Shaft, Backgage	2
3	RTM1008F	Roller, Stud	10	14	CB493	Nut, .250-20 Hex.	4
4	RTM1007F	Mount, Roller	4	15	CB1051A	Screw, .250-20 x 1.50 Set	4
5	D30541F	Nut, .375-16 Hex.	8	16	CB198	Washer, Flat	6
6	RTM1207F	Screw, .500 x 1.25 Shoulder	2	17	RTM1014F	Rod, Clamp	3
7	RTM1213F	Screw, .500 x 1.00 Shoulder	2	18	CB806	Washer, ø.250 I.D. Flat	3
8	CB314	Screw, .375-16 x 1.00 Hex.	8	19	RTM1193F	Compression Spring	3
9	CB889	Lockwasher, .375	8	20	RTM1013F	Plate, Front Clamp	1
10	CB375A	Screw, .375-16 x 1.500 Hex.	2	21	RTM1251F	E-Ring, Retaining, ø.250 Shaft 3	
11	CB377	Screw, .375-16 x .500 Set	2				

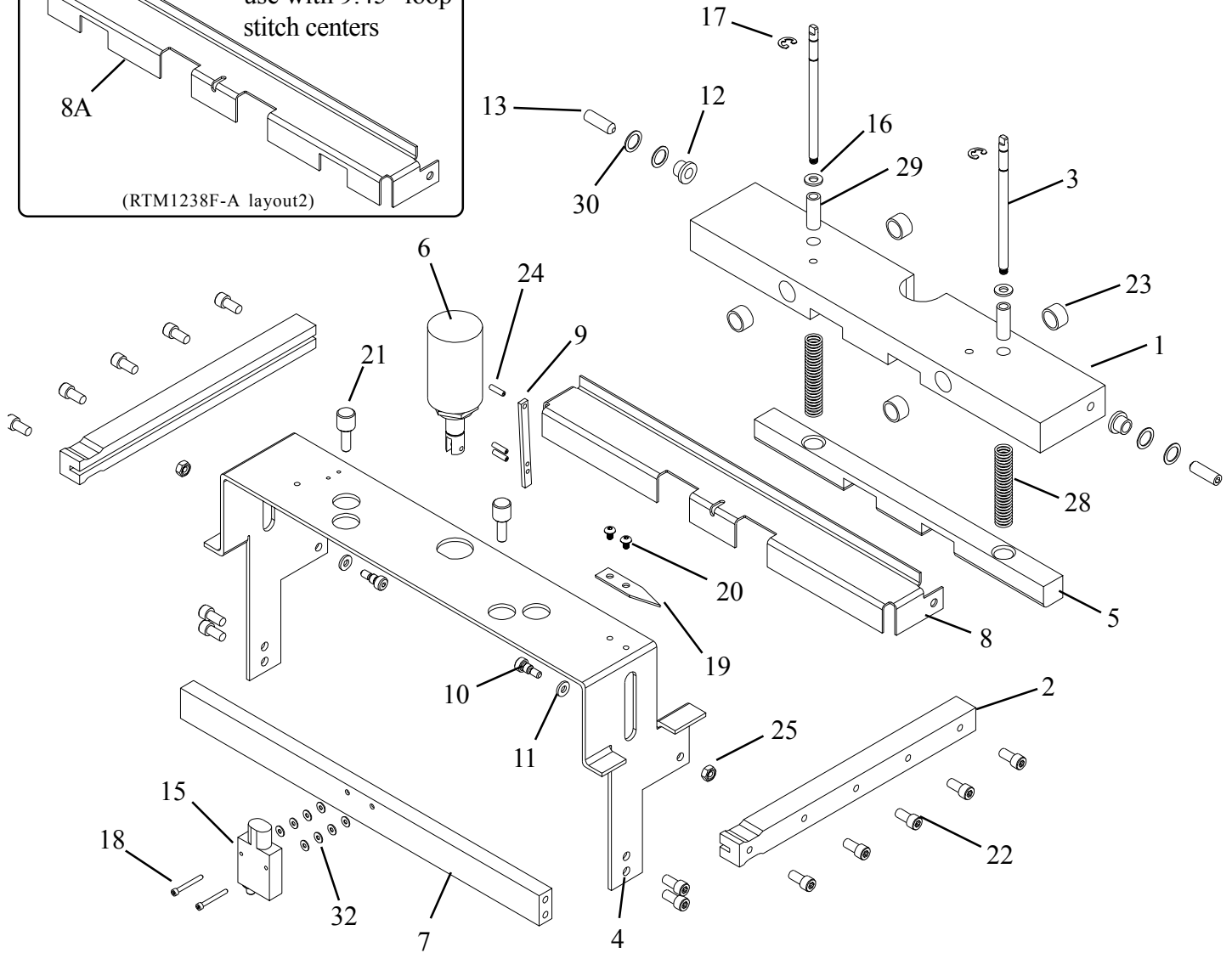
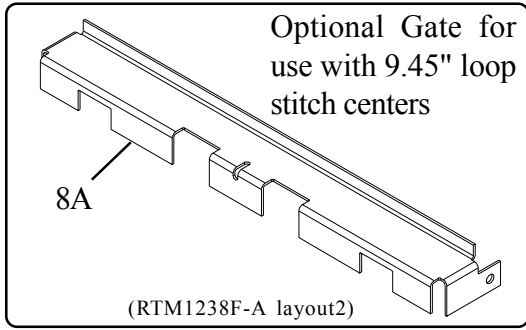

(RTM1000C Scene 3)

Index Number	Part Number	Part Name	Number Required	Index Number	Part Number	Part Name	Number Required
1	RTM1022F	Carriage, Backgage	1	16	CB806	Washer, ø.250 I.D. Flat	2
2	RTM1230F	Rail	1	17	RTM1251F	E-Ring, Retaining, ø.250 Shaft	2
3	RTM1014F	Rod, Clamp	2	*18	CB56G2	Screw, 4-40 x 1.0 Soc. Hd.	2
4	RTM1231F	Bracket, Gate Support	1	19	RTM1255F	Pointer, Backgage Position	1
*5	RTM1339F	Clamp, Gate	1	20	CG26L	Screw, 8-32 x .25 Button Hd.	2
6	RTM1023F	Solenoid	1	21	RTM1033F	Knob, Carriage Lock	2
*7	RTM1337F	Brace, Gate Sensor	1	22	CB325	Screw, .250-20 x .625 Soc. Hd.	14
8	RTM1238F	Gate	1	23	RTM1189F	Bearing, Sleeve, .50x.625x.375	4
8A	RTM1238F-A	Gate, 4 Head Loop Stitch Option	1	24	CB835M2	Pin, .125 x .500 Roll	3
9	RTM1240F	Link, Gate	1	25	D3797F	Nut, 6-32 Hex.	2
10	CB1421E	Screw, ø.250 Shoulder	2	28	RTM1192F	Spring, Compression	2
11	CB1262	Washer, ø.203 I.D. Flat	2	29	RTM1188F	Bearing, Sleeve	2
12	RTM1245F	Bearing, Flanged	2	30	RTM1307F	Washer, Flat	4
13	CB890	Screw, .312-18 x 1.00 Fl. Pt. Soc. Set.	2	*32	CP74	Washer, No. 4, Flat	8
*15	RTM1336F	Sensor, Photoelectric	1				

* When replacing original sensors and/or mounting bracketry on models prior to serial number 1050, order sensor update kit CBBB3000E7.

Trimmer

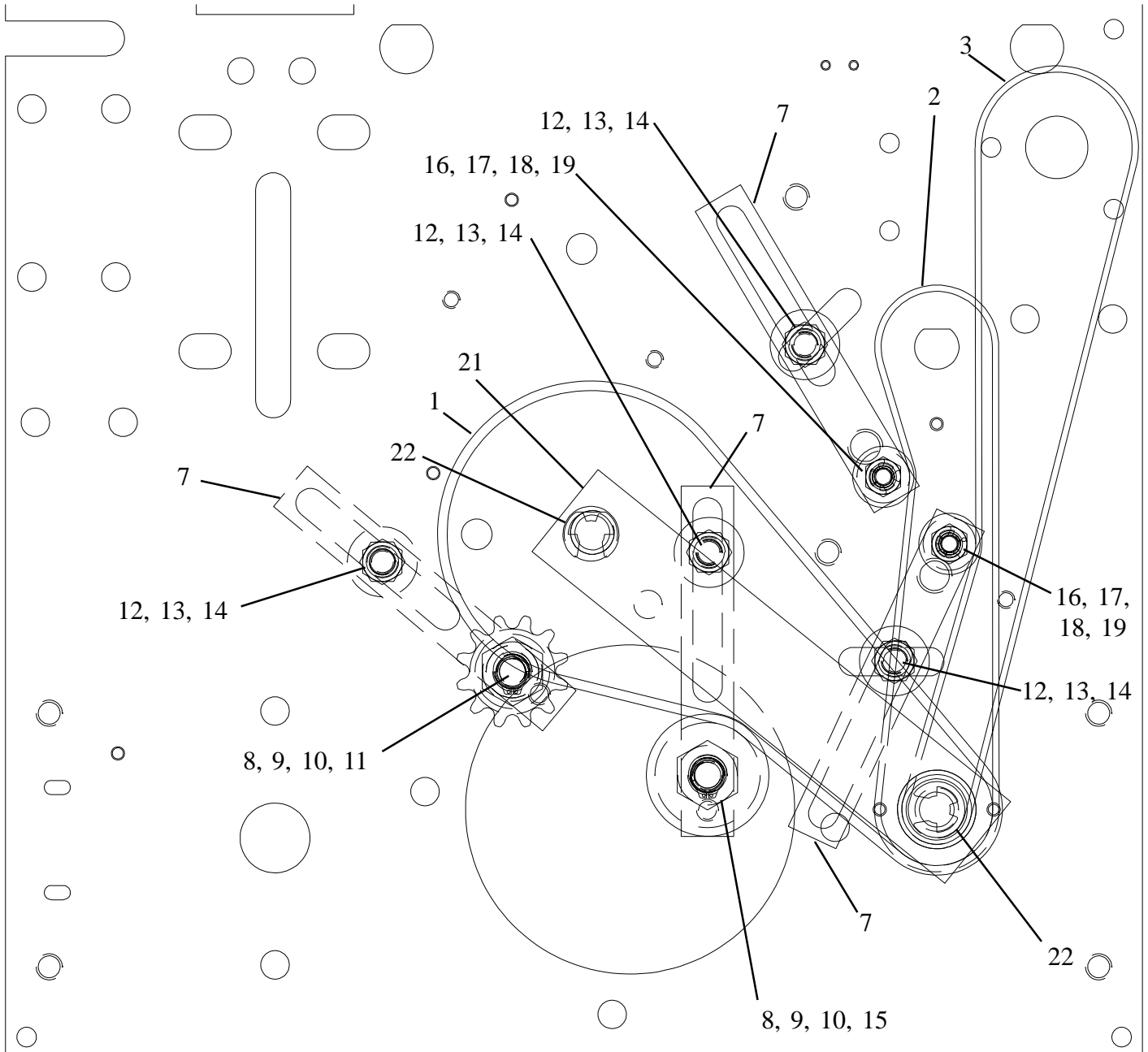

(RTM1000B Scene 3)

Index Number	Part Number	Part Name	Number Required	Index Number	Part Number	Part Name	Number Required
1	RTM1155F	Belt, Timing	1	14	D30541F	Nut, .375-16 Hex.	7
2	RTM1216F	Belt, Timing	1	15	RTM1145F	Pulley, Idler	1
3	RTM1275F	Belt, Timing	1	16	RTM1279F	Shaft, Idler	2
4	RTM1167F	Belt, Timing	1	17	CB102	Nut, .312-18 Hex.	5
5	RTM1106F	Belt, Timing	1	18	RTM1278F	E-Ring, Retaining, ϕ .312	10
6	RTM1104F	Belt, Timing	1	19	RTM1208F	Pulley, Idler	5
7	RTM1119F	Block, Idler	7	20	RTM1044F	Shaft, Idler	3
8	RTM1144F	Shaft, Idler	2	21	RTM1124A	Tie Bar Assembly	1
9	CB145A	Nut	2	22	RTM1281F	E-Ring, Retaining, ϕ .500 shaft	2
10	CB837E	Retaining Ring	3	23	RTM1247A	Tie Bar Assembly	1
11	RTM1139F	Idler, Chain	1	24	CB837B	Retaining Ring, ϕ .375 shaft	1
12	CB375	Screw, .375-16x1.25 Hex. Hd.	7	25	CB837C	Retaining Ring, ϕ .250 shaft	1
13	CB179	Washer, .375 Flat	9				

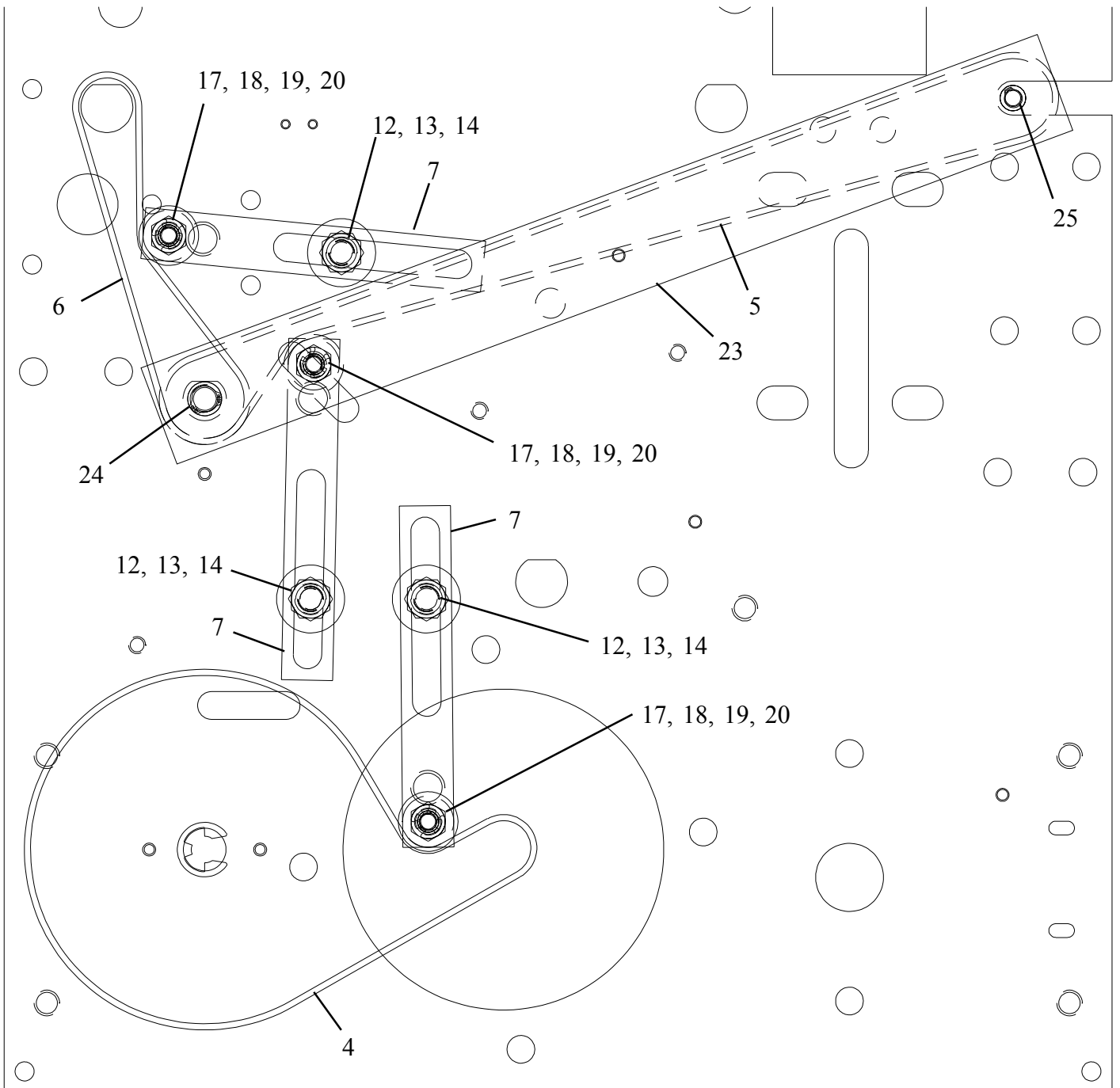

(RTM1000B Scene 6)

Trimmer

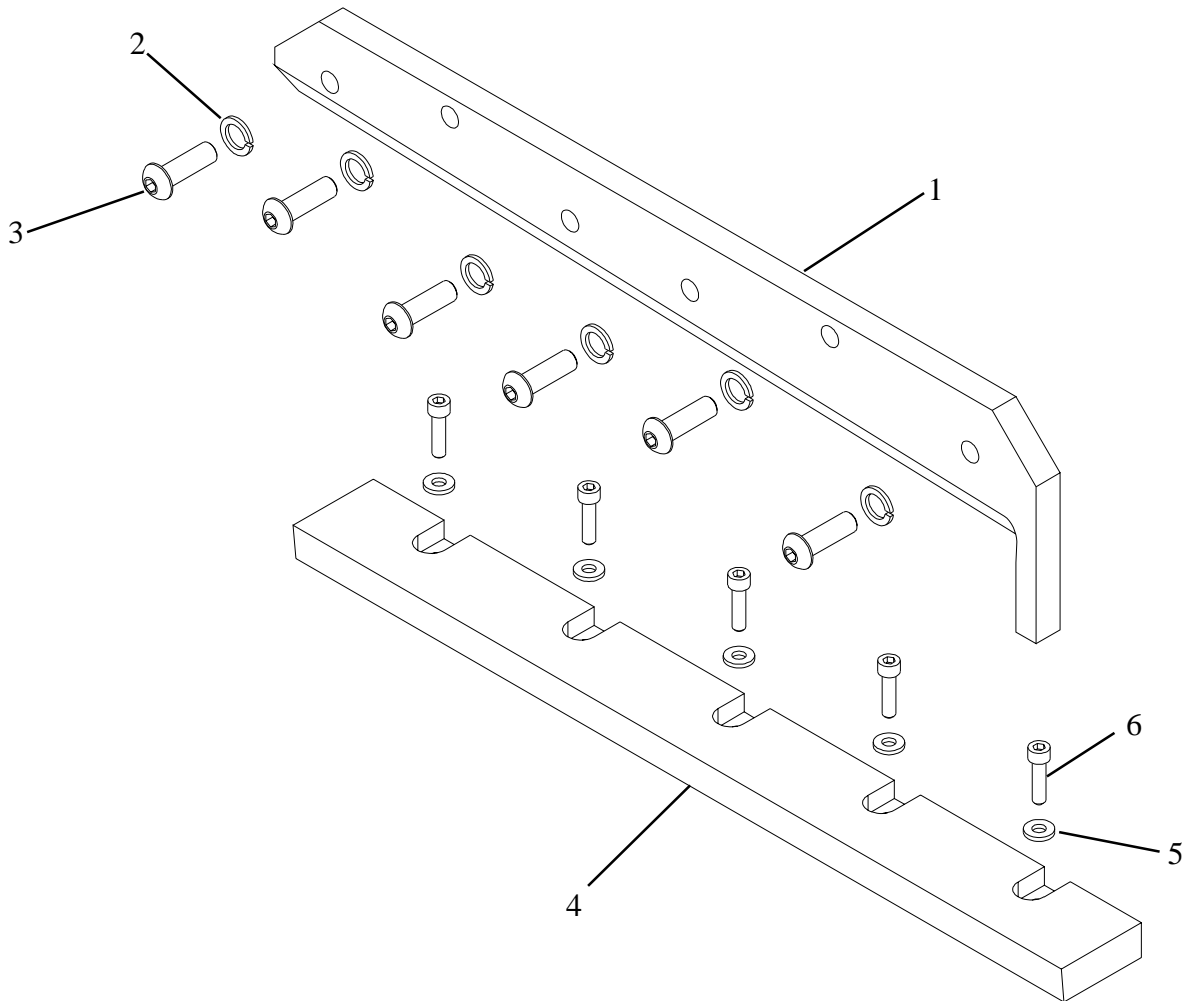

(RTM1000C Scene 6)

Index Number	Part Number	Part Name	Number Required	Index Number	Part Number	Part Name	Number Required
1	RTM1003F	Upper Knife	1	4	RTM1004F	Lower Knife	1
2	CB371B	Washer, ϕ .437 Lock	6	5	CB1262	Washer, No. 10 Flat	5
3	RTM1309F	Screw, .312-24x1.00 Button Hd. 6	6	6	CB651A	Screw, 10-24 x .75 Soc. Hd.	5

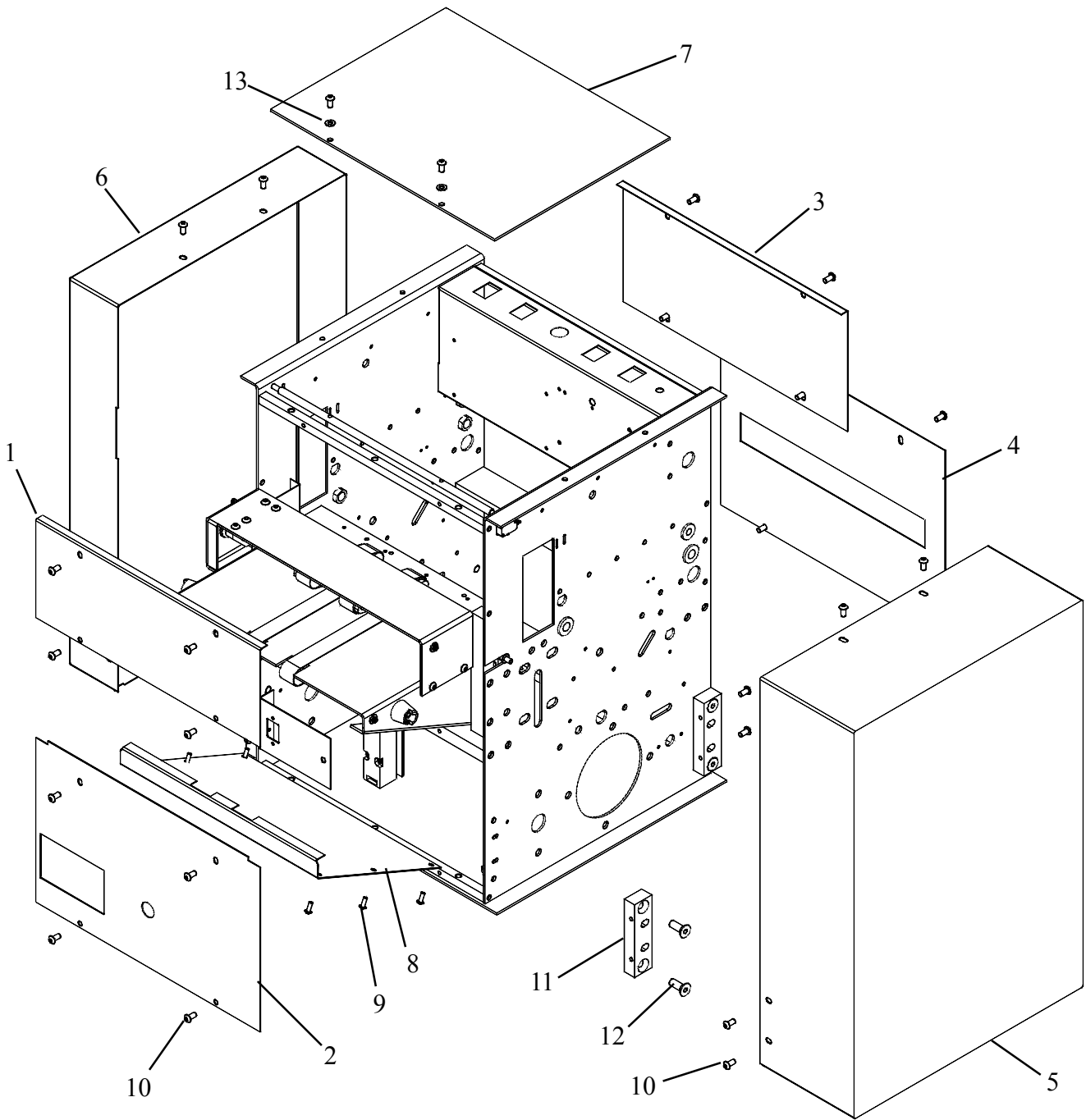

(RTM1000D Scene 3)

Index Number	Part Number	Part Name	Number Required	Index Number	Part Number	Part Name	Number Required
1	RTM1118F	Cover, Upper Front	1	8	RTM1077F	Cover, Lower Infeed	1
2	RTM1117F	Cover, Lower Front	1	9	CG26A	Screw, .10-32x.500 Button Hd.	6
3	RTM1105F	Cover, Upper Rear	1	10	CG26F	Screw, .250-20x.500 Button Hd.	22
4	RTM1103F	Cover, Lower Rear	1	11	RTM1312F	Brace, Cover	4
5	RTM1101F	Cover, R.H. Side	1	12	CB189D	Screw, .375-16x1.00 Fl. Soc.	8
6	RTM1102F	Cover, L.H. Side	1	13	CB806	Washer, Flat	2
7	RTM1099F	Cover, Top	1				

WIRING HARNESS AND COMPONENT CONNECTIONS

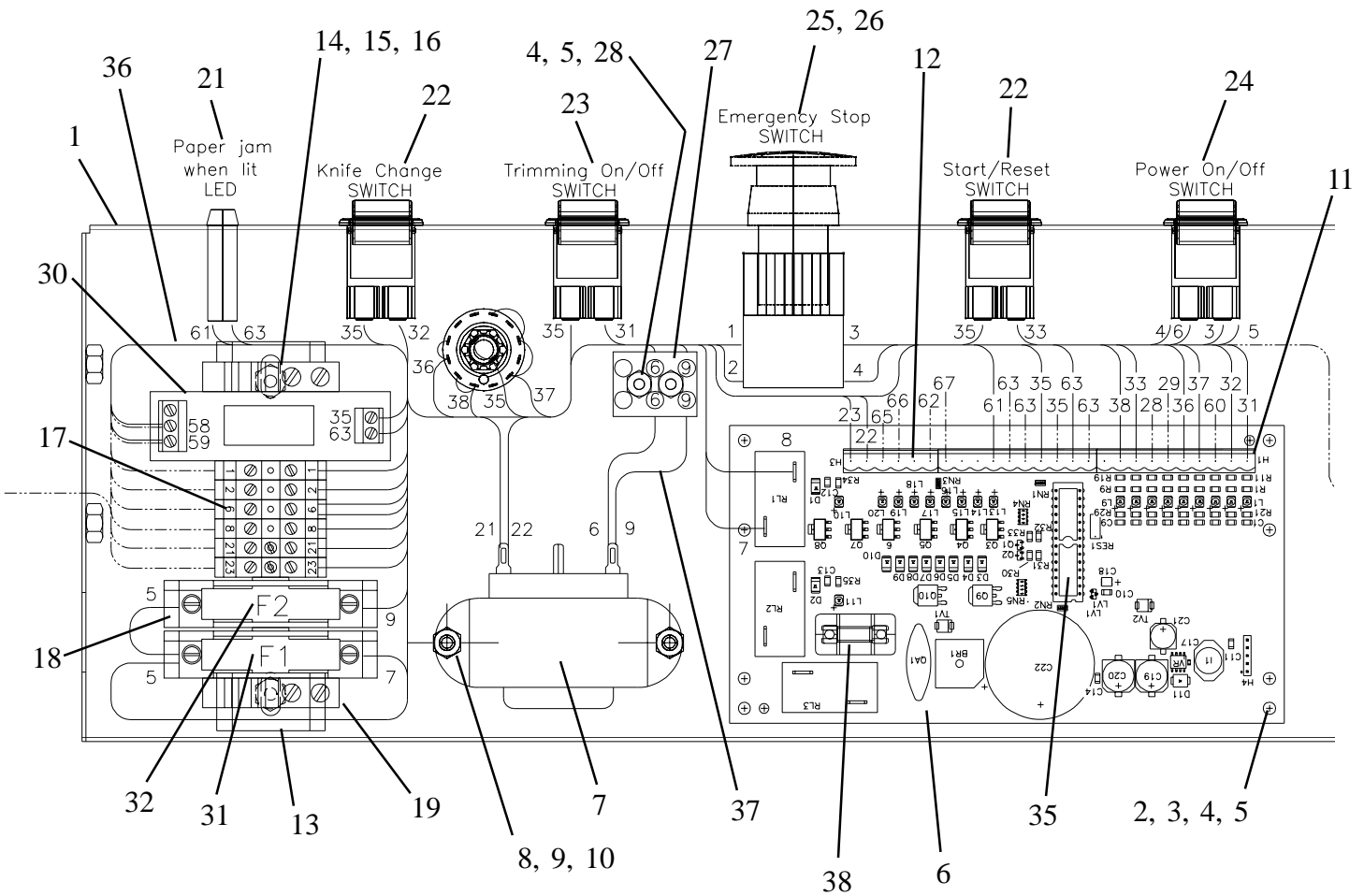
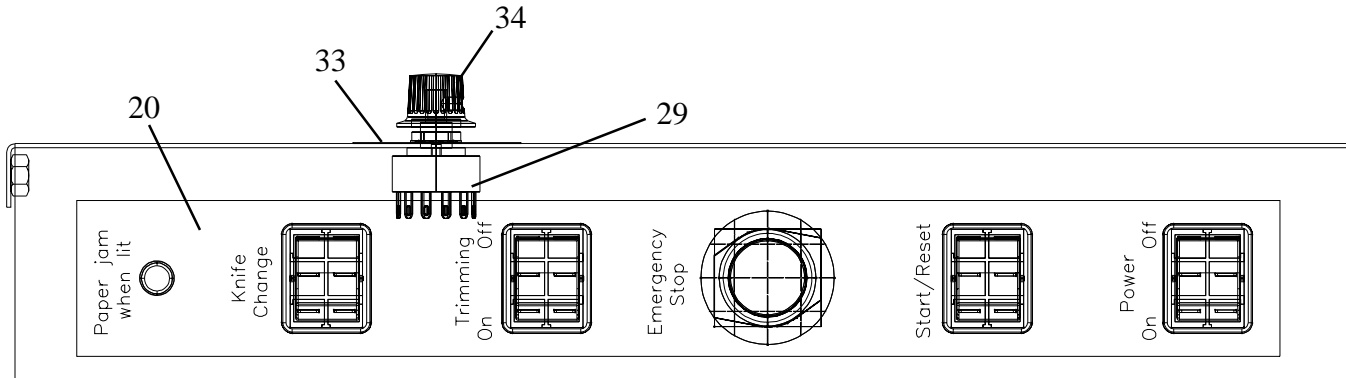

——— Solid wires are part of harness assembly
 - - - - - Phantom wires are external wires entering panel box.

115Vac Connections

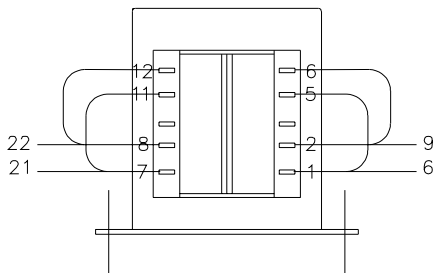

230Vac Connections

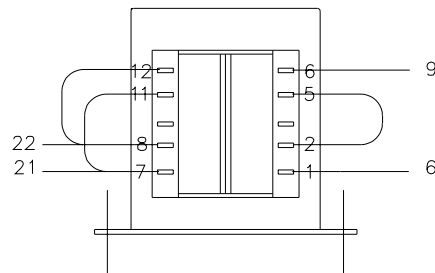

Index Number	Part Number	Part Name	Number Required	Index Number	Part Number	Part Name	Number Required
1	RTM1114F	Power Panel	1	24	RTM1169F	On/Off Rocker Switch (115Vac)	1
2	RTM1171F	Stand Off	4		RTM1331F	On/Off Rocker Switch (230Vac)	1
3	RTM1176F	Screw 6-32 x .25 (stand off)	4	25	RBM1491F	Emergency Stop	1
4	CK50	Lockwasher, No. 6	8	26	RBM1492F	Contact Block	1
5	CB720	Nut, 6-32 Nex.	6	27	RBM1240F	Terminal Block	1
6	RTM1172A	Printed Circuit Board	1	28	RTM1219F	Screw, 6-32 x .75 Button Hd.	2
7	RTM1170F	Transformer	1	*29	RTM1311A2	Rotary Switch	1
8	CG26N	Screw, 8-32x.375 (transformer)	2	30	RTM1294F	Relay Module	1
9	CB988A	Lockwasher, No. 8	2	31	RTM1303F	Fuse, 6A, Time Delay (115Vac)	1
10	CB719	Nut, 8-32 Hex.	2		RTM1330F	Fuse, 3A, Time Delay (230Vac)	1
11	RTM1217F	Plug, PCB, 10 Pin	2	32	RTM1302F	Fuse, 1A, Time Delay (115Vac)	1
12	RTM1218F	Plug, PCB, 6 Pin	1		RTM1329F	Fuse, .5A, Time Delay (230Vac)	1
13	RTM1199F	Rail, Terminal Block	1	*33	RTM1306F2	Decal, Belt Drive	1
14	CG26K	Screw, 10-32 x .25 Button Hd.	2	34	RBM1419F	Knob	1
15	CB278	Nut, 10-32 Hex.	2	*35	RTM1295F8	Microchip	1
16	CB988	Washer, No. 10	2	36	RTM1304F	Wire Harness	1
17	RTM1196F	Terminal Block	6	37	RTM1328F	Wire Assembly	2
18	RTM1202F	Fuse Block Terminal	2	38	RTM1333F	Fuse, 2A, Time-lag	1
19	RTM1197F	Terminal End Bracket	2				
20	RTM1168F	Decal, Controls	1				
21	RTM1162F	Indicator Assembly, LED	1				
22	CG137	Rocker Switch	2				
23	CG138	Rocker Switch	1				

* When replacing original switch or microchip on models prior to serial number 1050, you must replace switch, decal, and microchip.

Trimmer

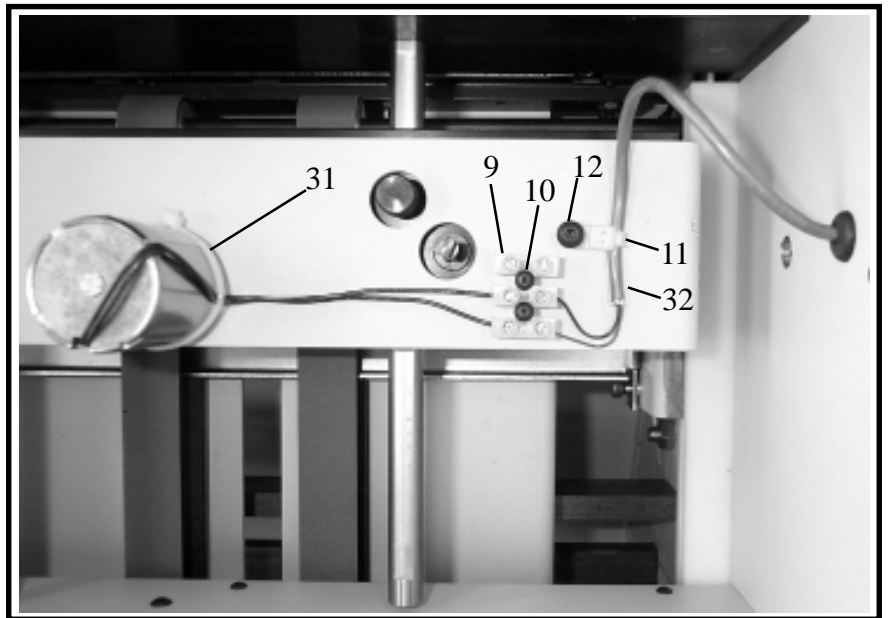
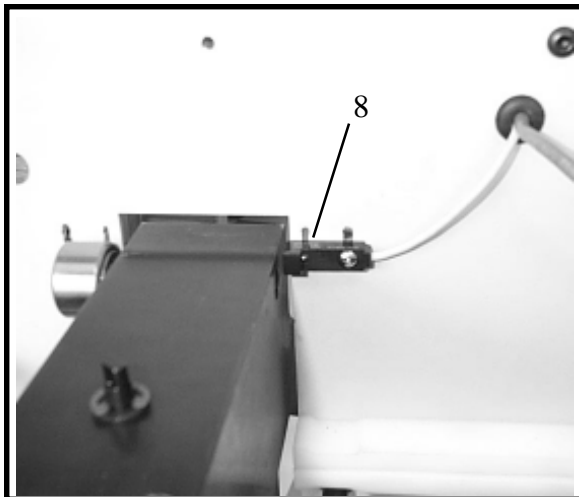
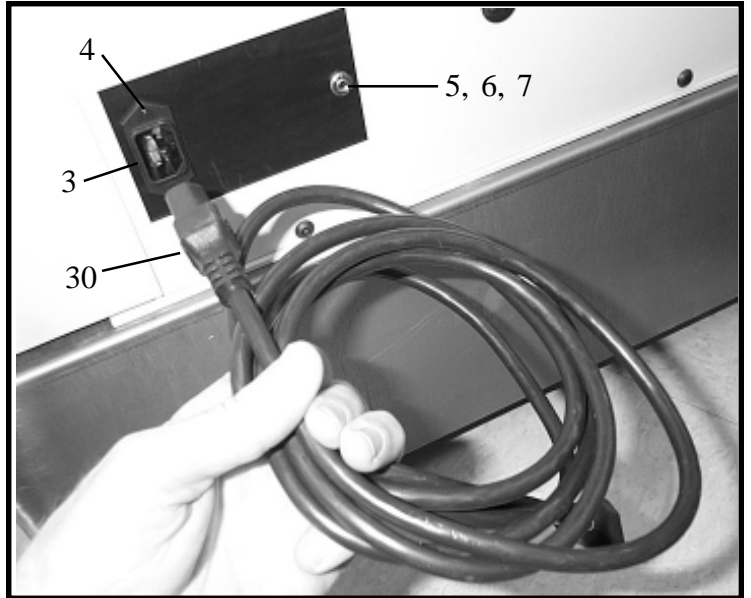
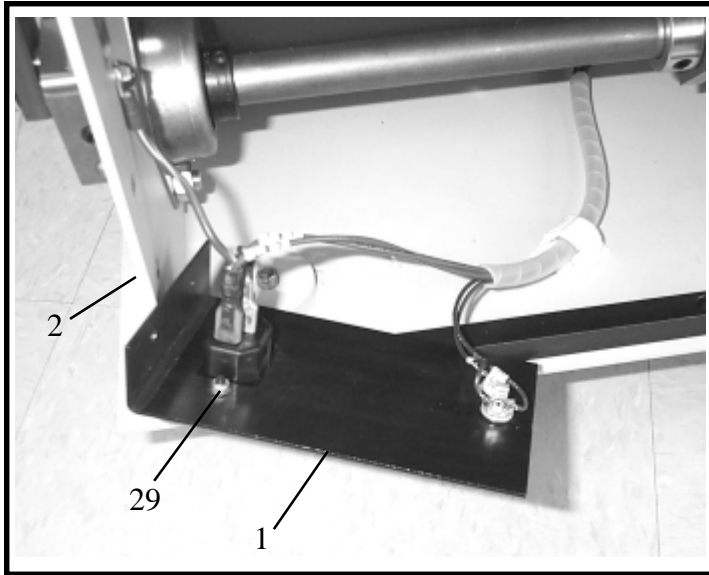

Index Number	Part Number	Part Name	Number Required	Index Number	Part Number	Part Name	Number Required
1	RBM1668F	Bracket, Power Cord	1	17	RTM1308F	Grommet	3
2	RBM1323G	Screw, 8-32 x .500 Pan Hd.	2	18	RTM1097F	Hinge, Hood	1
3	RBM1495F	Inlet, Power	1	19	CB837C	Retaining Ring, ø.250 Shaft	1
4	CB808	Screw, 5-40 x .375 Flat Hd.	2	20	RTM1098F	Cam, Hood Switch	1
5	CG190B	Phone Jack, ø.141 Plug	1	21	D31028F	Screw, 6-32 x .25 Set	1
6	CK164B	Washer, Flat Phenolic, ø.141	1	22	RTM1184F	Switch, Hood Micro	1
7	CK164	Washer, Swedged Fibre, ø.145	1	23	CB56R	Screw, 4-40 x .75 Soc. Hd.	2
8	RTM1186F	Sensor, Proximity (Screw, Washer, Nut Included)	1	24	CP74	Washer, No. 4 Flat	2
9	RBM1240F	Terminal Block	2	25	CG13	Nut, 4-40 Hex.	2
10	RTM1219F	Screw, 6-32 x .750 Button Hd.	2	26	CG195	Spiral Wrap	as req'd.
11	RTM1227F	Tyrap, No. 10 Screw Mount	10	27	RTM1304	Harness, Wire	1
12	CG26	Screw, 10-32 x .375 Button Hd.	1	28	CG179	Cord Retainer	6
13	CG26C	Screw, 10-32 x .75 Button Hd.	1	29	D27398F	Nut, 5-40 Hex.	2
14	CB1262	Washer, No. 10 Flat	7	30	RBM1353F	Power Cord (115Vac)	1
15	CB278	Nut, 10-32 Hex.	5		RBM1354F	Power Cord (230Vac)	1
16	RBM1428F	Grommet	2	31	RBM1817F	Tyrap	1
				32	EF1323F	Cable	3ft.

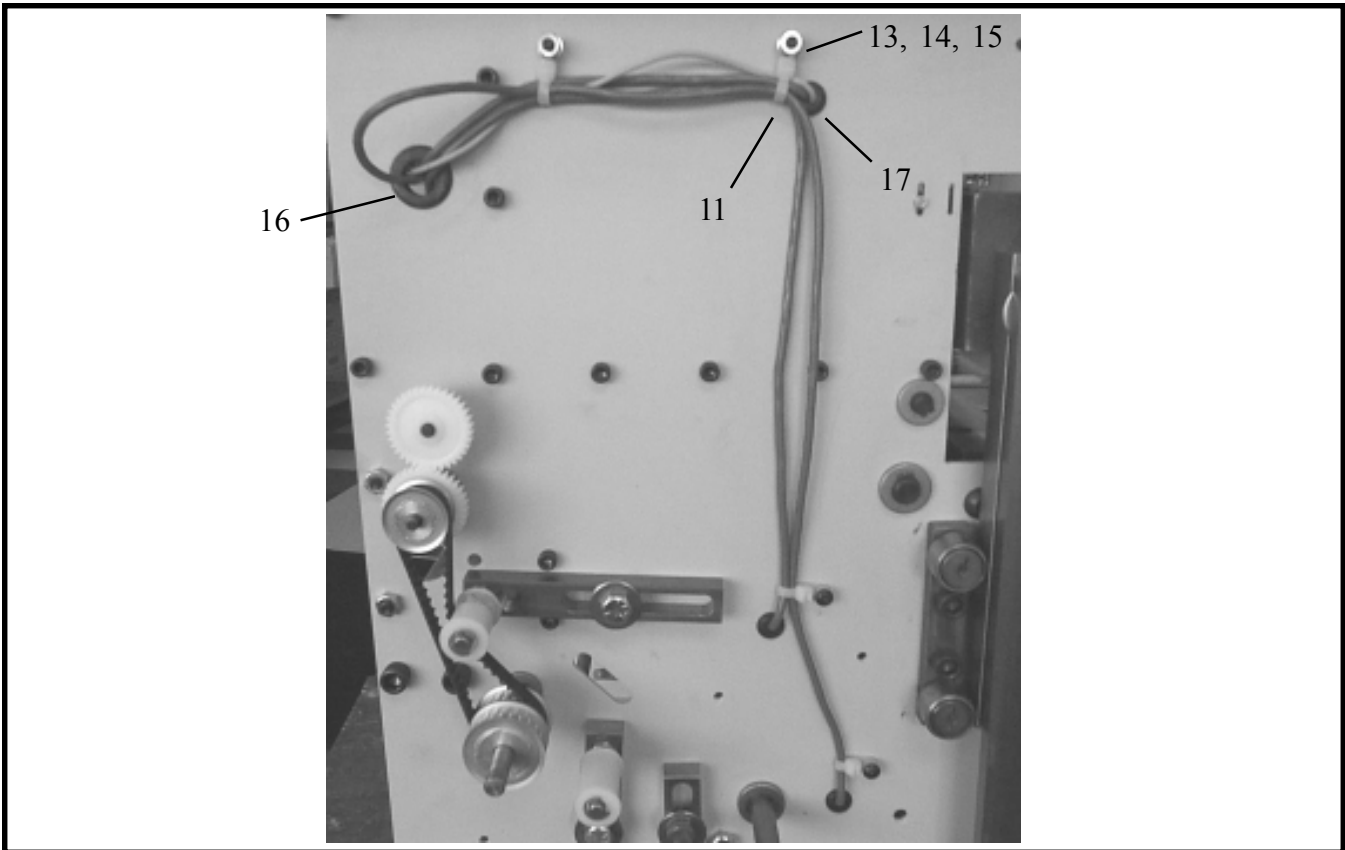
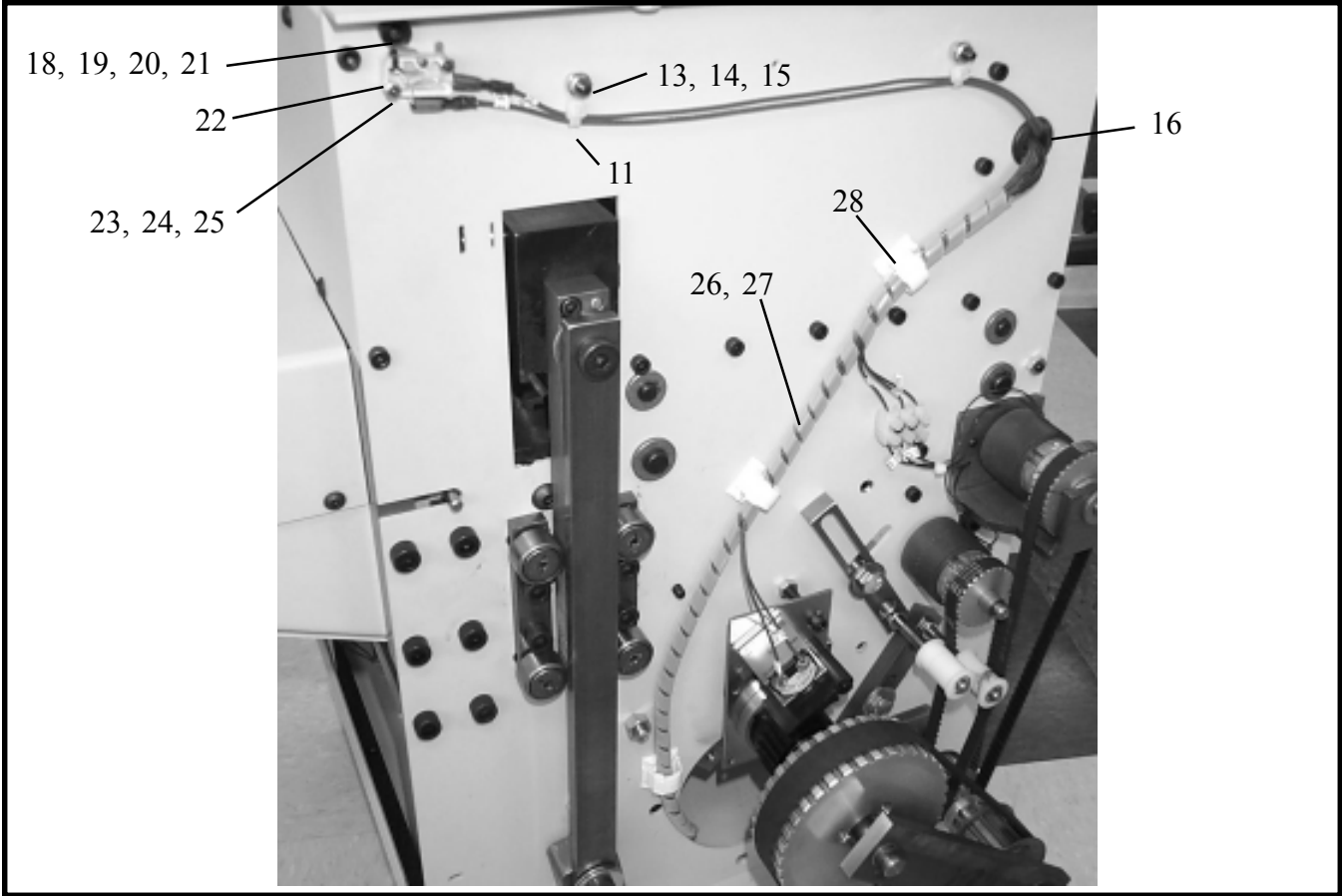

Trimmer

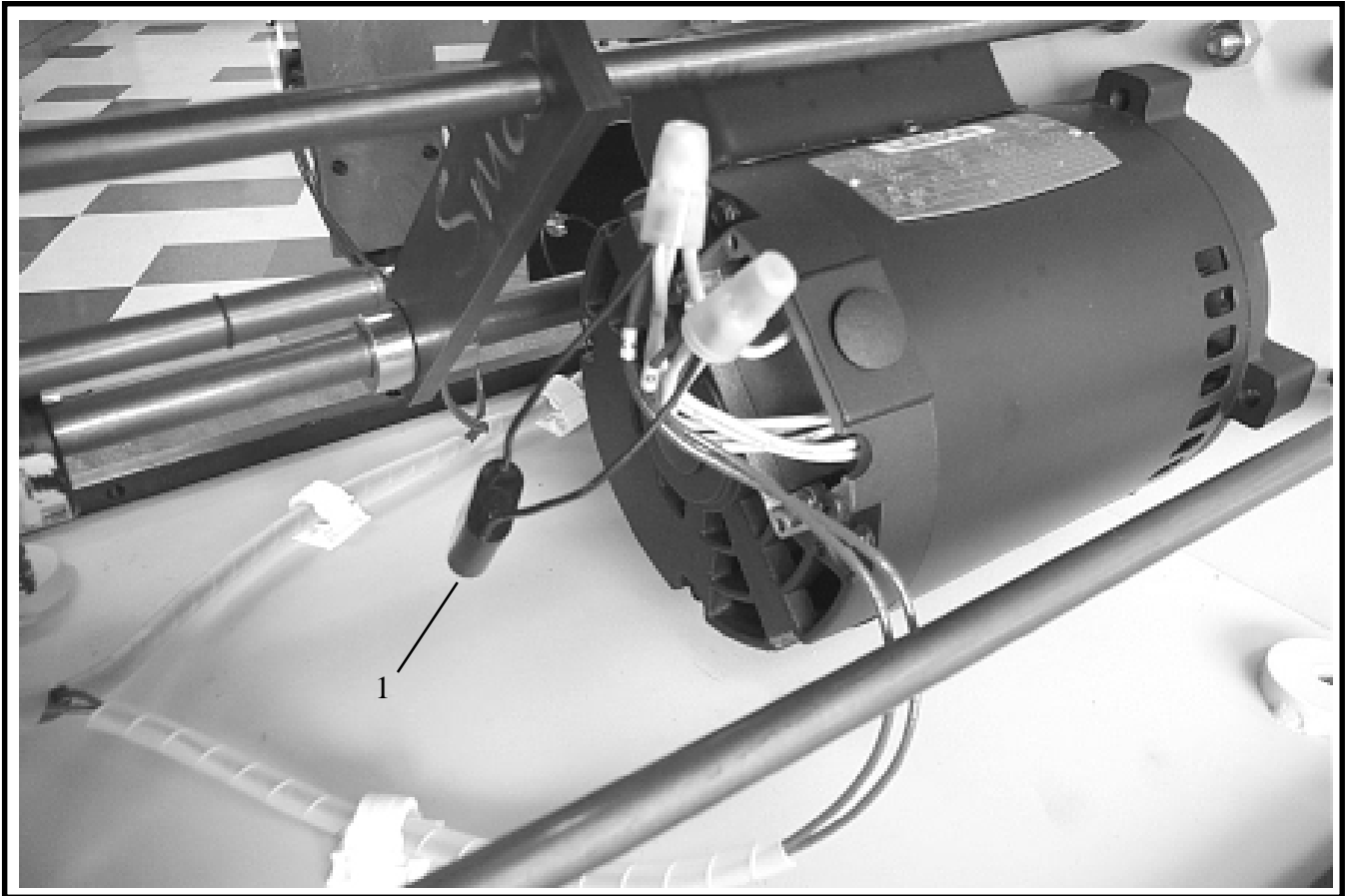
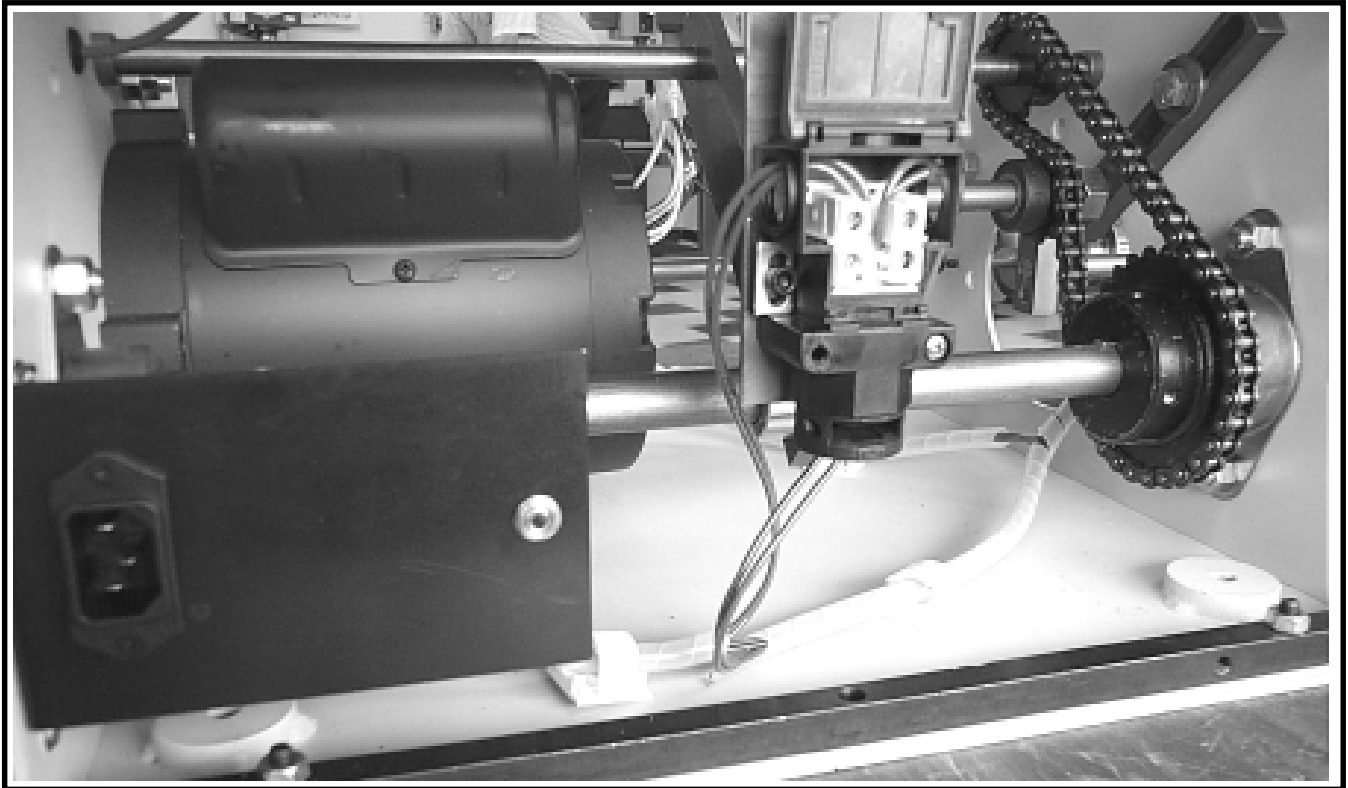

Index Number	Part Number	Part Name	Number Required
1	RTM1220F	Quencharc	1

MOTOR WIRING

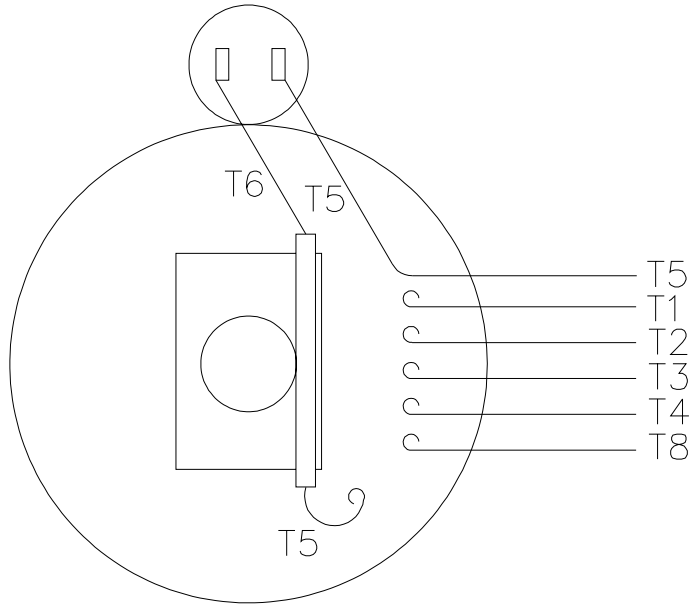

LINE LEADS			
			T1
	M		T2
			T3
	M		T4
			T8
	S		T5
		T5	T6
			T5
For C.W. rotation facing lead end			
	L1	L2	Join
115Vac	T1, T3, T5	T2, T4, T8	---
230Vac	T1	T4, T8	T2, T3, T5

(RTM1161F)

Trimmer

WIRING DIAGRAM

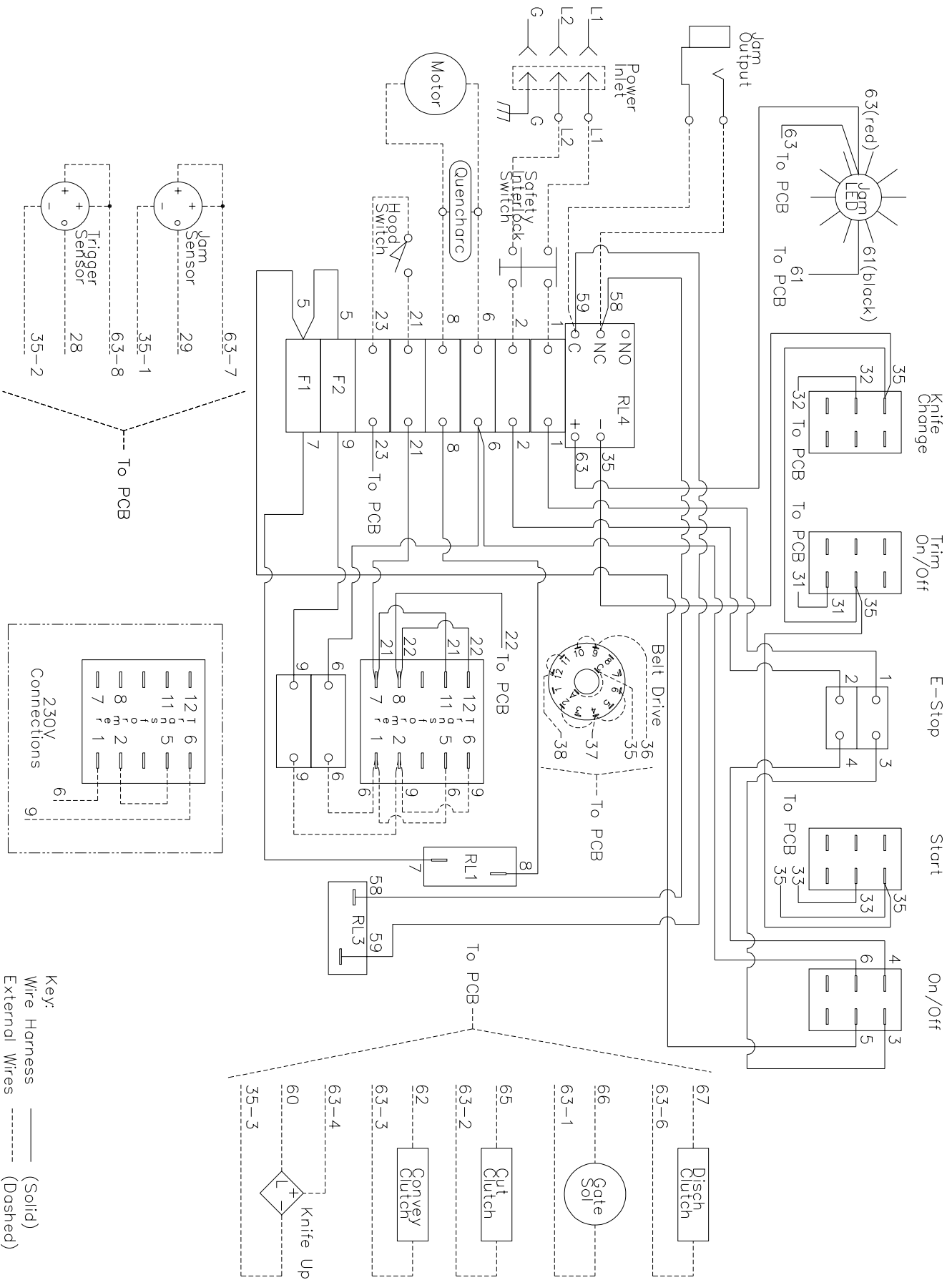

(SK891A)

ELECTRICAL SCHEMATIC

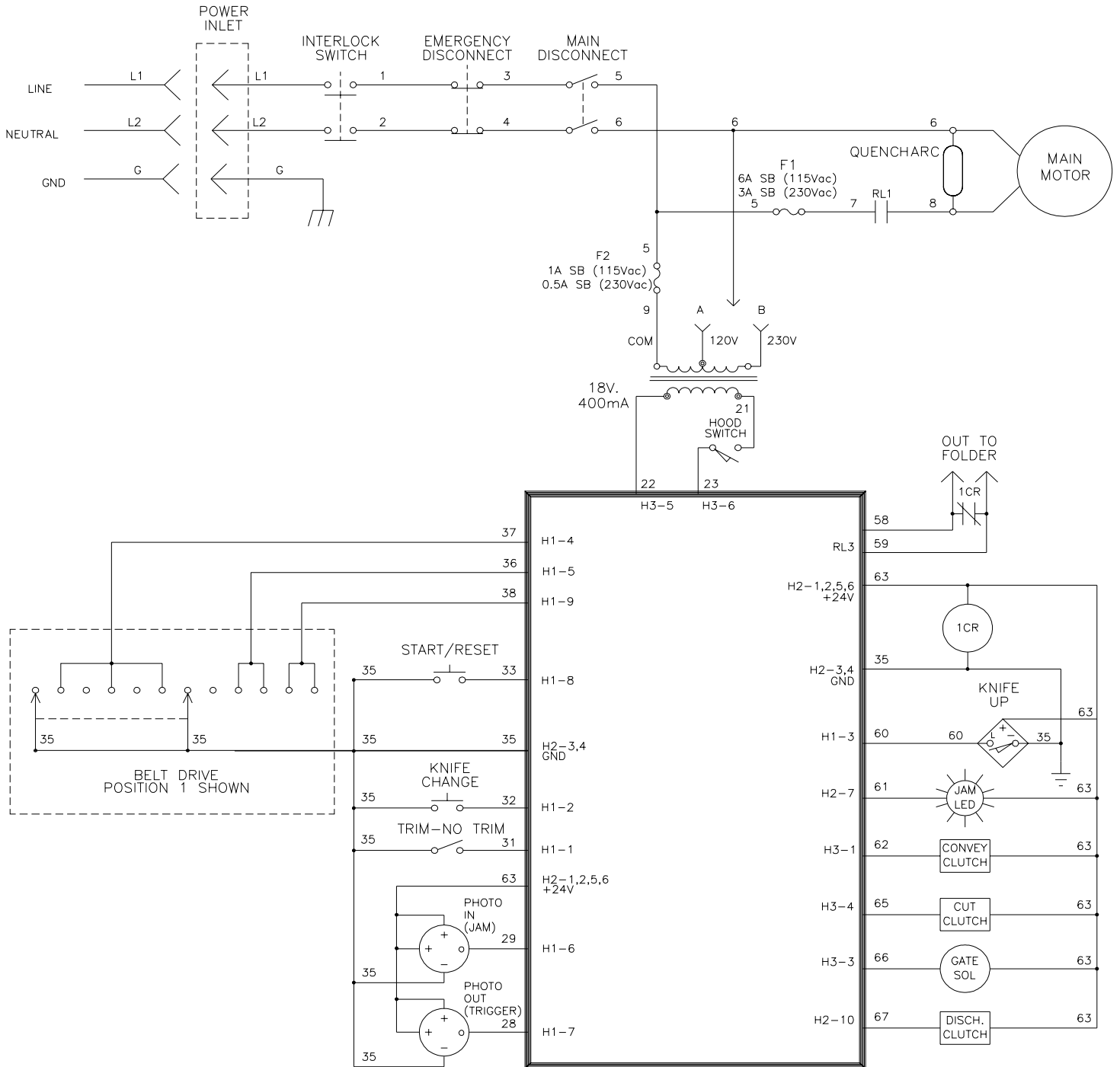

(SK891)



3134 Industry Drive
North Charleston, SC 29418
800-223-2508
www.mbmcorp.com
sales@mbmcorp.com

