

ProSource Packaging, Inc.
14911 Stuebner Airline Suite A
Houston, TX 77069
800-203-0233
www.Machine-Solution.com

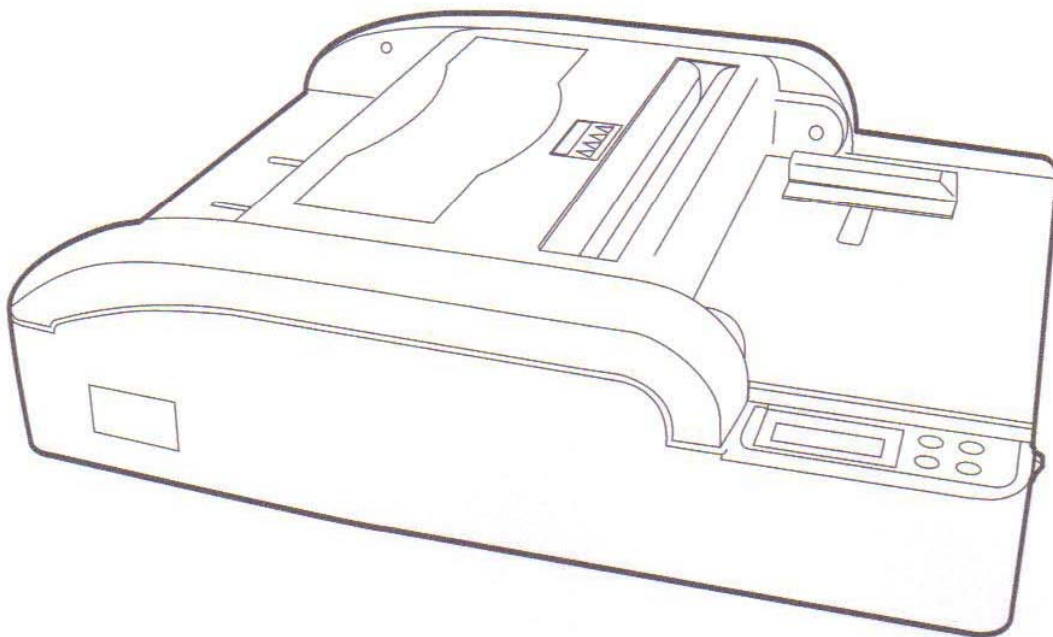

Part Catalogue



1. BASE SECTION

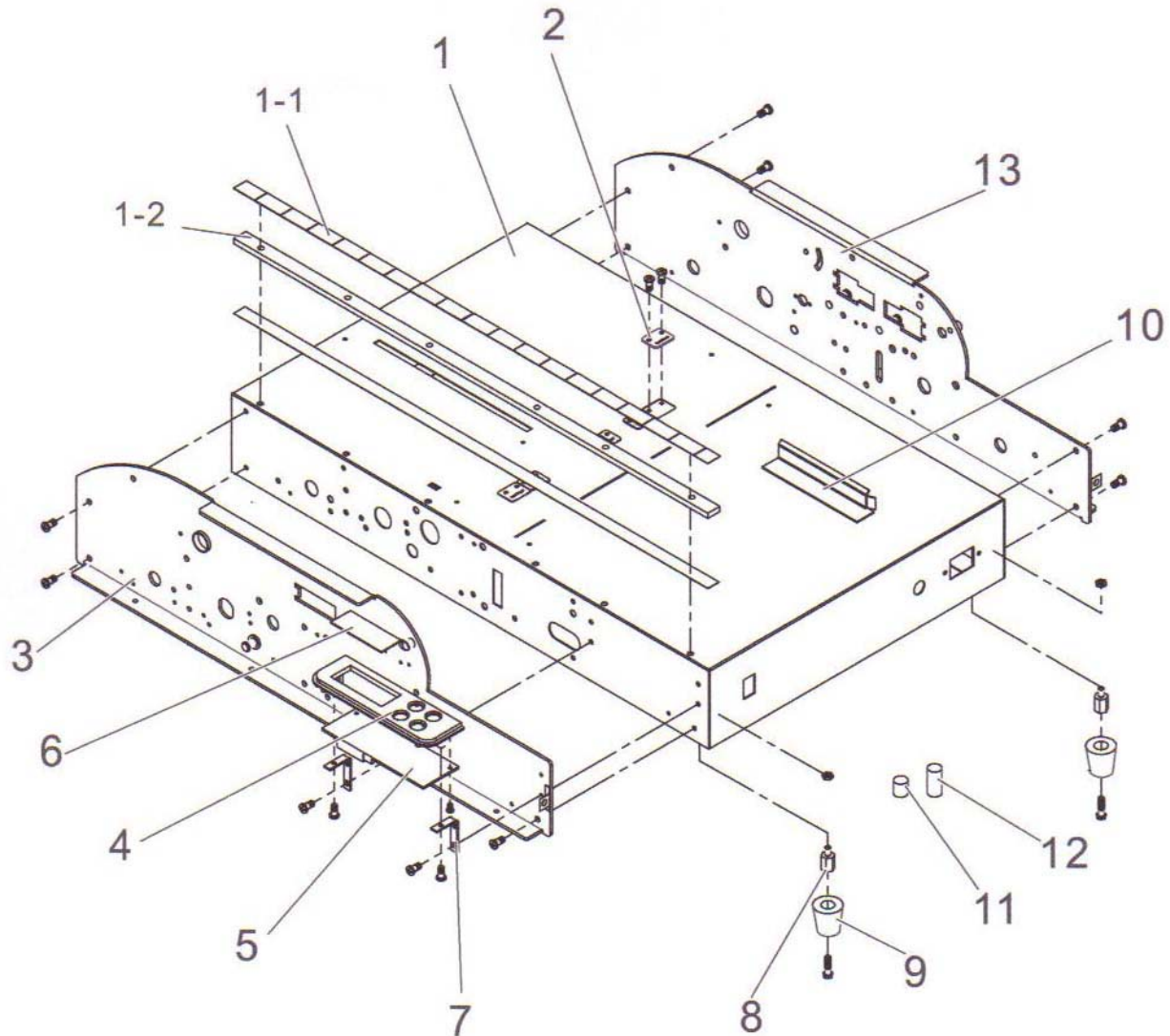

No	PART NO	DESCRIPTION	QTY
1		BASE ASSEMBLY	1
1-1	ASSEMBLY UNIT	SCALE	1
1-2		PLATE	1
2		ANVIL	5
3		FRAME F	1
4		CONTROL PANEL	1
5		PANEL P.W.B. UNIT	1
6		ACRYLIC PLATE	1
7		PANEL BRACKET	2
8		SCREW	4
9		RUBBER FOOT	4
10		PAPER SIDE GUIDE	1
11		OPTION STOPPER	1
12		OPTION STOPPER	1
13		FRAME B	1

2. PAPER JOGGER SECTION

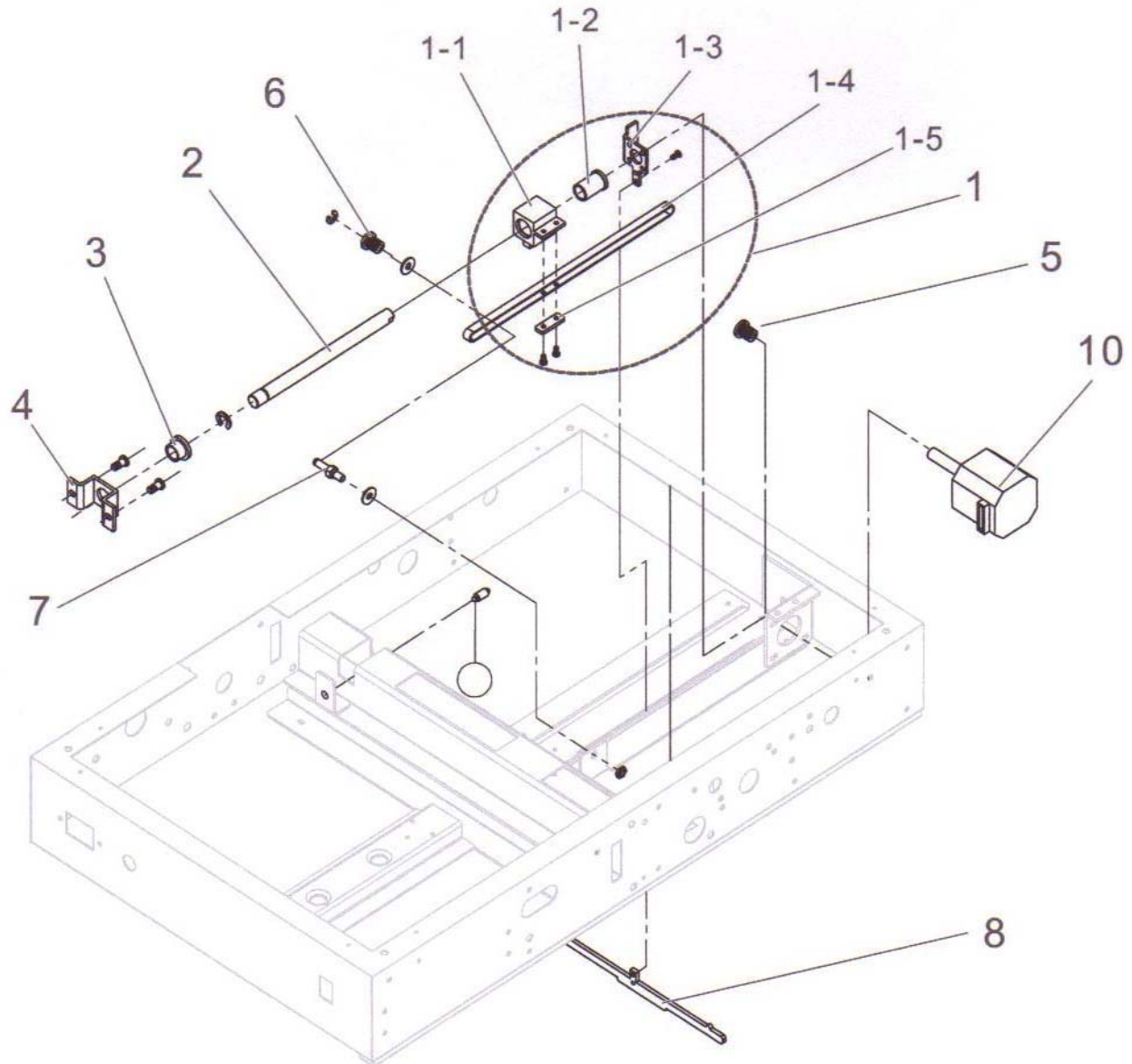

No	PART NO	DESCRIPTION	QTY
1	ASSEMBLY UNIT	GUIDE BLOCK ASSEMBLY	1
1-1		GUIDE BLOCK	1
1-2		COLLAR	1
1-3		ANGLE	1
1-4		TIMING BELT	1
1-5		PLATE	1
2		SHAFT	1
3		COLLAR	1
4		ANGLE	1
5		GEAR	1
6		GEAR	1
7		STUD	1
8		SIDE GUIDE	1
9		BALL RETAINER	2
10		STEP MOTOR	1

3. FOLDING BLADE SECTION

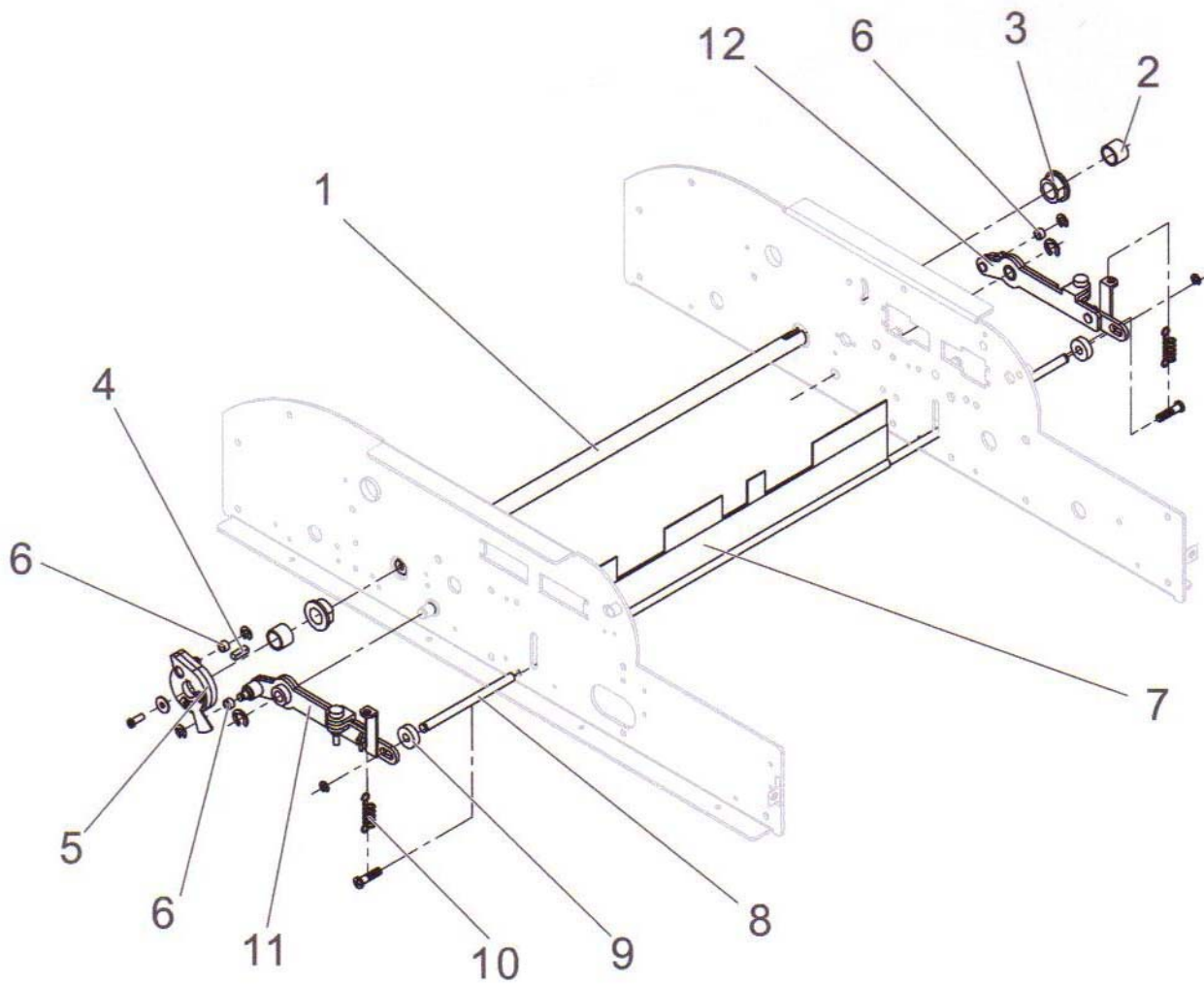

<u>No</u>	<u>PART NO</u>	<u>DESCRIPTION</u>	<u>QTY</u>
1		SHAFT	1
2		HOLDER	2
3		COLLAR	2
4		KEY	1
5		CAM F	1
6		BEARING	3
7		FOLDING BLADE	1
8		SHAFT	1
9		COLLAR	2
10		SPRING T	2
11		LEVER F	1
12		LEVER B	1

4. STAPLING SECTION

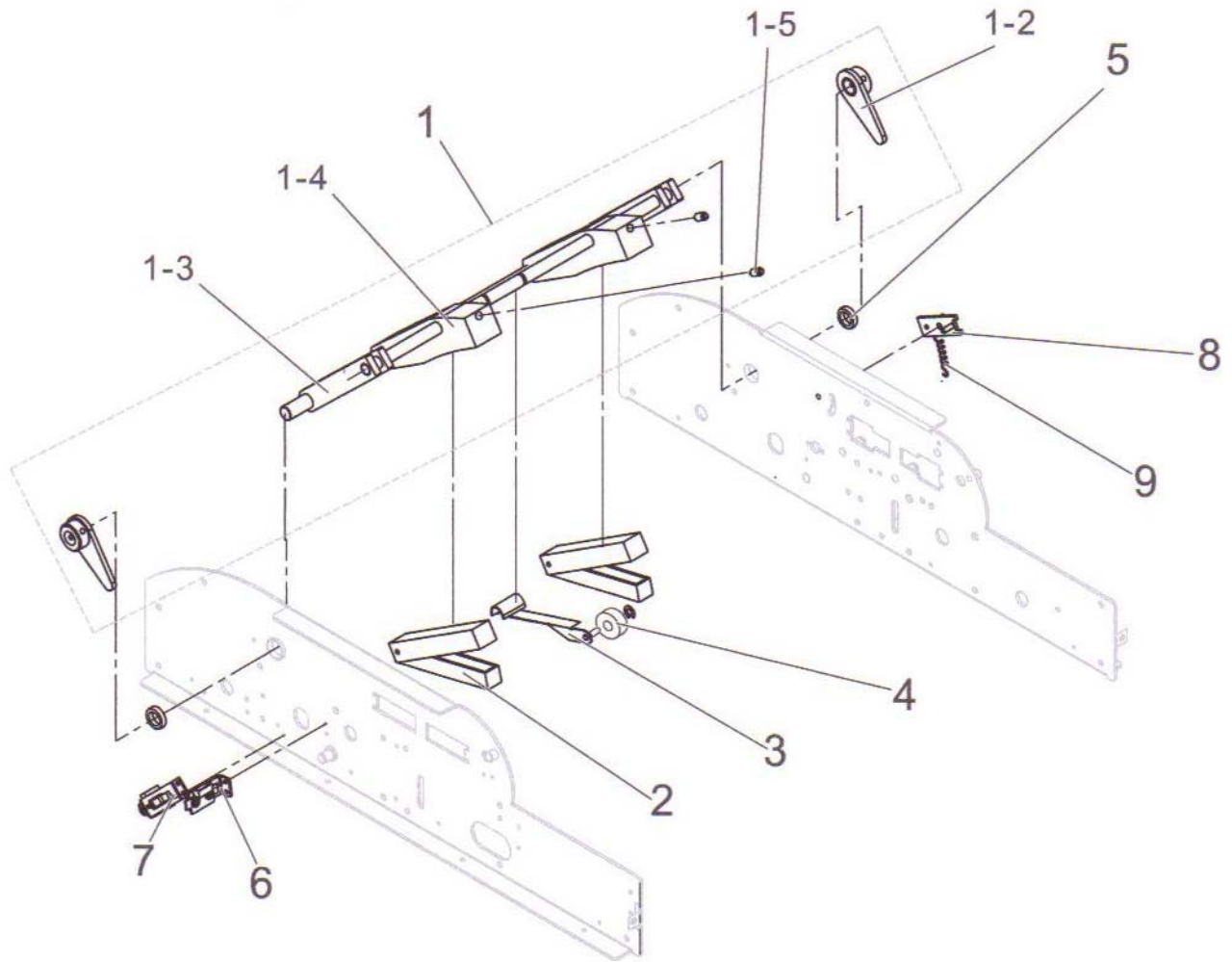

No	PART NO	DESCRIPTION	QTY
1		STAPLE ASSEMBLY	1
1-1	ASSEMBLY UNIT	LEVER F	1
1-2		LEVER B	1
1-3			4
1-4		STAPLER HEAD COVER	2
1-5		BALL RETAINER	2
2		STAPLER HEAD	2
3		PRESS ROLLER HOLDER	1
4	BMT1	BEARING	1
5		COLLAR	2
6		SENSOR HOLDER R	1
7		SENSOR HOLDER L	1
8		BLOCK	1
9		SPRING T	1

5. DRIVING SECTION

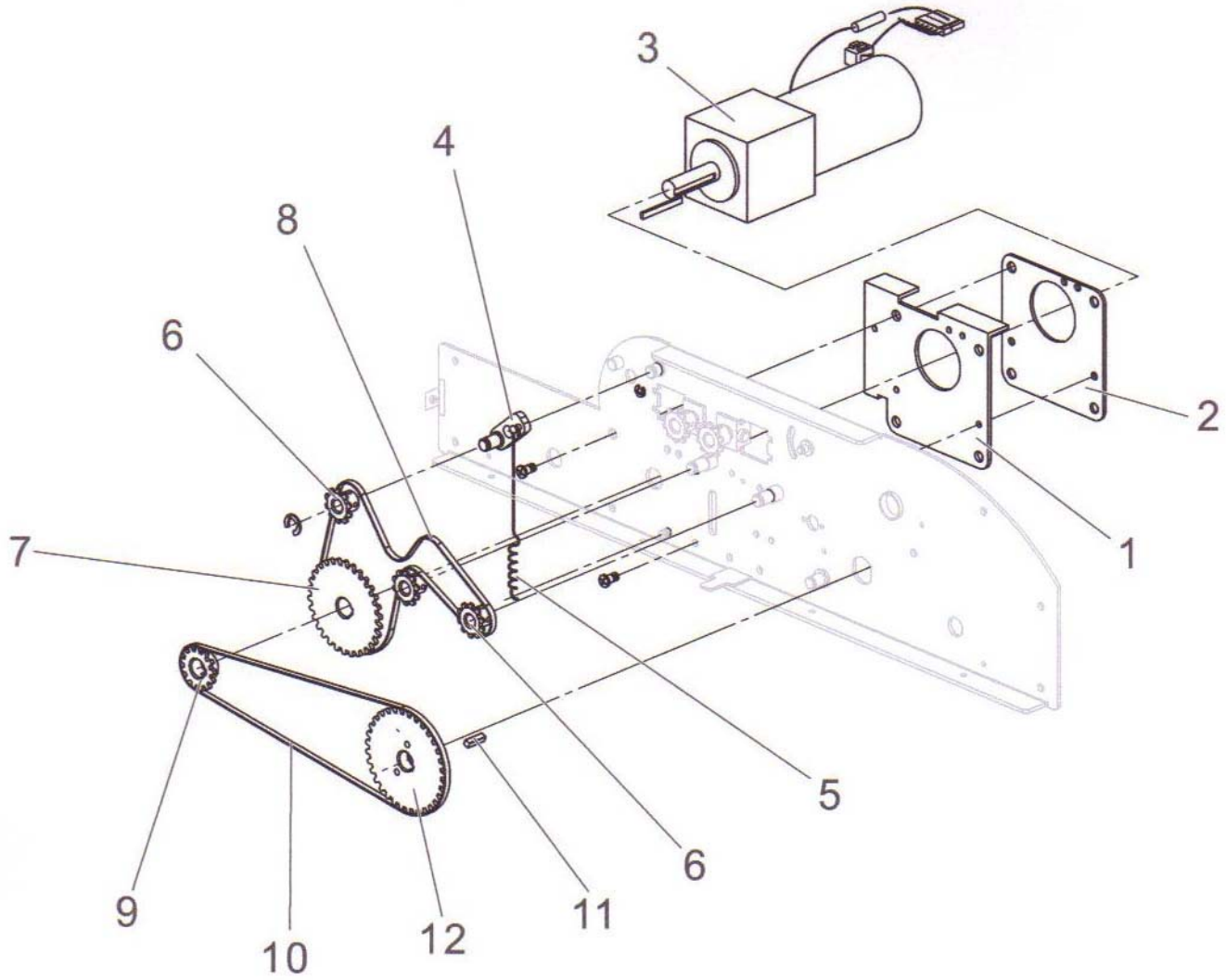

<u>No</u>	<u>PART NO</u>	<u>DESCRIPTION</u>	<u>QTY</u>
1		PLATE ASSEMBLY	1
2		PLATE	1
3		MOTOR (110V)	1
4		BLOCK	1
5		SPRING T	1
6		SPROCKET IV	3
7		MOTOR SPROCKET	1
8		CHAIN	1
9		SPROCKET	1
10		CHAIN	1
11		KEY	1
12		SPROCKET ASSEMBLY	1
			1
			1

6. FOLDING SECTION

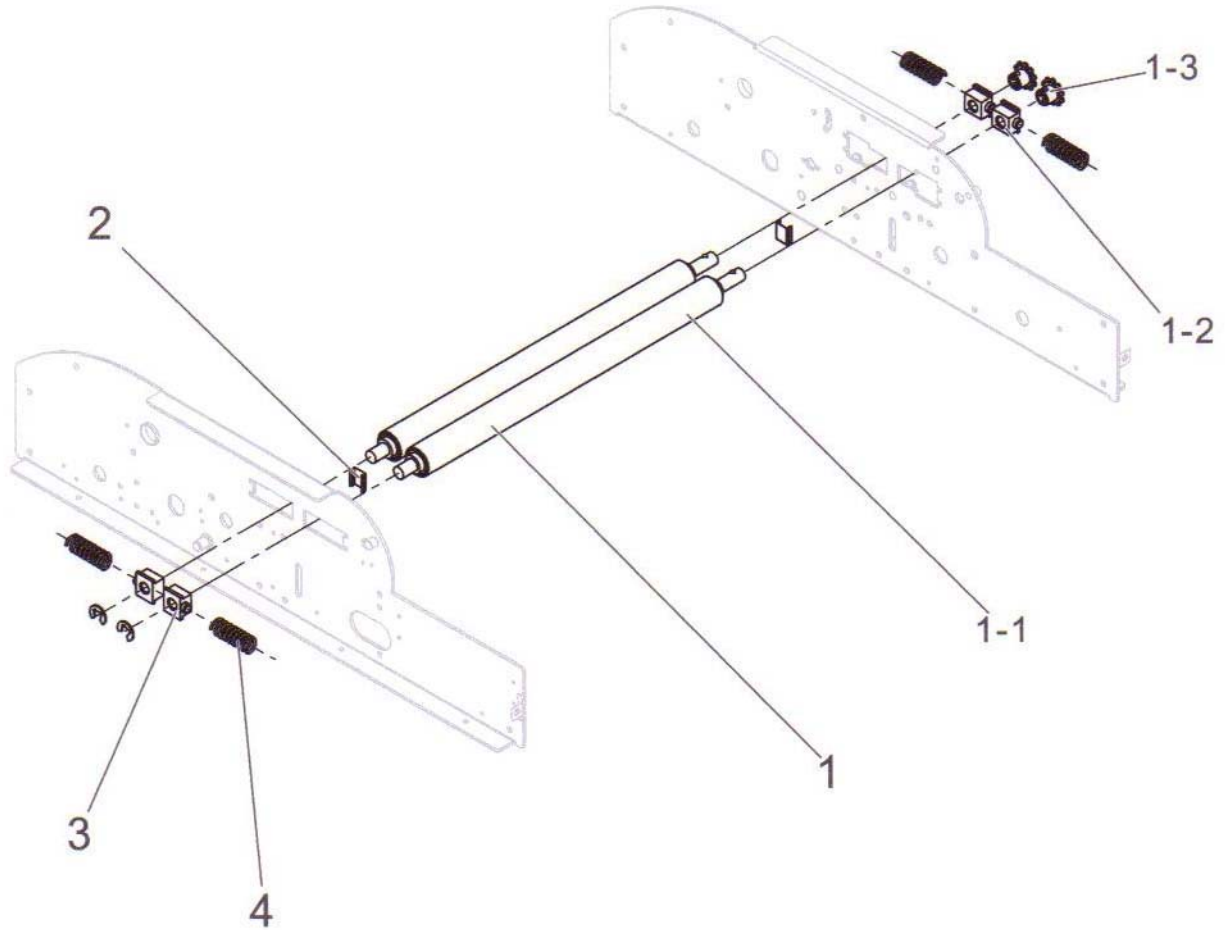

<u>No</u>	<u>PART NO</u>	<u>DESCRIPTION</u>	<u>QTY</u>
1		ROLLER ASSEMBLY	2
1-1		ROLLER	1
1-2		SQUARE METAL	1
1-3		SPROCKET IV	1
2			2
3		SQUARE METAL	2
4		SPRING C	4

7. EXTERIOR SECTION

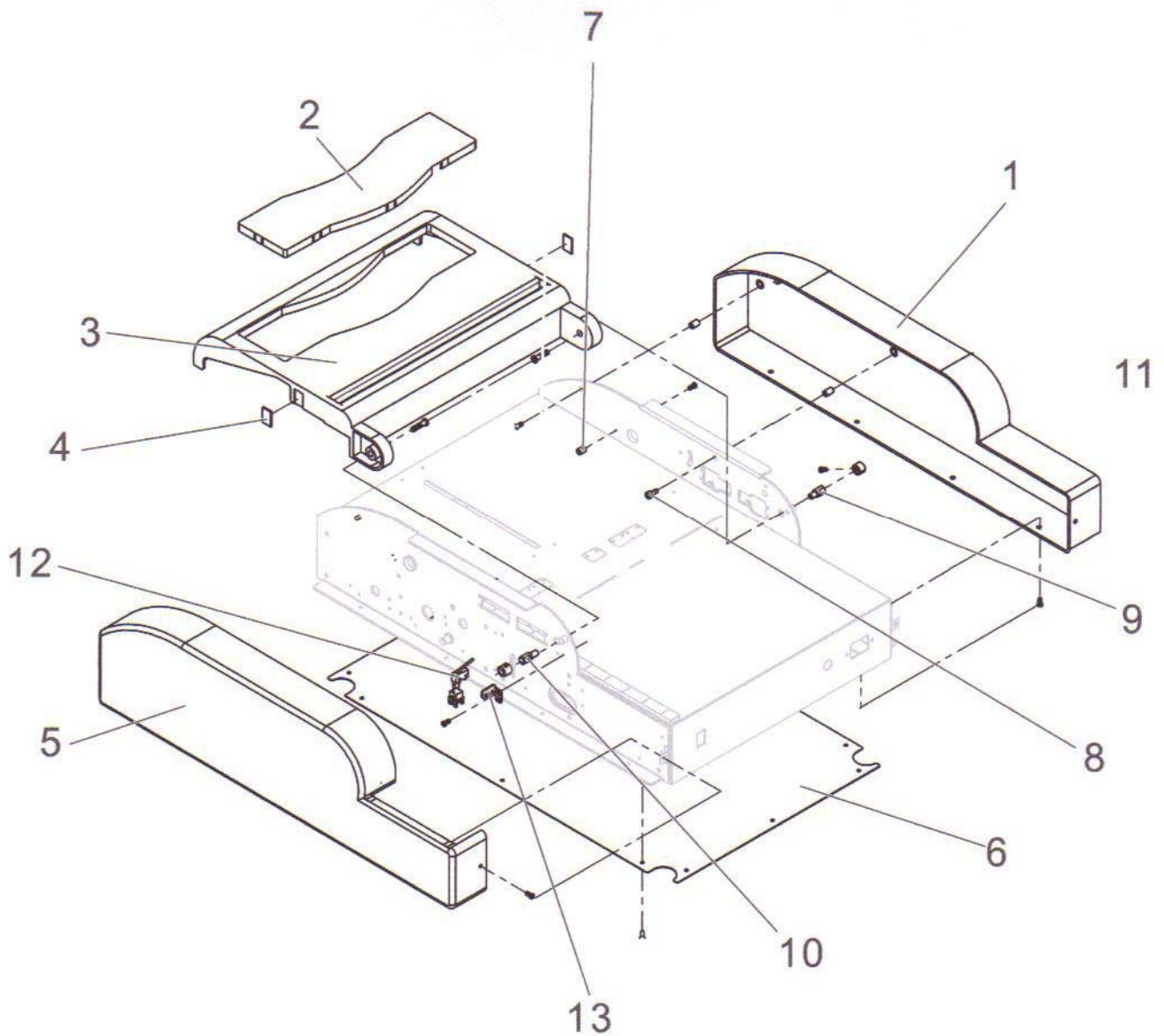

<u>No</u>	<u>PART NO</u>	<u>DESCRIPTION</u>	<u>QTY</u>
1		COVER B	1
2		ACRYLIC COVER	1
3		TOP COVER	1
4		MAGNETIC	2
5		COVER F	1
6		BASE PLATE	1
7		COVER STOPPER	2
8		COVER SCREW	2
9		PILLAR	1
10		PILLAR	1
11		COLLAR	2
12		TOP COVER SWITCH ASSEMBLY	1
13		BRACKET	1

8. ELECTRICAL SECTION 1

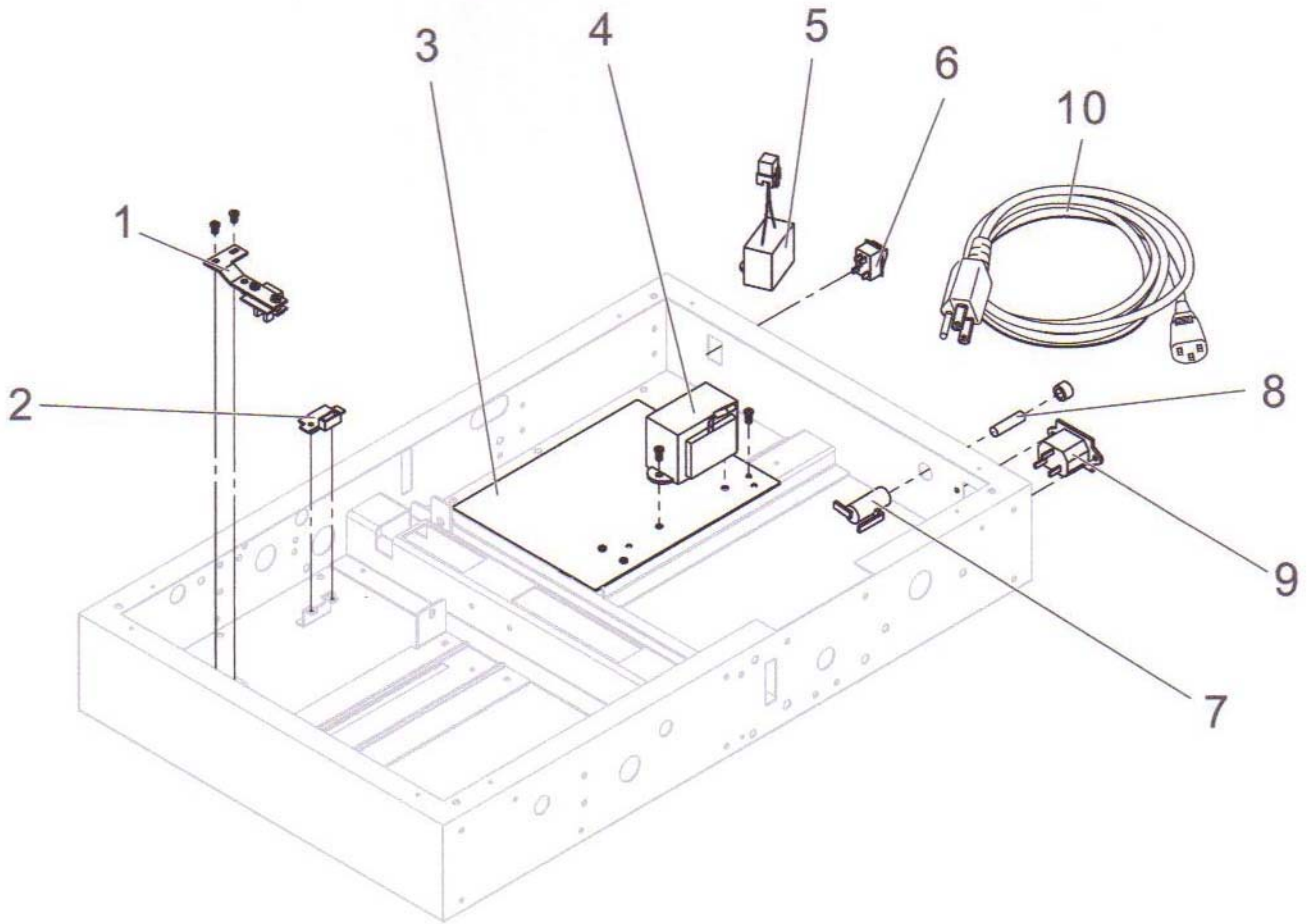

<u>No</u>	<u>PART NO</u>	<u>DESCRIPTION</u>	<u>QTY</u>
1		SENSOR BRACKET	1
2		SENSOR ASSEMBLY	1
3		MAIN BOARD BRACKET	1
4		TRANSFORMER (110V)	1
5		MOTOR CAPACITOR (110V)	1
6		MAIN POWER SWITCH	1
7		FUSE HOLDER	1
8		FUSE	1
9		INLET	1
10		POWER CORD (USA)	1

9. ELECTRICAL SECTION 2

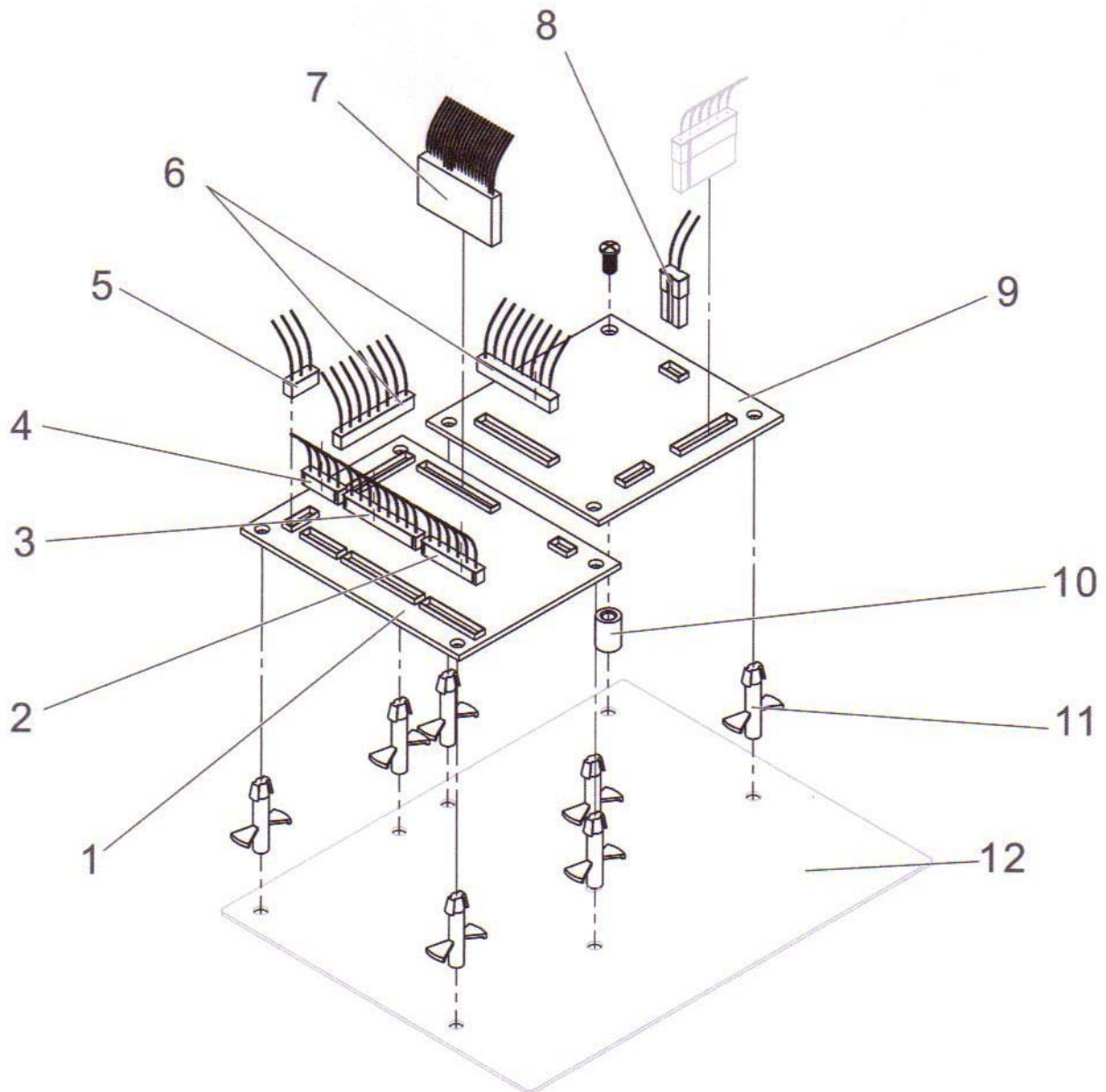

<u>No</u>	<u>PART NO</u>	<u>DESCRIPTION</u>	<u>QTY</u>
1		MAIN P.W.B.	1
2		BUNDLE WIRE	1
3		BUNDLE WIRE 8P	1
4		BUNDLE WIRE 4P	1
5		BUNDLE WIRE 3P	1
6		BUNDLE WIRE 8P	1
7		BUNDLE WIRE 20P	1
8		BUNDLE WIRE 2P	1
9		POWER SUPPLY UNIT (110V)	1
10		COLLAR	1
11		BOARD SPACER	1
12		MAIN BOARD BRACKET	1

10. ELECTRICAL SECTION 2

