

Spinnit® FM-2 Manual Paper Drill

USER'S MANUAL



ProSource Packaging, Inc.  
14911 Stuebner Airline Suite A  
Houston, TX 77069  
800-203-0233  
www.Machine-Solution.com

**Before operating this equipment, please read these instructions completely and keep these operating instructions for future reference.**

Serial Number: \_\_\_\_\_  
Date of Purchase: \_\_\_\_\_  
Dealer: \_\_\_\_\_  
Address: \_\_\_\_\_  
\_\_\_\_\_  
Telephone Number: \_\_\_\_\_

# Table Of Contents

## 1 - Introduction

- 1.1 Your New FM-2 Paper Drill..... Page 01
- 1.2 Shipping Damage Inspection..... Page 01

## 2 - Safety

- 2.1 Safety Instructions..... Page 02
- 2.2 Warning Labels..... Page 03
- 2.3 Grounding Instructions..... Page 04

## 3 - Setting Up Your Machine

- 3.1 Loose Items Inventory..... Page 05
- 3.2 Accessories Warning..... Page 05
- 3.3 Uncrating and Removing From the Pallet..... Page 06
- 3.4 Installing the Leveling Feet..... Page 06
- 3.5 Attaching the Paper Side Stops..... Page 07
- 3.6 Attaching the Chip Bag..... Page 07
- 3.7 Choosing and Installing the Pattern Bar..... Page 08
- 3.8 Electrical Instructions..... Page 08

## 4 - Operation

- 4.1 Protective Guard..... Page 09
- 4.2 Drill Bit Removal and Installation..... Page 09
- 4.3 Adjusting the Table Height..... Page 10
- 4.4 Adjusting the Back-Gauge Assembly... Page 10
- 4.5 Traversing the Table..... Page 11
- 4.6 Drilling Procedures..... Page 12
- 4.7 Tips on Drilling..... Page 12

## 5 - Maintenance

- 5.1 Safety..... Page 13
- 5.2 Annual Lubrication..... Page 13

## 6 - Trouble Shooting Guide

- 6.1 Determining the Cause and Correction to Certain Problems..... Page 14

# 1 - Introduction

## 1.1 - Your New FM-2 Paper Drill

- Thank you for your purchase of the Spinnit®FM-2 Paper Drill.
- We ask that you take a moment to fill in the serial number and other information on the front cover of the manual. Please keep this manual as a reference for future use.
- For parts and service, please contact the Lassco-Wizer Dealer from whom you purchased the machine. If you require assistance in locating a Lassco-Wizer Dealer please contact our customer service department at 585-436-1934. Please have the model of your machine and the serial number when you call.
- If you wish to write to us, send correspondence to:

Lassco-Wizer  
Attn: Customer Service  
485 Hague Street  
Rochester, NY 14606

## 1.2 - Shipping Damage Inspection

- Remove the machine from the carton and inspect for any shipping damage. If any damage is present, report the damage to the carrier immediately; failure to do so may void any warranties.

## 2 - Safety

### 2.1 - Safety Instructions

- All operators must read and understand the Users Manual including all safety instructions before using this equipment. Failure to fully understand the safety instructions can result in personal injury. If after reading the manual you are still uncertain about use, please contact the dealer from whom you purchased the machine for assistance. If you need contact information for a Service Technician nearest you please call 585-436-1934.
- SAFETY OF THIS EQUIPMENT IS THE RESPONSIBILITY OF THE USER(S).
- Please read and follow all warning labels on your machine.
- INDUSTRIAL AND IN-PLANT USE ONLY. This equipment is for use in industrial and in-plant areas only and must be operated by trained and qualified personnel.
- WEAR PROPER APPAREL. Do not wear loose clothing, gloves, neckties, rings, bracelets, or other jewelry which may get caught in moving parts. Non slip footwear is recommended. Wear protective hair covering to contain long hair.
- Keep hands clear while operating machine.
- ALWAYS USE SAFETY GLASSES. Also use face or dust mask if drilling operation is dusty. Everyday eyeglasses only have impact resistant lenses, they are NOT safety glasses.
- KEEP GUARDS IN PLACE and in working order.
- Always disconnect the power before servicing this machine. Service should only be performed by a QUALIFIED TECHNICIAN.
- Always turn the machine to off mode and wait for the drills to stop spinning before installing or removing drill bits. Keep hands away from drills when operating. PLEASE NOTE THAT THE DRILL BITS MAY BE HOT AFTER USE. PROCEED WITH CAUTION WHEN CHANGING THE DRILL BITS.
- DON'T USE IN DANGEROUS ENVIRONMENT. Don't use this machine in damp or wet locations, or expose it to rain. Keep work area well lighted.
- THIS MACHINE IS DESIGNED FOR ONE PERSON OPERATION. Never operate the machine with more than one person.
- KEEP CHILDREN AWAY. All visitors should be kept a safe distance from the work area.
- MAKE WORKSHOP KID-PROOF with padlocks or master switches.
- DON'T FORCE MACHINE. It will do the job better and safer at the rate for which it was designed.
- USE RIGHT MACHINE. Don't force tool or attachment to do a job for which it was not designed.
- MAINTAIN MACHINE WITH CARE. Keep tools sharp and clean for best and safest performance. Follow instructions for lubricating and changing accessories.
- REMOVE ADJUSTING KEYS AND WRENCHES. Form habit of checking to see that keys and adjusting wrenches are removed from machine before turning it on.
- KEEP WORK AREA CLEAN. Cluttered areas and benches invite accidents.
- DISCONNECT MACHINE before servicing; when changing accessories, such as drill bits, drill blocks, and the like.
- REDUCE THE RISK OF UNINTENTIONAL STARTING. Make sure the power switch is in the off position before plugging in.
- USE RECOMMENDED ACCESSORIES. Consult the user's manual for recommended accessories. The use of improper accessories may cause risk of injury to persons.
- NEVER STAND ON MACHINE. Serious injury could occur if the machine is tipped.
- DON'T OVERREACH. Keep proper footing and balance at all times.
- CHECK DAMAGED PARTS. Before further use of the machine, a guard or other part that is damaged should be carefully checked to determine that it will operate properly and perform its intended function--check for alignment of moving parts, binding of moving parts, breakage of parts, mounting, and any other conditions that may affect its operation. A guard or other part that is damaged should be properly repair or replaced.
- NEVER LEAVE MACHINE RUNNING UNATTENDED. TURN POWER OFF. Don't leave machine until it comes to a complete stop.

## 2 - Safety

### 2.2 - Warning Labels

#### English



- WARNING: DO NOT EXPOSE TO RAIN OR USE IN DAMP LOCATIONS.



#### ⚠ WARNING

Read and understand operator's manual and all other safety instructions before using this equipment

#### ⚠ WARNING

FOR INDUSTRIAL AND IN-PLANT USE ONLY.

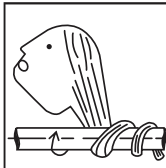

#### ⚠ WARNING

Entanglement hazard.  
Rotating parts.  
Do NOT operate with exposed long hair, jewelry or loose clothing.



#### ⚠ WARNING

**Moving parts can crush and cut**  
**Keep hands clear while operating machine.**



#### ⚠ WARNING

Risk of eye injury.  
Wear eye protection.

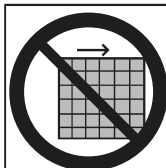

#### ⚠ WARNING

Risk of Injury.  
Do NOT operate without guards in place.



#### ⚠ WARNING

Drill bits may be hot after use.  
Allow drill bits to cool down before touching



#### ⚠ DANGER

**Severe shock hazard.**

Only authorized personnel may service this equipment.  
Turn power OFF before entry.



#### French

- AVERTISSEMENT: NE PAS EXPOSER À LA PLUIE ET NE PAS UTILISER DANS LES EMPLACEMENTS HUMIDES

#### ⚠ AVERTISSEMENT

Lire et bien comprende le manuel de l'opérateur avant d'utiliser cette machine.  
Le fait de ne pas suivre les consignes d'utilisation peut entraîner des blessures graves ou endommager l'équipement.

#### ⚠ AVERTISSEMENT

POUR UTILISATION INDUSTRIELLE ET EN USINE SEULEMENT.

#### ⚠ AVERTISSEMENT

Risque d'enchevêtrement.  
Pièces rotatives.  
Ne portez jamais de vêtements amples ou de bijoux et attachez-vous les cheveux lorsque vous opérez cette machine.

#### ⚠ AVERTISSEMENT

Les pièces mobiles peuvent écraser et couper.  
Éloignez les mains lorsque vous opérez cette machine.

#### ⚠ AVERTISSEMENT

Risque de blessures aux yeux.  
Protection des yeux nécessaire.

#### ⚠ AVERTISSEMENT

Faire attention de ne pas se blesser.  
Ne pas utiliser cette machine sans la présence de tous les dispositifs de sécurité.

#### ⚠ AVERTISSEMENT

Les outils de forage peuvent chauffer à l'usage.  
Laisser refroidir les outils de forage avant de les toucher.

#### ⚠ DANGER

Grave risqué d'électrocution.  
Seul le personnel autorisé peut faire l'entretien de cet équipement.  
COUPEZ l'alimentation électrique avant d'entrer.

## 2.3 - Grounding Instructions

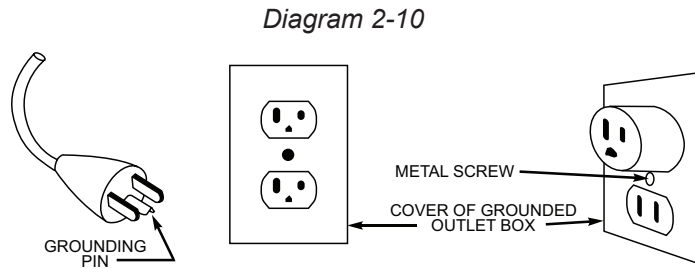

- In the event of a malfunction or breakdown, grounding provides a path of least resistance for electric current to reduce the risk of electric shock. This tool is equipped with an electric cord having an equipment-grounding conductor and a grounding plug. The plug must be plugged into a matching outlet that is properly installed and grounded in accordance with all local codes and ordinances.
- **DO NOT MODIFY THE PLUG PROVIDED.** If it will not fit the outlet, have the proper outlet installed by a **QUALIFIED ELECTRICIAN**.
- Improper connection of the equipment-grounding conductor can result in a risk of electric shock. The conductor with insulation having an outer surface that is green with or without yellow stripes is the equipment-grounding conductor. If repair or replacement of the electric cord or plug is necessary, do not connect the equipment-grounding conductor to a live terminal. Check with a **QUALIFIED ELECTRICIAN** or service personnel if the grounding instructions are not completely understood, or if in doubt as to whether the tool is properly grounded. Use only 3-wire extension cords that have 3-prong grounding plugs and 3-pole receptacles that accept the machine's plug.
- This machine is intended for use on a circuit that has an outlet that looks like the one illustrated in diagram 2-10. The machine has a grounding plug that looks like the plug illustrated in diagram 2-10. Make sure the machine is connected to an outlet having the same configuration as the plug. No adapter is available or should be used with this machine. If the machine must be reconnected for use on a different type of electric circuit, the reconnection should be made by qualified service personnel; and after reconnection, the tool should comply with all local codes and ordinances.

# 3 - Setting Up Your Machine

## 3.1 - Loose Items Inventory

- Please remove and inspect the following items:



EBM2-1048: Chip Bag (1)

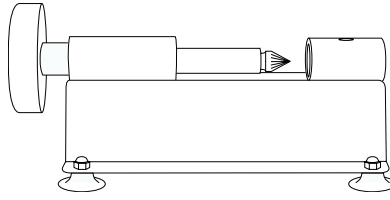

MS-1: Drill Sharpener (1)

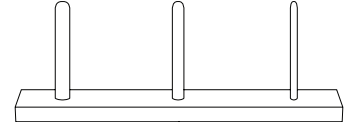

CC-2: Chip Clearer (1)

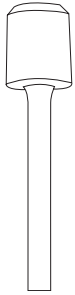

Hollow Drill Bit (1)  
(this item may be installed)



SPIN-EZE: Drill Bit  
Lubricant (1)

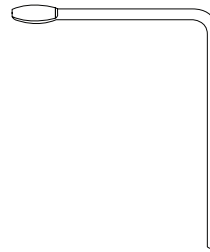

EBM-32: Chuck Re-  
lease Key (1)



EBM-41: Sharpening  
Stone (1)

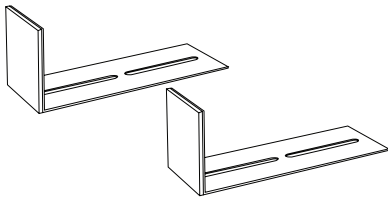

FM4-4006: Paper Side  
Stops (2)

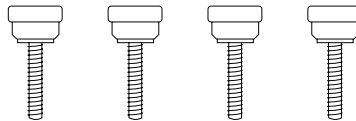

FM4-4007: Side Stop  
Screws (4)



EBM2-1034: 16" Drill Strip (1)  
(this item comes installed)

## 3.2 - Accessories Warning

- **USE RECOMMENDED ACCESSORIES.** Only use accessories approved by a Lassco-Wizer. The use of improper accessories may cause risk of injury to persons.

## 3 - Setting Up Your Machine

### 3.3 - Uncrating and Removing From the Pallet

- 3.3.1** Remove the wooden framing around the outside box.
- 3.3.2** Remove the box up and over the machine.
- 3.3.3** Remove the two (2) 5/16" bolts which are securing the machine to the pallet: access through the rear of the machine using a 5/16" wrench (not provided) as shown in diagram 3-10. Discard the two (2) 5/16" bolts.
- 3.3.4** Remove the FM-2 from the pallet carefully "stepping" it off the edge. DO NOT drop the machine. DO NOT lift by the table. Two people may be needed to remove the machine from the pallet safely.

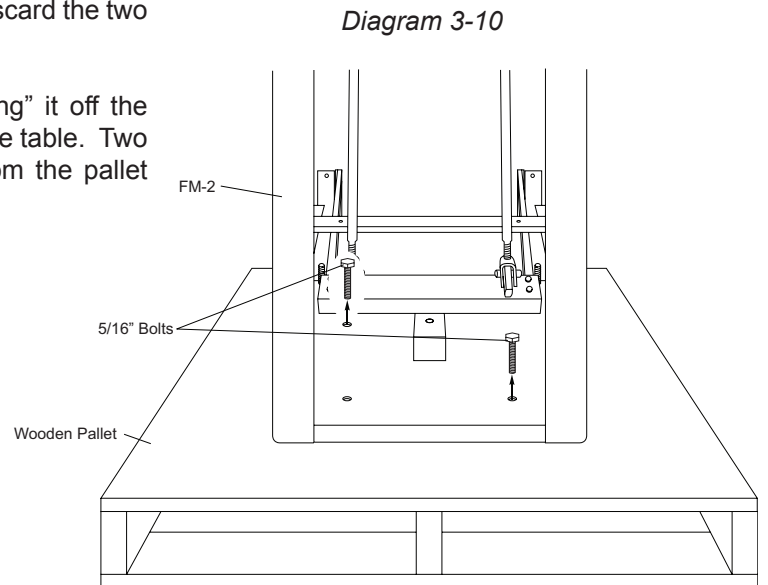

### 3.4 - Installing the Leveling Feet

- 3.4.1** Set the machine down in its desired location and determine if the machine is level, making sure that it does NOT rock in any direction. If it does, determine which Leveling Feet need to be adjusted and whether they need to be adjusted up or down.
- 3.4.2** If adjustment is needed, start by loosening the four (4) nuts which are accessed through the rear of the machine.
- 3.4.3** Next adjust the four (4) Leveling Feet by screwing them clockwise to raise the or counter-clockwise to lower. After each adjustment set the machine down completely to verify that the machine no longer rocks. Continue adjustment as needed until the machine sits securely in place. Tighten the four (4) nuts down to secure the position of the Leveling Feet.

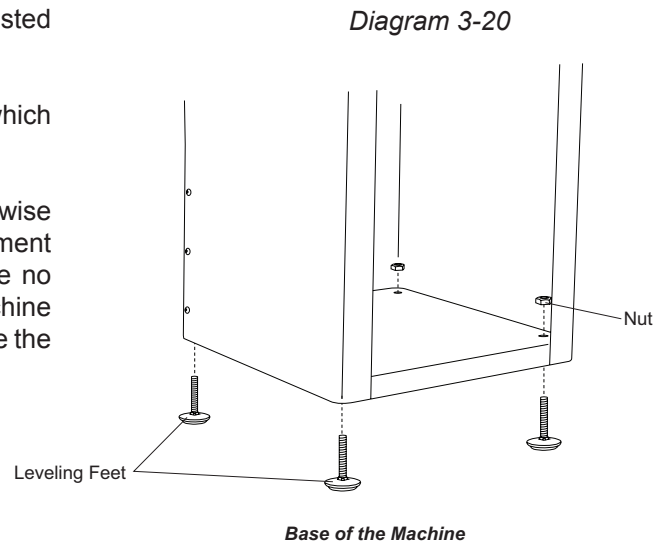

## 3 - Setting Up Your Machine

### 3.5 - Attaching the Paper Side Stops

- 3.5.1** Attach the Paper Side Stops (FM4-4006) using two (2) Side Stop Screws (FM4-4007) each. Position the Paper Side Stop as desired and tighten down with light pressure.

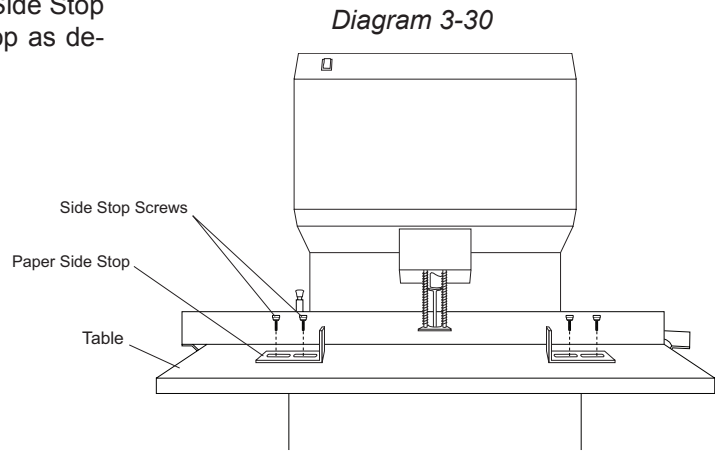

### 3.6 - Attaching the Chip Bag

- 3.6.1** Attach the Chip Bag (FMM6-650A) to the machine by stretching the mouth of the bag over the Master Chip Chute and hooking the aluminum bar onto the bracket located on the top flat portion of the master chip chute as shown. Please note that you must empty this bag as needed to avoid clogging.

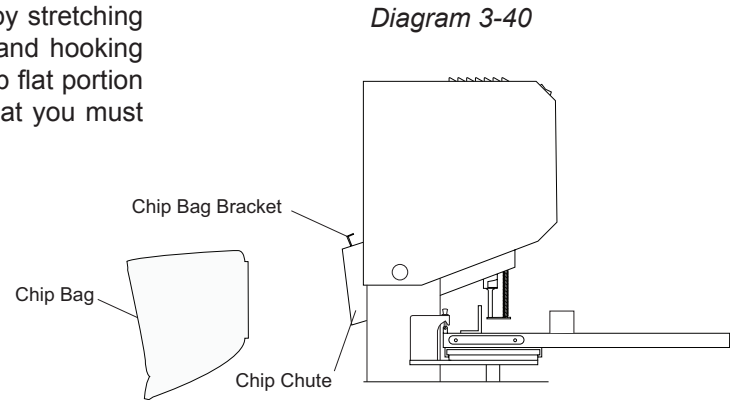



## 3 - Setting Up Your Machine

### 3.7 - Choosing and Installing the Pattern Bar

- 3.7.1** Your FM-2.1 comes with five pattern bars included: four (4) common patterns and one blank pattern as shown in diagram 3-100. Choose the pattern bar that lines up with your desired pattern.

Diagram 3-100



- 3.7.2** Insert a Pattern Bar by loosening the Pattern Bar Stop (EZ-1022) and inserting the desired pattern into the slot on the Pattern Bar Guide as shown in diagram 3-50. Insert the angled end into the slot as far as it will go so that the slot at the end of the Pattern Bar lines up with the Pattern Bar Stop. When you have the pattern correctly inserted, tighten down the Pattern Bar Stop through the slot on the Pattern Bar locking it in place.

Diagram 3-50

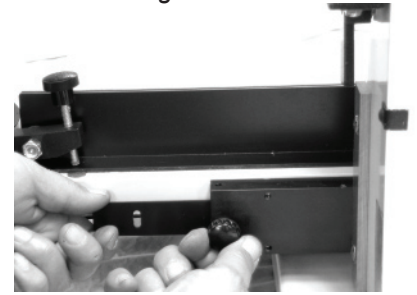

### 3.8 - Electrical Instructions

- 3.8.1** Your FM-2 comes with an electrical cord containing the plug to fit into a standard grounded 115V outlet. This machine has a full load draw of 5 Amps.

- 3.8.2** Making sure that nothing is interfering with the drill bits, plug the cord set into a grounded 115V outlet. To turn the machine on, press the Rocker Switch on the front of the shroud.

Diagram 3-60

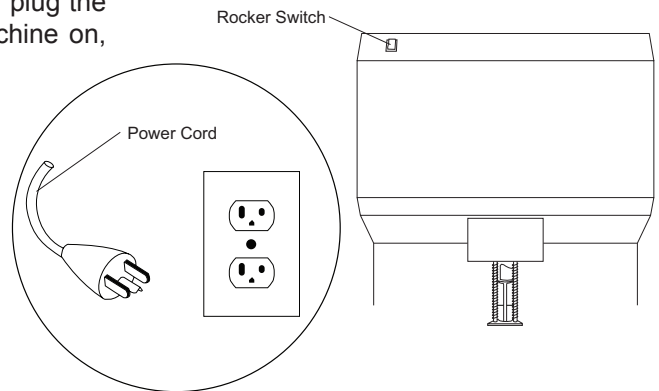

# 4 - Operation

## 4.1 - Protective Guard

- 4.1.1** Your FM-2 comes with a protective guard installed. DO NOT operate this machine without the guard in place.
- 4.1.2** Please note that when you are performing certain operations such as removing and installing drill bits, you will need to move the guard out of the way. Making sure the power to the machine is disconnected or locked-out, push the guard up and hold in place while performing necessary operations or maintenance. The protective guard should not be removed during operation.

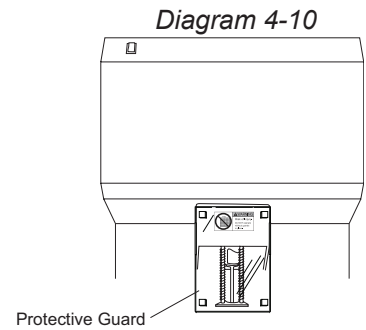

## 4.2 - Drill Bit Removal and Installation



**CAUTION: DRILL BITS MAY BE HOT AFTER USE. ALLOW DRILL BITS TO COOL DOWN BEFORE TOUCHING.**



**BEFORE REMOVING OR INSTALLING THE DRILL BITS, DISCONNECT OR LOCK-OUT THE POWER SUPPLY.**

- 4.2.1** Remove the hole guard which is attached to the chuck. This is done by grasping the tab and sliding the guard off.
- 4.2.2** Using the Chuck Release Key (EBM-32), insert the tapered end facing down into the chuck hole. With a clockwise motion turn the Chuck Release Key 45 degrees. The drill bit will slide out of the spindle. It is recommended that you hold onto the drill bit so that it does not drop out of the spindle damaging the tip. Place the hole guard back onto the chuck to protect debris from clogging the spindle.

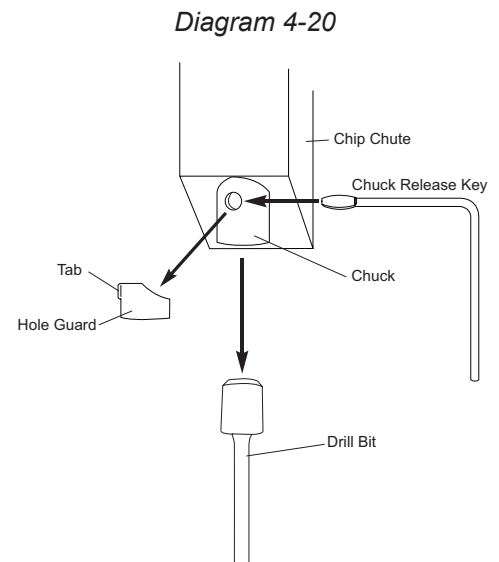

- 4.2.3** To install a drill bit, grasp the drill bit and being careful to keep it straight, press it up into the Chuck.
- 4.2.4** Seat the drill bit by using a stack of scrap paper. Set the scrap on the table as shown. Step on the foot pedal slowly raising the table toward the drill bit. Put light pressure on the hollow drill bit seating it firmly in place.
- 4.2.5** Remove the scrap paper and turn the machine on to check the concentricity of the bit. If the bit is not concentric, remove it and repeat steps 4.2.1 through 4.2.4 until it is concentric.

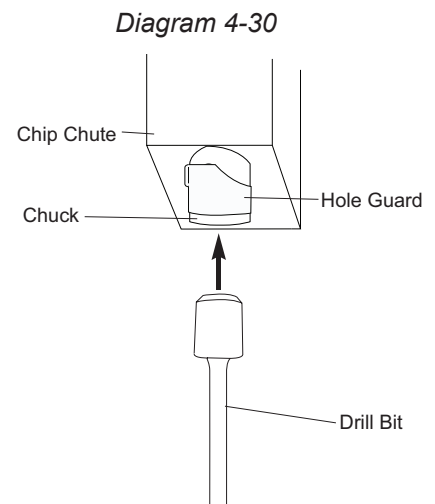

## 4 - Operation

### 4.3 - Adjusting the Table Height

**4.3.1** After you level the drill bit you may need to adjust your table height. Test drill through a stack of scrap approximately the same height as that you will be drilling. If the drill bit drills into the Drill Strip or if the drill bit fails to penetrate through the bottom sheet of scrap you will need to adjust the table height. If you are using the card stock under your scrap (recommended) then you should just be lightly scoring the card stock when the table is in its full upright position. If your bits are drilling correctly move onto section 4.4.

**4.3.2** If your drill bit fails to penetrate through the scrap: Loosen the Lock Knob of the Vertical Stop Adjustment Assembly and rotate the large knob counterclockwise allowing the table to travel higher. Tighten down the Lock Knob when it is positioned correctly.

**4.3.3** If you are drilling into the Drill Strip: Loosen the Lock Knob of the Vertical Stop Adjustment Assembly and rotate the large knob clockwise allowing the table to travel lower. Tighten down the Lock Knob when it is positioned correctly.

Diagram 4-40

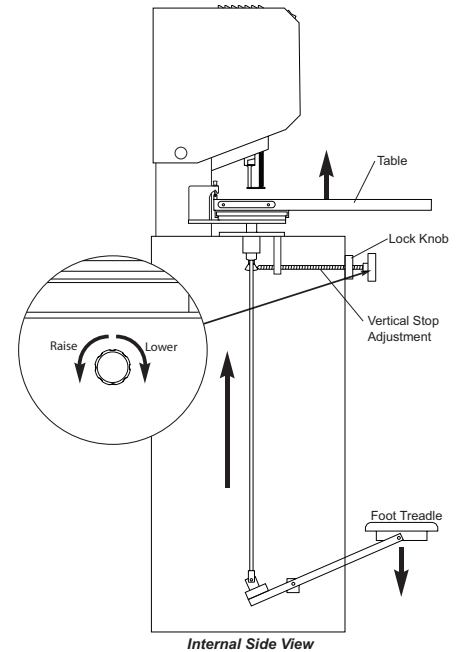

### 4.4 - Adjusting the Back-Gauge Assembly

**4.4.1** Adjust the Back-gauge so that it is the correct distance from the edge of the product to the center of the hole to be drilled by performing the following:

**4.4.2** Loosen the Clamp Knob on the right side of the Back-gauge.

**4.4.3** Using the two (2) Scales embedded in the rear corners of the table, align the front edge of the Back-gauge with the desired distance.

**4.4.4** Zero (0) on these scales align with the center of the hollow drill bits.

**4.4.5** Tighten down the Clamp Knob when the Back-gauge is positioned as desired.

Diagram 4-50

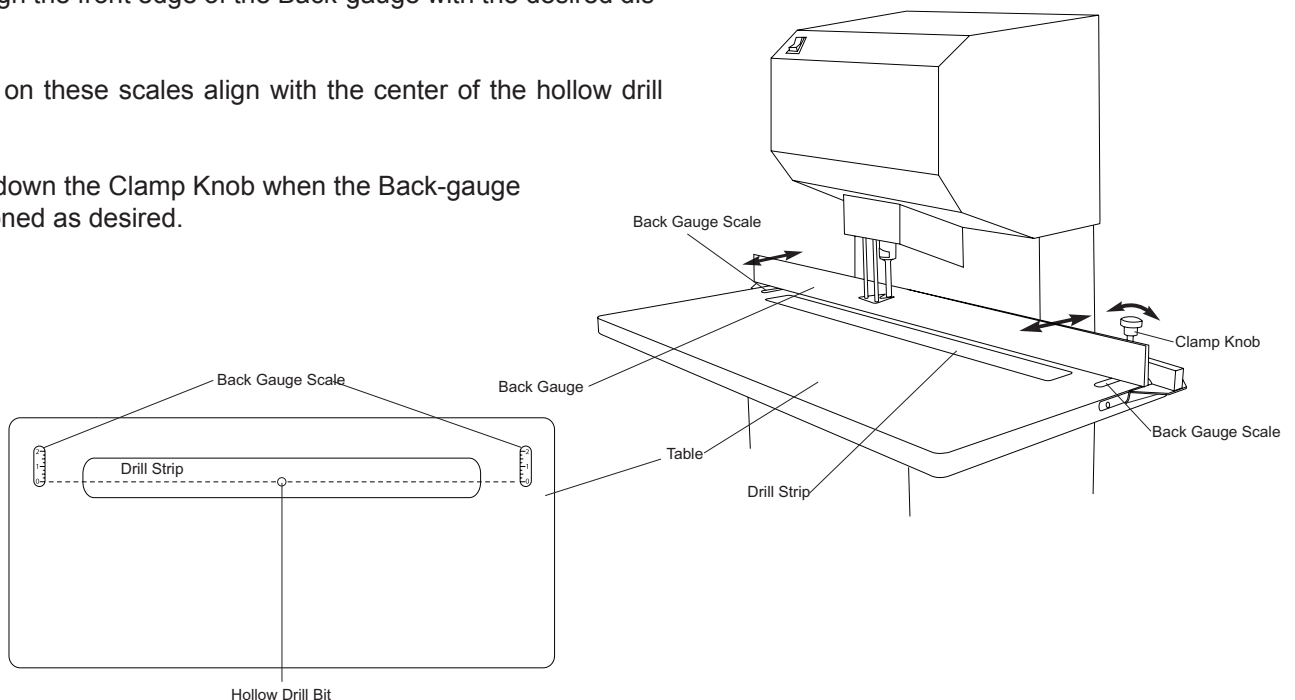

## 4 - Operation

### 4.5 - Traversing the Table

- 4.5.1** To move the Table to the next desired hole on the pattern bar, press in on either of the Release Handles (EZ-1010) located on both ends of the table. Pressing in the Release Handle releases the Release Pin allowing the table to traverse. Release the Handle and slide the Table until it locks into place in the next desired position.

*Diagram 4-60*

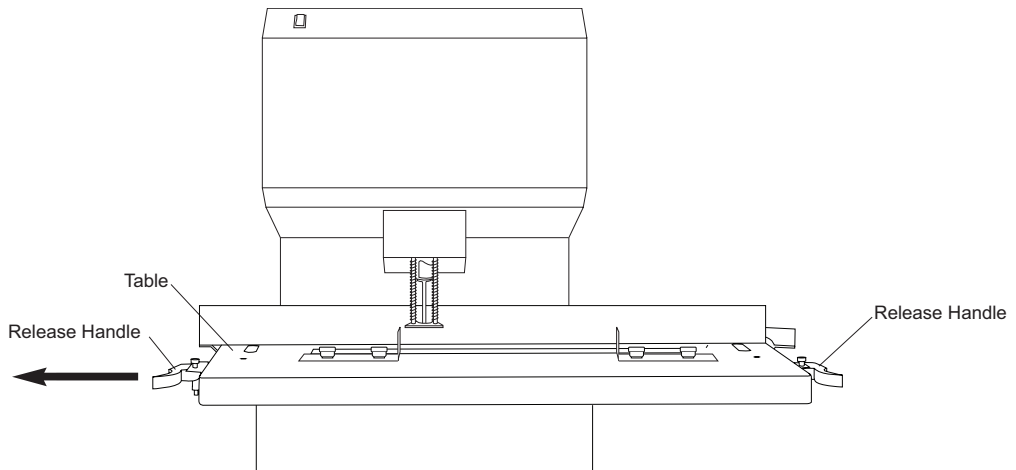

## 4 - Operation

### 4.6 - Drilling Procedures

**4.6.1** After all your adjustments are made as desired, position the Table in its original position. Set the product to be drilled on the table and make sure it is secure using the Paper Side Stops. To drill, step down on the Foot Treadle raising the Table up to meet the drill bit. Using one consistent smooth stroke, put pressure on the Treadle so that the Table rises fully allowing the drill bits to drill through the product. It is important you maintain a consistent speed through the entire stack. It is also important you do not go too slow or too fast. If you drill too slow you can burn the paper leaving undesired marks. If you drill too fast, the drill bit will act more like a punch and they will break.

**4.6.2** Different product requires different speeds. It is always recommended to drill through a test stack of the product until the operator is confident of the required speed.

Diagram 4-110

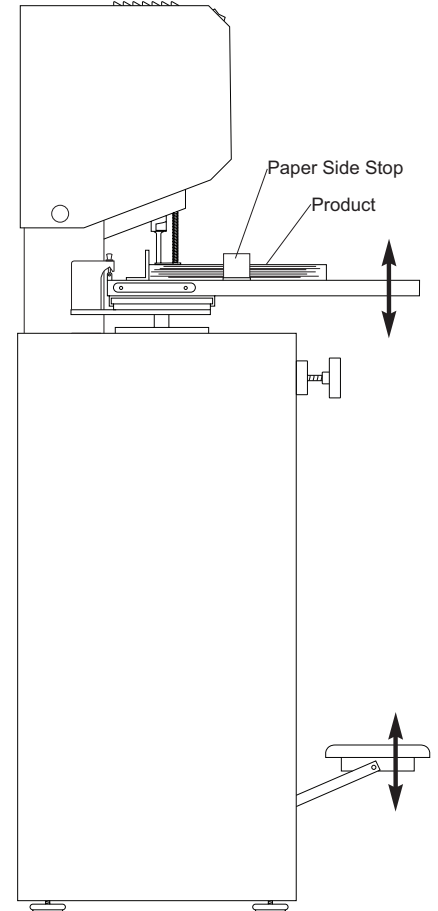

### 4.7 - Tips on Drilling

- 4.7.1** Use a sharp drill bit at all times... Using the MS-1 drill bit sharpener, sharpen your drill bits regularly. Apply light pressure when sharpening. Too much pressure may cause flaring of the tip. (Once a drill bit has a flared tip, it becomes defective.)
- 4.7.2** Sharpening Stone... Use to debur the outside cutting edge of the drill bits for better performance.
- 4.7.3** Lubricate drill bits occasionally... Use Drill-Ease or Spin-Eze. While the drill is running, simply touch the Drill-Ease stick to the drill bit or brush on the Spin-Eze. Drill through scrap to remove any excess. This will allow for a smoother cut.
- 4.7.4** Drill Strips...When drilling, a drill bit must stop slightly above the drill strip. Replace worn out drill strips regularly to ensure proper drilling.

# 5 - Maintenance

## 5.1 - Safety



**ALWAYS DISCONNECT THE POWER BEFORE PERFORMING MAINTENANCE ON THIS MACHINE. MAINTENANCE SHOULD ONLY BE PERFORMED BY A QUALIFIED TECHNICIAN.**



**KEEP HANDS CLEAR WHILE PERFORMING MAINTENANCE ON THIS MACHINE. MOVING PARTS CAN CRUSH AND CUT.**

## 5.2 - Annual Lubrication

**5.2.1** Lubricate the pivot points, shown in the diagram 5-10, in the lower back portion of the machine with light machine oil. Lubricate the Treadle Pivot Assembly at the front of the machine in the same manner.

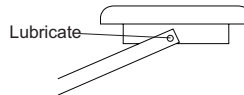
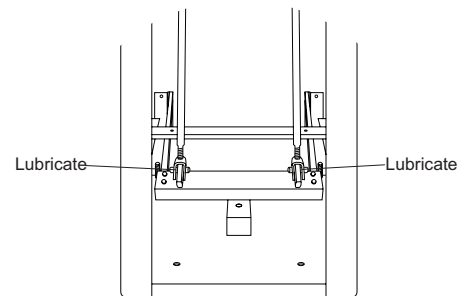

Diagram 5-10



**5.2.2** Press down on the Foot Treadle to Raise the Table. Manually holding the Table in place, slowly let up on the Foot Treadle so that the Push Rods in the rear of the machine fall out of the Pin Housings.

Lubricate the tips of the Push Rods and while holding up the Table return the Push Rods into the Pin Housings. Release the Table so that the Push Rods are locked in place.

Push down on the Foot Treadle to check for freedom of Travel.

Diagram 5-10

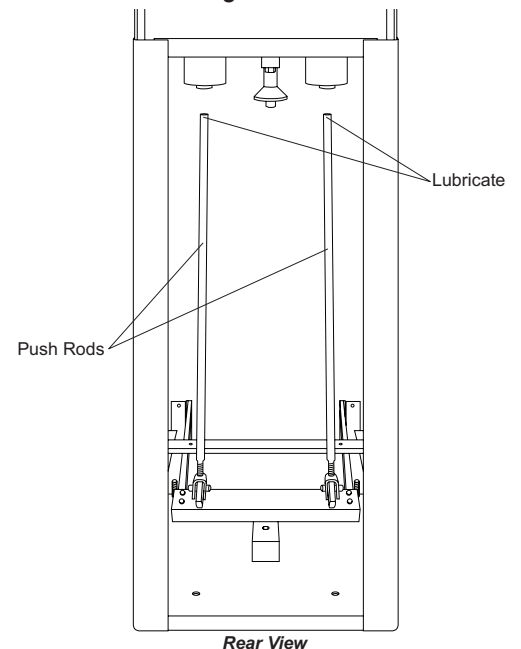

Lubricate

Push Rods

Rear View

## 6 - Trouble Shooting Guide

### 6.1 - Determining the Cause and Correction to Certain Problems

Problem	Cause	Correction
Drill bit not concentric.	Foreign material in chuck or in drill plug.	Inspect and clean.
	Drill bit is bent.	Replace drill bit.
	Drill bit not seated in chuck properly.	Re-insert drill bit correctly. (See <i>Operating Instructions</i> )
	Chuck is not tight to spindle.	Tighten set screw.
Drill bit not drilling.	Drill bit plugged.	Remove and clear chips. Check for other foreign matter.
	Drill bit dull.	Sharpen drill bit.
	<b>Note:</b> In extreme conditions, the drill chuck and/or chip chute may be plugged. Remove the drill bit, loosen the chip chute, pull down, and clean. See <i>Operating Instructions</i>	
Traverse table drags during operation.	Roller(s) or Roller Bearing(s) is/are damaged or worn.	Replace the Roller(s) and Roller Bearing(s) as needed.
	The Table is damaged.	Repair or replace the Table.
	<b>Note:</b> In order to maintain smooth table operation, <b>DO NOT</b> sit on, lean on, or force the table out of alignment. <b>DO NOT</b> lift the table or move the machine while holding onto the table as this can damage the Roller Bearings.	
Table lift system lifts unevenly or is noisy.	Loose or missing pivot components in the Treadle Pivot Assembly.	Tighten or replace as necessary.
	Push Rods out of adjustment.	Adjust Push Rods to lift evenly.
	Bushings in the lift system are dry or worn.	Lubricate or replace.
	Push Rods are bent.	Replace
	<b>Note:</b> If the raising mechanism is lifted without depressing the Foot Treadle, the Push Rods will drop out of position and must be re-installed in the Pushpins in order to operate the Table.	

## 6 - Trouble Shooting Guide

### 6.1 - Determining the Cause and Correction to Certain Problems

<b>Problem</b>	<b>Cause</b>	<b>Correction</b>
Machine vibrates, wobbles, resonates, etc.	The machine is not level on the floor.	Use the leveling feet to make the machine level on the floor. See <i>Setting Up Your Machine</i> .
	The machine is located directly on a concrete floor.	Place a rubber mat or carpet under the machine.
	Drill bit is not concentric.	Re-install drill bit until it is concentric. See <i>Operating Instructions</i> .
The drill bit is drilling into the drill strip or it is not drilling through the bottom sheet of the product you are drilling.	Drill bit was not adjusted properly to the card stock/card stock not used.	Adjust your drill bit per the <i>Operating Instructions</i> .
	The Table Travel Stop is out of adjustment.	Adjust to the proper Table Travel. See <i>Operating Instructions</i> .